

Features

- Operating voltage: 2.0V~6.0V
- Operating current < 2mA at 3.0V, No load
- Standby current $I_{VDD} < 2\mu A$, no load
- Separate logic power supply and motor power supply
- Built-in thermal shutdown circuit
- Built-in H bridge control circuit
- Built-in spark killer diode
- Provides strong ESD (min. of 4KV) per pin
- 8-pin SOP package

Applications

- Camera motor driver
- Toy motor driver

General Description

The IC can control H Bridge circuit for motor driving. It provides Spark Killer Diode/Thermal Shutdown function/Forward function/Reverse function/Brake func-

tion/Stop function for motor driver application. It is designed by LSI high technology with low power process.

Block Diagram

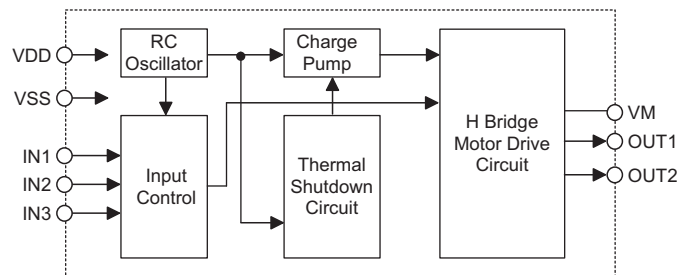

Pin Assignment

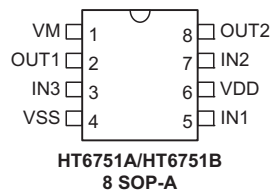

Pin Description

Pin No.	Pin Name	I/O	Description
1	VM	P	Power of motor driving circuit
2	OUT1	O	Connect to motor terminal
3	IN3	I	Input signal
4	VSS	—	Negative power supply, ground
5	IN1	I	Input signal
6	VDD	—	Positive power supply
7	IN2	I	Input signal
8	OUT2	O	Connect to motor terminal

Absolute Maximum Ratings

Supply Voltage.....	V_{DD} -0.3V to 7.0V	Storage Temperature.....	-40°C to 125°C
Voltage to Input Terminal.....	-0.3V to V_{DD} +0.3	Operating Temperature.....	-20°C to 85°C
Junction Temperature.....	150°C		

Note: These are stress ratings only. Stresses exceeding the range specified under "Absolute Maximum Ratings" may cause substantial damage to the device. Functional operation of this device at other conditions beyond those listed in the specification is not implied and prolonged exposure to extreme conditions may affect device reliability.

Electrical Characteristics
 $T_a=25^\circ\text{C}$

Symbol	Parameter	Test Conditions		Min.	Typ.	Max.	Unit
		V_{DD}	Conditions				
V_{DD}	Operating Voltage 1	—	—	2.0	—	6.0	V
V_M	Operating Voltage 2	—	Motor loading	1.8	—	6.0	V
I_{VM}	V_M Current	5V	Standby mode with internal pump	—	—	10	μA
I_{OPR}	Operating Current	5V	No load @ $V_{DD}=5\text{V}$	—	—	2	mA
I_{VDD}	Standby Current	5V	Standby mode	—	1	2	μA
I_{IL}	Input Leakage Current	5V	$0 < V_{in} < V_{DD}$	-1.0	—	1.0	μA
V_{IL}	Input Low Voltage	5V	—	-0.3	—	$0.3V_{DD}$	V
V_{IH}	Input High Voltage	5V	—	$0.6V_{DD}$	—	$V_{DD}+0.3$	V
R_{ON}	H Bridge On Resistance	3V	(up_NMOS+down_NMOS) at 3V	—	—	0.4	Ω
t_{CP_ON}	Charge Pump Turn On Time	5V	$V_{DD}=V_M=5\text{V}$, $I_{vm}=0.5\text{A}$	—	—	2	ms
t_{CP_OFF}	Charge Pump Turn Off Time	5V	$V_{DD}=V_M=5\text{V}$, $I_{vm}=0.5\text{A}$	—	—	1	ms
t_{H_ON}	H Bridge Turn On Time	5V	$V_{DD}=V_M=5\text{V}$, $I_{vm}=0.5\text{A}$	—	—	10	μs
t_{H_OFF}	H Bridge Turn Off Time	5V	$V_{DD}=V_M=5\text{V}$, $I_{vm}=0.5\text{A}$	—	—	5	μs

Functional Description

- In HT6751A function

IN1	IN2	IN3	Function	MOS On	MOS Off
0	1	1	Motor1 forward	P1/N2	P2/N1
1	0	1	Motor1 reverse	P2/N1	P1/N2
0	0	1	Motor1 brake	N1/N2	P1/P2
1	1	1	Standby mode	—	P1/P2/N1/N2
0	1	0	Motor2 forward	P2/(N3)	N2/(P3)
1	0	0	Motor2 reverse	N2/(P3)	P2/(N3)
0	0	0	Motor2 brake	N2/(N3)	P2/(P3)

- In HT6751B function

IN1	IN2	IN3	Function	MOS On	Mos Off
1	0	0	Motor1 forward	P1/N2	P2/N1
0	1	0	Motor1 reverse	P2/N1	P1/N2
1	1	0	Motor1 brake	N1/N2	P1/P2
0	0	0	Standby mode	—	P1/P2/N1/N2
1	0	1	Motor2 forward	P2/(N3)	N2/(P3)
0	1	1	Motor2 reverse	N2/(P3)	P2/(N3)
1	1	1	Motor2 brake	N2/(N3)	P2/(P3)

- ◆ In normal state and standby mode
 - Charge pump circuit is in off state
 - Oscillator circuit is in off state
 - Standby current is below 2μA
 - For HT6751A, the oscillator circuit and charge pump circuit is on until IN1 or IN2 or IN3 is low input
 - For HT6751B, the oscillator circuit and charge pump circuit is on until IN1 or IN2 or IN3 is high input
- ◆ The system enters thermal shutdown mode (current is limited below 500mA) when the temperature of the internal sensor is greater than Junction Temperature and then release this mode until the temperature of the internal sensor below (Junction Temperature >150°C). The system can accept IN1/IN2/IN3 signal when in thermal shutdown mode.

Application Circuits

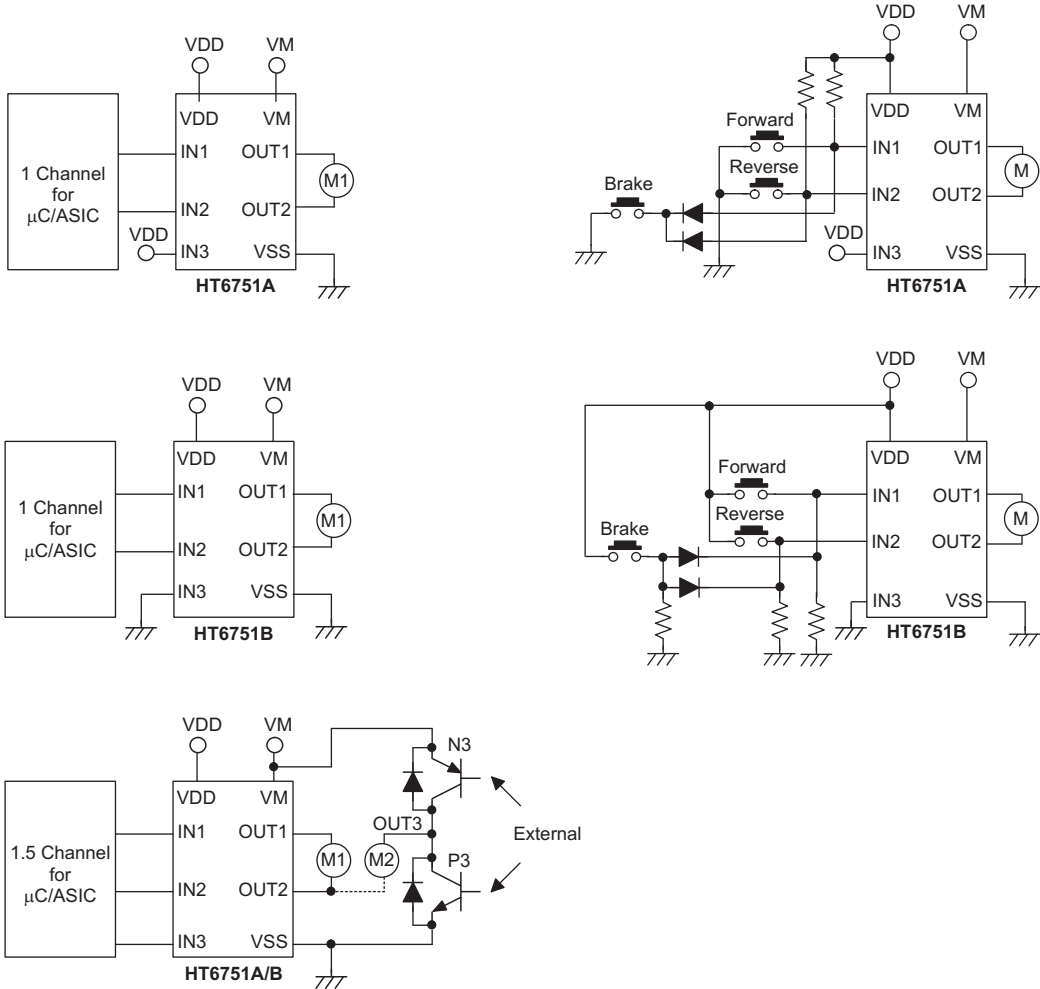

Package Information

Note that the package information provided here is for consultation purposes only. As this information may be updated at regular intervals users are reminded to consult the [Holtek website](#) for the latest version of the [package information](#).

Additional supplementary information with regard to packaging is listed below. Click on the relevant section to be transferred to the relevant website page.

- [Further Package Information \(include Outline Dimensions, Product Tape and Reel Specifications\)](#)
- [Packing Materials Information](#)
- [Carton Information](#)

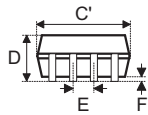
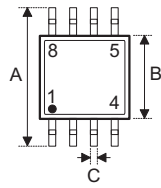
8-pin SOP (150mil) Outline Dimensions

Symbol	Dimensions in inch		
	Min.	Nom.	Max.
A	—	0.236 BSC	—
B	—	0.154 BSC	—
C	0.012	—	0.020
C'	—	0.193 BSC	—
D	—	—	0.069
E	—	0.050 BSC	—
F	0.004	—	0.010
G	0.016	—	0.050
H	0.004	—	0.010
α	0°	—	8°

Symbol	Dimensions in mm		
	Min.	Nom.	Max.
A	—	6.00 BSC	—
B	—	3.90 BSC	—
C	0.31	—	0.51
C'	—	4.90 BSC	—
D	—	—	1.75
E	—	1.27 BSC	—
F	0.10	—	0.25
G	0.40	—	1.27
H	0.10	—	0.25
α	0°	—	8°

Copyright © 2018 by HOLTEK SEMICONDUCTOR INC.

The information appearing in this Data Sheet is believed to be accurate at the time of publication. However, Holtek assumes no responsibility arising from the use of the specifications described. The applications mentioned herein are used solely for the purpose of illustration and Holtek makes no warranty or representation that such applications will be suitable without further modification, nor recommends the use of its products for application that may present a risk to human life due to malfunction or otherwise. Holtek's products are not authorized for use as critical components in life support devices or systems. Holtek reserves the right to alter its products without prior notification. For the most up-to-date information, please visit our web site at <http://www.holtek.com.tw>.