



Enhanced Touch A/D Flash MCU with LED Driver

BS86C08C/BS86D12C

BS86E16C/BS86D20C

Revision: V1.40 Date: September 23, 2022

www.holtek.com

Table of Contents

Features	7
CPU Features	7
Peripheral Features.....	7
General Description	8
Selection Table	8
Block Diagram	9
Pin Assignment	9
Pin Descriptions	13
Absolute Maximum Ratings	23
D.C. Electrical Characteristics	23
Operating Voltage Characteristics.....	23
Operating Current Characteristics.....	24
Standby Current Characteristics	25
A.C. Characteristics	26
High Speed Internal Oscillator – HIRC – Frequency Accuracy	26
Low Speed Oscillators Characteristics – LIRC & LXT	26
Operating Frequency Characteristic Curves	27
System Start Up Time Characteristics	27
Input/Output Characteristics	28
Memory Characteristics	29
LVD/LVR Electrical Characteristics	29
A/D Converter Electrical Characteristics	30
Internal Reference Voltage Characteristics	30
Power-on Reset Characteristics	30
System Architecture	31
Clocking and Pipelining.....	31
Program Counter.....	32
Stack	32
Arithmetic and Logic Unit – ALU	33
Flash Program Memory	34
Structure.....	34
Special Vectors	34
Look-up Table.....	34
Table Program Example	35
In Circuit Programming – ICP	36
On-Chip Debug Support – OCDS	37
Data Memory	38
Structure	38
Data Memory Addressing.....	39

General Purpose Data Memory	39
Special Purpose Data Memory	39
Special Function Register Description.....	44
Indirect Addressing Registers – IAR0, IAR1, IAR2	44
Memory Pointers – MP0, MP1L, MP1H, MP2L, MP2H.....	44
Program Memory Bank Pointer – PBP.....	45
Accumulator – ACC	46
Program Counter Low Register – PCL	46
Look-up Table Registers – TBLP, TBHP, TBLH	46
Status Register – STATUS	46
EEPROM Data Memory.....	48
EEPROM Data Memory Structure	48
EEPROM Registers	48
Reading Data from the EEPROM	50
Writing Data to the EEPROM.....	50
Write Protection.....	51
EEPROM Interrupt	51
Programming Considerations.....	51
Oscillators	52
Oscillator Overview	52
System Clock Configurations.....	52
Internal High Speed RC Oscillator – HIRC	53
Internal 32kHz Oscillator – LIRC.....	53
External 32.768kHz Crystal Oscillator – LXT (BS86E16C/BS86D20C).....	54
Operating Modes and System Clocks	55
System Clocks	55
System Operation Modes.....	56
Control Registers	57
Operating Mode Switching.....	60
Standby Current Considerations	62
Wake-up.....	63
Programming Considerations.....	63
Watchdog Timer.....	64
Watchdog Timer Clock Source.....	64
Watchdog Timer Control Register	64
Watchdog Timer Operation	65
Reset and Initialisation.....	66
Reset Functions	66
Reset Initial Conditions	69
Input/Output Ports	74
Pull-high Resistors	75
Port A Wake-up	75
I/O Port Control Registers	76

I/O Port Source Current Selection.....	76
I/O Port Sink Current Selection	79
I/O Port Power Source Control – BS86E16C Only	83
Pin-remapping Function	83
I/O Pin Structures.....	88
Programming Considerations.....	88
Timer Modules – TM	89
Introduction	89
TM Operation	89
TM Clock Source.....	89
TM Interrupts.....	90
TM External Pins.....	90
TM Input/Output Pin Control Register	90
Programming Considerations.....	94
Compact Type TM – CTM	96
Compact Type TM Operation	96
Compact Type TM Register Description.....	96
Compact Type TM Operation Modes	101
Periodic Type TM – PTM.....	107
Periodic TM Operation	107
Periodic Type TM Register Description.....	107
Periodic Type TM Operation Modes.....	112
Analog to Digital Converter	121
A/D Overview	121
A/D Converter Register Description	121
A/D Converter Reference Voltage.....	125
A/D Converter Input Signals.....	125
A/D Converter Operation.....	126
Conversion Rate and Timing Diagram	127
Summary of A/D Conversion Steps.....	128
Programming Considerations.....	129
A/D Transfer Function	129
A/D Programming Examples.....	129
Touch Key Function	131
Touch Key Structure.....	131
Touch Key Register Definition	131
Touch Key Operation.....	136
Touch Key Interrupt.....	137
Programming Considerations.....	137
I²C Interface – BS86C08C/BS86D12C/BS86E16C.....	138
I ² C Interface Operation.....	138
I ² C Registers	139
I ² C Bus Communication	142
I ² C Time-out Control.....	145

Serial Interface Module – SIM – BS86D20C	146
SPI Interface	146
I ² C Interface	154
UART Interfaces	163
UARTn External Pins	164
UARTn Data Transfer Scheme	164
UARTn Status and Control Registers	164
Baud Rate Generator	170
UARTn Setup and Control	170
UARTn Transmitter	172
UARTn Receiver	173
Managing Receiver Errors	174
UARTn Interrupt Structure	175
UARTn Power Down and Wake-up	176
Low Voltage Detector – LVD	177
LVD Register	177
LVD Operation	178
Interrupts	179
Interrupt Registers	181
Interrupt Operation	187
External Interrupt	188
Touch Key Module Interrupt	188
Time Base Interrupts	188
I ² C Interrupt – BS86C08C/BS86D12C/BS86E16C	191
Serial Interface Module Interrupt – BS86D20C	191
EEPROM Interrupt	191
UART Transfer Interrupts	191
LVD Interrupt	192
A/D Converter Interrupt	192
Multi-function Interrupt – BS86E16C/BS86D20C	192
TM Interrupts	192
Interrupt Wake-up Function	193
Programming Considerations	193
Configuration Options	194
Application Circuits	194
Instruction Set	195
Introduction	195
Instruction Timing	195
Moving and Transferring Data	195
Arithmetic Operations	195
Logical and Rotate Operation	196
Branches and Control Transfer	196
Bit Operations	196
Table Read Operations	196

Other Operations.....	196
Instruction Set Summary	197
Table Conventions.....	197
Extended Instruction Set.....	199
Instruction Definition.....	201
Extended Instruction Definition	210
Package Information	217
24-pin SOP (300mil) Outline Dimensions	218
24-pin SSOP (150mil) Outline Dimensions	219
28-pin SOP (300mil) Outline Dimensions	220
28-pin SSOP (150mil) Outline Dimensions	221
44-pin LQFP (10mm×10mm) (FP2.0mm) Outline Dimensions	222

Features

CPU Features

- Operating Voltage:
 - ♦ $f_{SYS}=8\text{MHz}$: 2.2V~5.5V
 - ♦ $f_{SYS}=12\text{MHz}$: 2.7V~5.5V
 - ♦ $f_{SYS}=16\text{MHz}$: 3.3V~5.5V
- Up to 0.25 μs instruction cycle with 16MHz system clock at $V_{DD}=5\text{V}$
- Power down and wake-up functions to reduce power consumption
- Oscillator types:
 - ♦ Internal High Speed 8/12/16MHz RC – HIRC
 - ♦ Internal Low Speed 32kHz RC – LIRC
 - ♦ External Low Speed 32.768kHz Crystal – LXT, for BS86E16C/BS86D20C
- Multi-mode operation: FAST, SLOW, IDLE and SLEEP
- Fully integrated internal oscillators require no external components
- All instructions executed in 1~3 instruction cycles
- Table read instructions
- 115 powerful instructions
- 8-level subroutine nesting
- Bit manipulation instruction

Peripheral Features

- Flash Program Memory: 4K \times 16~16K \times 16
- Data Memory: 384 \times 8~768 \times 8
- True EEPROM Memory: 32 \times 8~64 \times 8
- Up to 20 touch key functions – fully integrated without requiring external components
- Watchdog Timer function
- Up to 42 bidirectional I/O lines
- Programmable I/O port source current and sink current for LED driver
- Single external interrupt line shared with I/O pin
- Multiple Timer Modules for time measurement, input capture, compare match output or PWM output or single pulse output function
- Up to 2 Time-Base functions for generation of fixed time interrupt signals
- 8-external-channel 12-bit resolution A/D converter
- I²C interface (BS86C08C/BS86D12C/BS86E16C)
- Serial Interface Module – SIM includes SPI and I²C interfaces (BS86D20C only)
- Up to 2 fully-duplex Universal Asynchronous Receiver and Transmitter Interfaces – UART
- Low voltage reset function
- Low voltage detect function
- Wide range of available package types

General Description

The series of devices are Flash Memory type 8-bit high performance RISC architecture microcontrollers with fully integrated touch key functions. With all touch key functions provided internally and with the convenience of Flash Memory multi-programming features, each device has all the features to offer designers a reliable and easy means of implementing Touch Keys within their products applications.

The touch key functions are fully integrated completely eliminating the need for external components. In addition to the flash program memory, other memory includes an area of RAM Data Memory as well as an area of true EEPROM memory for storage of non-volatile data such as serial numbers, calibration data etc. Analog feature includes a multi-channel 12-bit A/D converter. Protective features such as an internal Watchdog Timer, Low Voltage Reset and Low Voltage Detector coupled with excellent noise immunity and ESD protection ensure that reliable operation is maintained in hostile electrical environments.

A full choice of external low, internal high and low speed oscillators are provided including fully integrated system oscillators which require no external components for its implementation. The ability to operate and switch dynamically between a range of operating modes using different clock sources gives users the ability to optimise microcontroller operation and minimise power consumption. Easy communication with the outside world is provided using the internal I²C, SPI and UART interfaces, while the inclusion of flexible I/O programming features, Time-Base functions, Timer Modules and many other features further enhance device functionality and flexibility.

The touch key devices will find excellent use in a huge range of modern Touch Key product applications such as sensor signal processing, home appliance, health care product, industrial control, consumer products, subsystem controllers to name but a few.

Selection Table

Most features are common to all devices and the main features distinguishing them are Memory capacity, I/O count, Touch key count, UART, LXT, Time Base, Timer Module number and package types. The following table summarises the main features of each device.

Part No.	Program Memory	Data Memory	Data EEPROM	I/O	External Interrupt	A/D	Time Base
BS86C08C	4K×16	384×8	32×8	26	1	12-bit×8	1
BS86D12C	8K×16	512×8	64×8	26	1	12-bit×8	1
BS86E16C	16K×16	768×8	64×8	42	1	12-bit×8	2
BS86D20C	8K×16	768×8	64×8	26	1	12-bit×8	2

Part No.	Timer Module	Touch Key	I ² C	SIM (SPI+I ² C)	UART	LXT	Stack	Package
BS86C08C	10-bit CTM×1 10-bit PTM×1	8	√	—	1	—	8	24SOP/SSOP 28SOP/SSOP
BS86D12C	10-bit CTM×1 10-bit PTM×1	12	√	—	1	—	8	24SOP/SSOP 28SOP/SSOP
BS86E16C	10-bit CTM×1 10-bit PTM×2	16	√	—	2	√	8	28SOP/SSOP 44LQFP
BS86D20C	10-bit CTM×1 10-bit PTM×2	20	—	√	1	√	8	24/28SOP

Note: As devices exist in more than one package format, the table reflects the situation for the package with the most pins.

Block Diagram

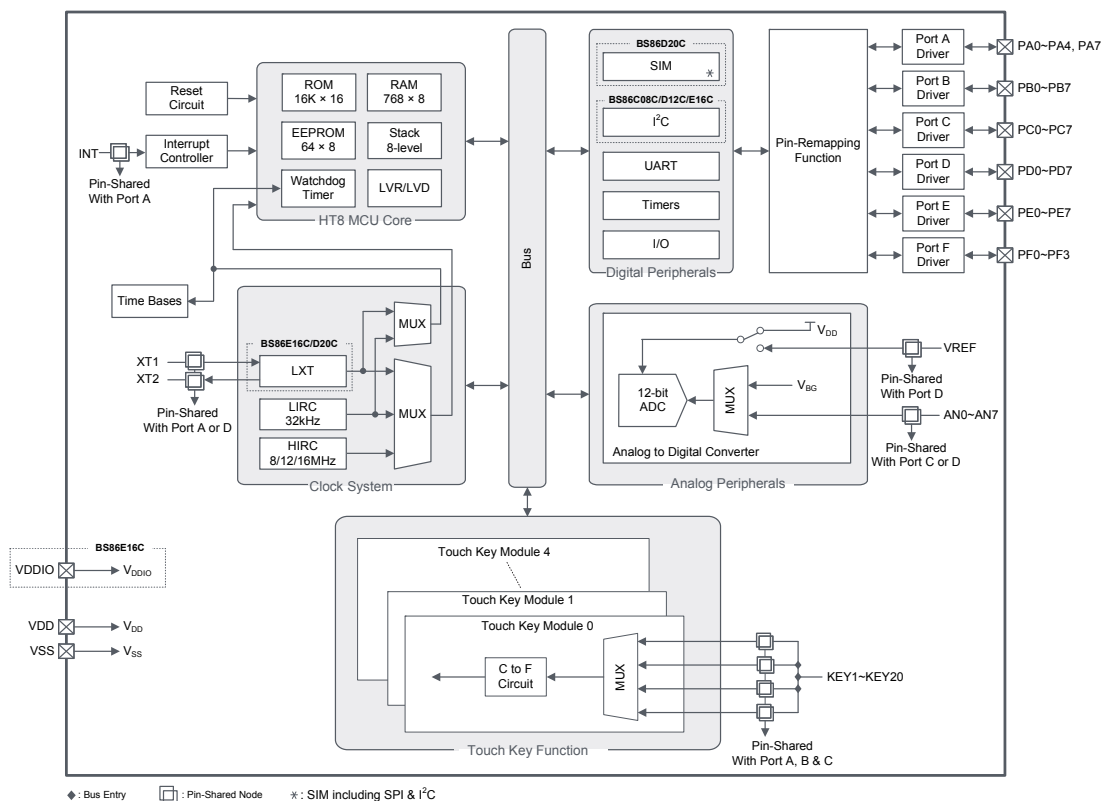

Pin Assignment

PB0/KEY1	1	24	PA7/PTCK0/CTCK0
PB1/KEY2	2	23	PA4/PTP0/CTP0/INT
PB2/KEY3	3	22	PA2/PTP0B/ICPCK/OCDSCK
PB3/KEY4	4	21	PA0/CTP0B/ICPDA/OCSDSA
PB4/KEY5	5	20	VDD
PB5/KEY6	6	19	PA3/[SDA]/TX0
PB6/KEY7	7	18	PA1/[SCL]/RX0
PB7/KEY8	8	17	VSS
PC0/[CTCK0]	9	16	PD5/PTP0/AN5
PC1/[CTP0]	10	15	PD4/AN4/VREF
PC2/[SCL]/[RX0]	11	14	PD3/AN3
PC3/[SDA]/[TX0]	12	13	PD2/AN2

BS86C08C/BS86CV08C
24 SOP-A/SSOP-A

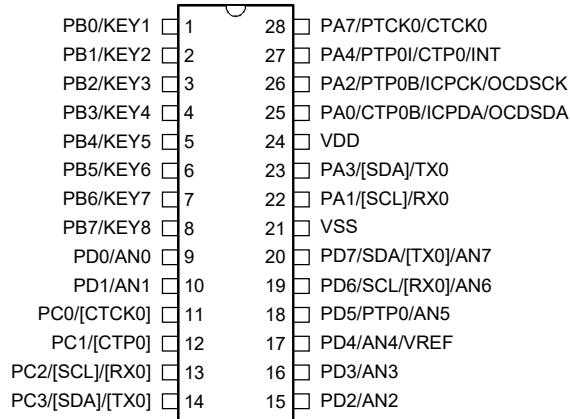

BS86C08C/BS86CV08C
28 SOP-A/SSOP-A

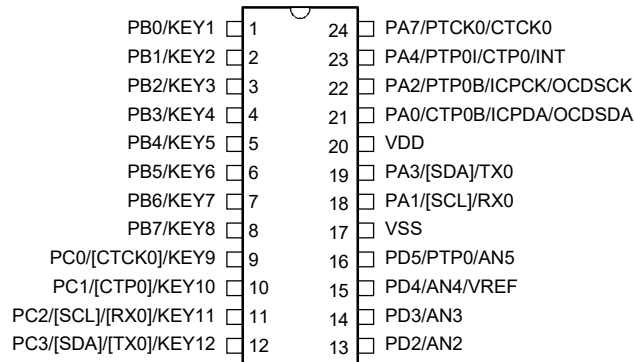

BS86D12C/BS86DV12C
24 SOP-A/SSOP-A

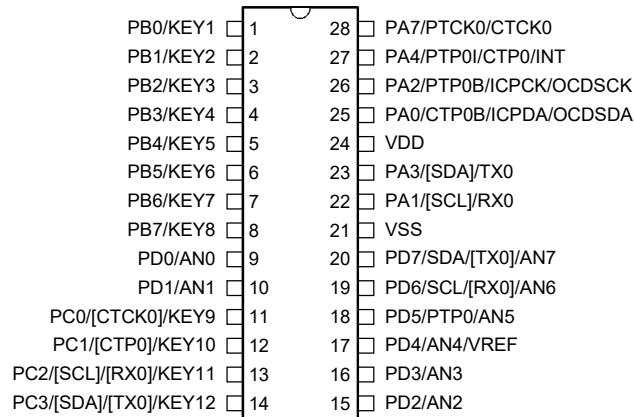

BS86D12C/BS86DV12C
28 SOP-A/SSOP-A

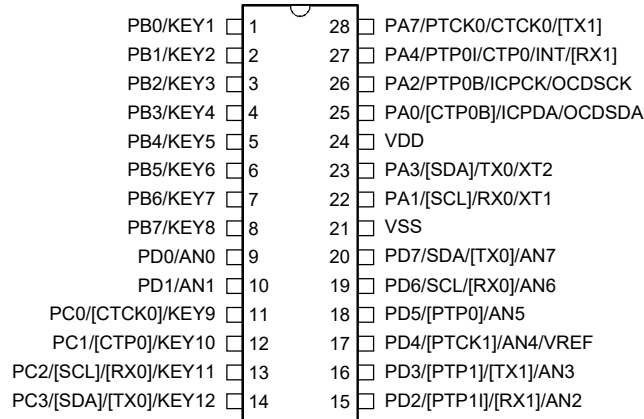

BS86E16C/BS86EV16C
28 SOP-A/SSOP-A

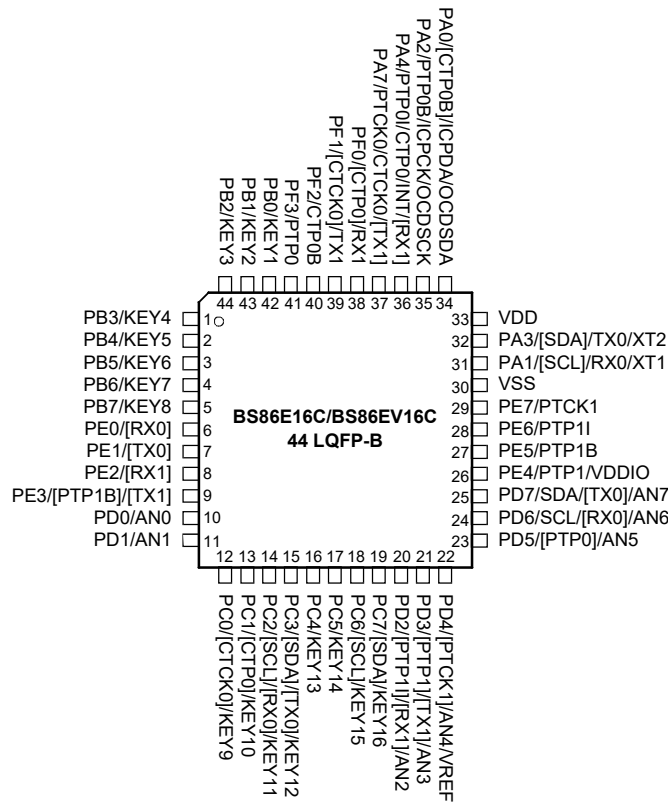

BS86E16C/BS86EV16C
44 LQFP-B

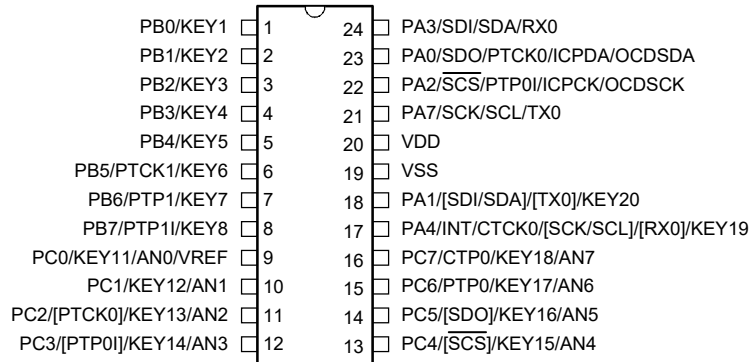

BS86D20C/BS86DV20C
24 SOP-A

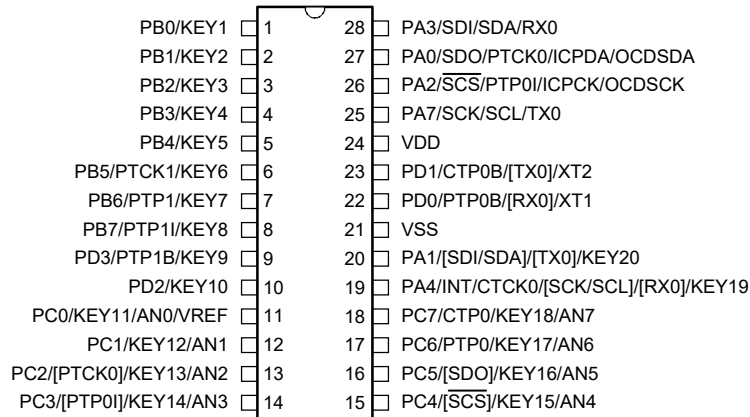

BS86D20C/BS86DV20C
28 SOP-A

- Note: 1. Bracketed pin names indicate non-default pinout remapping locations.
 2. If the pin-shared pin functions have multiple outputs simultaneously, its pin names at the right side of the “/” sign can be used for higher priority.
 3. The OCSDA and OCDSCK pins are supplied for the OCDS dedicated pins and as such only available for the BS86CV08C/BS86DV12C/BS86EV16C/BS86DV20C devices which are the OCDS EV chips for the BS86C08C/BS86D12C/BS86E16C/BS86D20C devices respectively.
 4. For less pin-count package types there will be unbonded pins which should be properly configured to avoid unwanted current consumption resulting from floating input conditions. Refer to the “Standby Current Considerations” and “Input/Output Ports” sections.

Pin Descriptions

With the exception of the power pins, all pins on the devices can be referenced by their Port name, e.g. PA0, PA1 etc., which refer to the digital I/O function of the pins. However these Port pins are also shared with other function such as the Touch Key function, Timer Module pins etc. The function of each pin is listed in the following table, however the details behind how each pin is configured is contained in other sections of the datasheet.

As the Pin Description table shows the situation for the package with the most pins, not all pins in the table will be available on smaller package sizes.

BS86C08C/BS86CV08C

Pin Name	Function	OPT	I/T	O/T	Description
PA0/CTP0B/ICPDA/OCSDA	PA0	PAPU PAWU	ST	CMOS	General purpose I/O. Register enabled pull-up and wake-up
	CTP0B	TMPC	—	CMOS	CTM0 inverted output
	ICPDA	—	ST	CMOS	ICP data/address pin
	OCSDA	—	ST	CMOS	OCDS data/address pin, for EV chip only.
PA1/[SCL]/RX0	PA1	PAPU PAWU	ST	CMOS	General purpose I/O. Register enabled pull-up and wake-up
	SCL	IICC0 IFS0	ST	NMOS	I ² C clock line
	RX0	U0CR1 IFS0 IFS2	ST	—	UART0 data receive pin
PA2/PTP0B/ICPCK/OCDSCK	PA2	PAPU PAWU	ST	CMOS	General purpose I/O. Register enabled pull-up and wake-up
	PTP0B	TMPC	—	CMOS	PTM0 inverted output
	ICPCK	—	ST	—	ICP clock pin
	OCDSCK	—	ST	—	OCDS clock pin, for EV chip only
PA3/[SDA]/TX0	PA3	PAPU PAWU	ST	CMOS	General purpose I/O. Register enabled pull-up and wake-up
	SDA	IICC0 IFS0	ST	NMOS	I ² C data line
	TX0	U0CR1 IFS0	—	CMOS	UART0 data transmit pin
PA4/PTP0I/CTP0/INT	PA4	PAPU PAWU	ST	CMOS	General purpose I/O. Register enabled pull-up and wake-up
	PTP0I	PTM0C0 PTM0C1	ST	—	PTM0 capture input
	CTP0	TMPC IFS1	—	CMOS	CTM0 output
	INT	INTC0 INTEG	ST	—	External interrupt input
PA7/PTCK0/CTCK0	PA7	PAPU PAWU	ST	CMOS	General purpose I/O. Register enabled pull-up and wake-up
	PTCK0	PTM0C0	ST	—	PTM0 clock input
	CTCK0	CTM0C0 IFS1	ST	—	CTM0 clock input
PB0/KEY1~PB3/KEY4	PB0~PB3	PBPU	ST	CMOS	General purpose I/O. Register enabled pull-up
	KEY1~KEY4	TKM0C1	NSI	—	Touch key input
PB4/KEY5~PB7/KEY8	PB4~PB7	PBPU	ST	CMOS	General purpose I/O. Register enabled pull-up
	KEY5~KEY8	TKM1C1	NSI	—	Touch key input

Pin Name	Function	OPT	I/T	O/T	Description
PC0/[CTCK0]	PC0	PCPU	ST	CMOS	General purpose I/O. Register enabled pull-up
	CTCK0	CTM0C0 IFS1	ST	—	CTM0 clock input
PC1/[CTP0]	PC1	PCPU	ST	CMOS	General purpose I/O. Register enabled pull-up
	CTP0	TMPC IFS1	—	CMOS	CTM0 output
PC2/[SCL]/[RX0]	PC2	PCPU	ST	CMOS	General purpose I/O. Register enabled pull-up
	SCL	IICC0 IFS0	ST	NMOS	I ² C clock line
	RX0	U0CR1 IFS0 IFS2	ST	—	UART0 data receive pin
PC3/[SDA]/[TX0]	PC3	PCPU	ST	CMOS	General purpose I/O. Register enabled pull-up
	SDA	IICC0 IFS0	ST	NMOS	I ² C data line
	TX0	U0CR1 IFS0	—	CMOS	UART0 data transmit pin
PD0/AN0	PD0	PDPU	ST	CMOS	General purpose I/O. Register enabled pull-up
	AN0	ACERL	AN	—	A/D Converter external input channel
PD1/AN1	PD1	PDPU	ST	CMOS	General purpose I/O. Register enabled pull-up
	AN1	ACERL	AN	—	A/D Converter external input channel
PD2/AN2	PD2	PDPU	ST	CMOS	General purpose I/O. Register enabled pull-up
	AN2	ACERL	AN	—	A/D Converter external input channel
PD3/AN3	PD3	PDPU	ST	CMOS	General purpose I/O. Register enabled pull-up
	AN3	ACERL	AN	—	A/D Converter external input channel
PD4/AN4/VREF	PD4	PDPU	ST	CMOS	General purpose I/O. Register enabled pull-up
	AN4	ACERL	AN	—	A/D Converter external input channel
	VREF	TMPC	AN	—	A/D Converter external reference voltage input
PD5/PTP0/AN5	PD5	PDPU	ST	CMOS	General purpose I/O. Register enabled pull-up
	PTP0	TMPC	—	CMOS	PTM0 output
	AN5	ACERL	AN	—	A/D Converter external input channel
PD6/SCL/[RX0]/AN6	PD6	PDPU	ST	CMOS	General purpose I/O. Register enabled pull-up
	SCL	IICC0 IFS0	ST	NMOS	I ² C clock line
	RX0	U0CR1 IFS0 IFS2	ST	—	UART0 data receive pin
	AN6	ACERL	AN	—	A/D Converter external input channel
PD7/SDA/[TX0]/AN7	PD7	PDPU	ST	CMOS	General purpose I/O. Register enabled pull-up
	SDA	IICC0 IFS0	ST	NMOS	I ² C data line
	TX0	U0CR1 IFS0	—	CMOS	UART0 data transmit pin
	AN7	ACERL	AN	—	A/D Converter external input channel
VDD	VDD	—	PWR	—	Positive power supply
VSS	VSS	—	PWR	—	Negative power supply, ground.

Legend: I/T: Input type; O/T: Output type;
 OPT: Optional by register selection;
 PWR: Power; ST: Schmitt Trigger input;
 CMOS: CMOS output; NMOS: NMOS output;
 AN: Analog signal; NSI: Non-standard input.

BS86D12C/BS86DV12C

Pin Name	Function	OPT	I/T	O/T	Description
PA0/CTP0B/ICPDA/ OCSDSA	PA0	PAPU PAWU	ST	CMOS	General purpose I/O. Register enabled pull-up and wake-up
	CTP0B	TMPC	—	CMOS	CTM0 inverted output
	ICPDA	—	ST	CMOS	ICP data/address pin
	OCSDSA	—	ST	CMOS	OCDS data/address pin, for EV chip only.
PA1/[SCL]/RX0	PA1	PAPU PAWU	ST	CMOS	General purpose I/O. Register enabled pull-up and wake-up
	SCL	IICC0 IFS0	ST	NMOS	I ² C clock line
	RX0	U0CR1 IFS0 IFS2	ST	—	UART0 data receive pin
PA2/PTP0B/ICPCK/ OCDSCK	PA2	PAPU PAWU	ST	CMOS	General purpose I/O. Register enabled pull-up and wake-up
	PTP0B	TMPC	—	CMOS	PTM0 inverted output
	ICPCK	—	ST	—	ICP clock pin
	OCDSCK	—	ST	—	OCDS clock pin, for EV chip only
PA3/[SDA]/TX0	PA3	PAPU PAWU	ST	CMOS	General purpose I/O. Register enabled pull-up and wake-up
	SDA	IICC0 IFS0	ST	NMOS	I ² C data line
	TX0	U0CR1 IFS0	—	CMOS	UART0 data transmit pin
PA4/PTP0I/CTP0/INT	PA4	PAPU PAWU	ST	CMOS	General purpose I/O. Register enabled pull-up and wake-up
	PTP0I	PTM0C0 PTM0C1	ST	—	PTM0 capture input
	CTP0	TMPC IFS1	—	CMOS	CTM0 output
	INT	INTC0 INTEG	ST	—	External interrupt input
PA7/PTCK0/CTCK0	PA7	PAPU PAWU	ST	CMOS	General purpose I/O. Register enabled pull-up and wake-up
	PTCK0	PTM0C0	ST	—	PTM0 clock input
	CTCK0	CTM0C0 IFS1	ST	—	CTM0 clock input
PB0/KEY1~PB3/KEY4	PB0~PB3	PBPU	ST	CMOS	General purpose I/O. Register enabled pull-up
	KEY1~KEY4	TKM0C1	NSI	—	Touch key input
PB4/KEY5~PB7/KEY8	PB4~PB7	PBPU	ST	CMOS	General purpose I/O. Register enabled pull-up
	KEY5~KEY8	TKM1C1	NSI	—	Touch key input
PC0/[CTCK0]/KEY9	PC0	PCPU	ST	CMOS	General purpose I/O. Register enabled pull-up
	CTCK0	CTM0C0 IFS1	ST	—	CTM0 clock input
	KEY9	TKM2C1	NSI	—	Touch key input
PC1/[CTP0]/KEY10	PC1	PCPU	ST	CMOS	General purpose I/O. Register enabled pull-up
	CTP0	TMPC IFS1	—	CMOS	CTM0 output
	KEY10	TKM2C1	NSI	—	Touch key input

Pin Name	Function	OPT	I/T	O/T	Description
PC2/[SCL]/[RX0]/KEY11	PC2	PCPU	ST	CMOS	General purpose I/O. Register enabled pull-up
	SCL	IICC0 IFS0	ST	NMOS	I ² C clock line
	RX0	U0CR1 IFS0 IFS2	ST	—	UART0 data receive pin
	KEY11	TKM2C1	NSI	—	Touch key input
PC3/[SDA]/[TX0]/KEY12	PC3	PCPU	ST	CMOS	General purpose I/O. Register enabled pull-up
	SDA	IICC0 IFS0	ST	NMOS	I ² C data line
	TX0	U0CR1 IFS0	—	CMOS	UART0 data transmit pin
	KEY12	TKM2C1	NSI	—	Touch key input
PD0/AN0	PD0	PDPUP	ST	CMOS	General purpose I/O. Register enabled pull-up
	AN0	ACERL	AN	—	A/D Converter external input channel
PD1/AN1	PD1	PDPUP	ST	CMOS	General purpose I/O. Register enabled pull-up
	AN1	ACERL	AN	—	A/D Converter external input channel
PD2/AN2	PD2	PDPUP	ST	CMOS	General purpose I/O. Register enabled pull-up
	AN2	ACERL	AN	—	A/D Converter external input channel
PD3/AN3	PD3	PDPUP	ST	CMOS	General purpose I/O. Register enabled pull-up
	AN3	ACERL	AN	—	A/D Converter external input channel
PD4/AN4/VREF	PD4	PDPUP	ST	CMOS	General purpose I/O. Register enabled pull-up
	AN4	ACERL	AN	—	A/D Converter external input channel
	VREF	TMPC	AN	—	A/D Converter external reference voltage input
PD5/PTP0/AN5	PD5	PDPUP	ST	CMOS	General purpose I/O. Register enabled pull-up
	PTP0	TMPC	—	CMOS	PTM0 output
	AN5	ACERL	AN	—	A/D Converter external input channel
PD6/SCL/[RX0]/AN6	PD6	PDPUP	ST	CMOS	General purpose I/O. Register enabled pull-up
	SCL	IICC0 IFS0	ST	NMOS	I ² C clock line
	RX0	U0CR1 IFS0 IFS2	ST	—	UART0 data receive pin
	AN6	ACERL	AN	—	A/D Converter external input channel
PD7/SDA/[TX0]/AN7	PD7	PDPUP	ST	CMOS	General purpose I/O. Register enabled pull-up
	SDA	IICC0 IFS0	ST	NMOS	I ² C data line
	TX0	U0CR1 IFS0	—	CMOS	UART0 data transmit pin
	AN7	ACERL	AN	—	A/D Converter external input channel
VDD	VDD	—	PWR	—	Positive power supply
VSS	VSS	—	PWR	—	Negative power supply, ground.

Legend: I/T: Input type; O/T: Output type;
 OPT: Optional by register selection;
 PWR: Power; ST: Schmitt Trigger input;
 CMOS: CMOS output; NMOS: NMOS output;
 AN: Analog signal; NSI: Non-standard input.

BS86E16C/BS86EV16C

Pin Name	Function	OPT	I/T	O/T	Description
PA0/[CTP0B]/ICPDA/ OCSDA	PA0	PAPU PAWU	ST	CMOS	General purpose I/O. Register enabled pull-up and wake-up
	CTP0B	TMPC IFS1	—	CMOS	CTM0 inverted output
	ICPDA	—	ST	CMOS	ICP data/address pin
	OCSDA	—	ST	CMOS	OCDS data/address pin, for EV chip only.
PA1/[SCL]/RX0/XT1	PA1	PAPU PAWU	ST	CMOS	General purpose I/O. Register enabled pull-up and wake-up
	SCL	IICC0 IFS0	ST	NMOS	I ² C clock line
	RX0	U0CR1 IFS0 IFS2	ST	—	UART0 data receive pin
	XT1	CO	LXT	—	LXT oscillator pin
PA2/PTP0B/ICPCK/ OCDSCK	PA2	PAPU PAWU	ST	CMOS	General purpose I/O. Register enabled pull-up and wake-up
	PTP0B	TMPC	—	CMOS	PTM0 inverted output
	ICPCK	—	ST	—	ICP clock pin
	OCDSCK	—	ST	—	OCDS clock pin, for EV chip only
PA3/[SDA]/TX0/XT2	PA3	PAPU PAWU	ST	CMOS	General purpose I/O. Register enabled pull-up and wake-up
	SDA	IICC0 IFS0	ST	NMOS	I ² C data line
	TX0	U0CR1 IFS0	—	CMOS	UART0 data transmit pin
	XT2	CO	—	LXT	LXT oscillator pin
PA4/PTP0I/CTP0/INT/ [RX1]	PA4	PAPU PAWU	ST	CMOS	General purpose I/O. Register enabled pull-up and wake-up
	PTP0I	PTM0C0 PTM0C1	ST	—	PTM0 capture input
	CTP0	TMPC IFS1	—	CMOS	CTM0 output
	INT	INTC0 INTEG	ST	—	External interrupt input
	RX1	U1CR1 IFS2	ST	—	UART1 data receive pin
PA7/PTCK0/CTCK0/ [TX1]	PA7	PAPU PAWU	ST	CMOS	General purpose I/O. Register enabled pull-up and wake-up
	PTCK0	PTM0C0	ST	—	PTM0 clock input
	CTCK0	CTM0C0 IFS1	ST	—	CTM0 clock input
	TX1	U1CR1 IFS2	—	CMOS	UART1 data transmit pin
PB0/KEY1~PB3/KEY4	PB0~PB3	PBPU	ST	CMOS	General purpose I/O. Register enabled pull-up
	KEY1~KEY4	TKM0C1	NSI	—	Touch key input
PB4/KEY5~PB7/KEY8	PB4~PB7	PBPU	ST	CMOS	General purpose I/O. Register enabled pull-up
	KEY5~KEY8	TKM1C1	NSI	—	Touch key input
PC0/[CTCK0]/KEY9	PC0	PCPU	ST	CMOS	General purpose I/O. Register enabled pull-up
	CTCK0	CTM0C0 IFS1	ST	—	CTM0 clock input
	KEY9	TKM2C1	NSI	—	Touch key input

Pin Name	Function	OPT	I/T	O/T	Description
PC1/[CTP0]/KEY10	PC1	PCPU	ST	CMOS	General purpose I/O. Register enabled pull-up
	CTP0	TMPC IFS1	—	CMOS	CTM0 output
	KEY10	TKM2C1	NSI	—	Touch key input
PC2/[SCL]/[RX0]/KEY11	PC2	PCPU	ST	CMOS	General purpose I/O. Register enabled pull-up
	SCL	IICC0 IFS0	ST	NMOS	I ² C clock line
	RX0	U0CR1 IFS0 IFS2	ST	—	UART0 data receive pin
	KEY11	TKM2C1	NSI	—	Touch key input
PC3/[SDA]/[TX0]/KEY12	PC3	PCPU	ST	CMOS	General purpose I/O. Register enabled pull-up
	SDA	IICC0 IFS0	ST	NMOS	I ² C data line
	TX0	U0CR1 IFS0	—	CMOS	UART0 data transmit pin
	KEY12	TKM2C1	NSI	—	Touch key input
PC4/KEY13	PC4	PCPU	ST	CMOS	General purpose I/O. Register enabled pull-up
	KEY13	TKM3C1	NSI	—	Touch key input
PC5/KEY14	PC5	PCPU	ST	CMOS	General purpose I/O. Register enabled pull-up
	KEY14	TKM3C1	NSI	—	Touch key input
PC6/[SCL]/KEY15	PC6	PCPU	ST	CMOS	General purpose I/O. Register enabled pull-up
	SCL	IICC0 IFS0	ST	NMOS	I ² C clock line
	KEY15	TKM3C1	NSI	—	Touch key input
PC7/[SDA]/KEY16	PC7	PCPU	ST	CMOS	General purpose I/O. Register enabled pull-up
	SDA	IICC0 IFS0	ST	NMOS	I ² C data line
	KEY16	TKM3C1	NSI	—	Touch key input
PD0/AN0	PD0	PDPUP	ST	CMOS	General purpose I/O. Register enabled pull-up
	AN0	ACERL	AN	—	A/D Converter external input channel
PD1/AN1	PD1	PDPUP	ST	CMOS	General purpose I/O. Register enabled pull-up
	AN1	ACERL	AN	—	A/D Converter external input channel
PD2/[PTP1I]/[RX1]/AN2	PD2	PDPUP	ST	CMOS	General purpose I/O. Register enabled pull-up
	PTP1I	PTM1C0 PTM1C1 IFS1	ST	—	PTM1 capture input
	RX1	U1CR1 IFS2	ST	—	UART1 data receive pin
	AN2	ACERL	AN	—	A/D Converter external input channel
PD3/[PTP1]/[TX1]/AN3	PD3	PDPUP	ST	CMOS	General purpose I/O. Register enabled pull-up
	PTP1	TMPC IFS1	—	CMOS	PTM1 output
	TX1	U1CR1 IFS2	—	CMOS	UART1 data transmit pin
	AN3	ACERL	AN	—	A/D Converter external input channel
PD4/[PTCK1]/AN4/VREF	PD4	PDPUP	ST	CMOS	General purpose I/O. Register enabled pull-up
	PTCK1	PTM1C0 IFS2	ST	—	PTM1 clock input
	AN4	ACERL	AN	—	A/D Converter external input channel
	VREF	TMPC	AN	—	A/D Converter external reference voltage input

Pin Name	Function	OPT	I/T	O/T	Description
PD5/[PTP0]/AN5	PD5	PDPUP	ST	CMOS	General purpose I/O. Register enabled pull-up
	PTP0	TMPC IFS1	—	CMOS	PTM0 output
	AN5	ACERL	AN	—	A/D Converter external input channel
PD6/SCL/[RX0]/AN6	PD6	PDPUP	ST	CMOS	General purpose I/O. Register enabled pull-up
	SCL	IICC0 IFS0	ST	NMOS	I ² C clock line
	RX0	U0CR1 IFS0 IFS2	ST	—	UART0 data receive pin
	AN6	ACERL	AN	—	A/D Converter external input channel
PD7/SDA/[TX0]/AN7	PD7	PDPUP	ST	CMOS	General purpose I/O. Register enabled pull-up
	SDA	IICC0 IFS0	ST	NMOS	I ² C data line
	TX0	U0CR1 IFS0	—	CMOS	UART0 data transmit pin
	AN7	ACERL	AN	—	A/D Converter external input channel
PE0/[RX0]	PE0	PEPUP	ST	CMOS	General purpose I/O. Register enabled pull-up
	RX0	U0CR1 IFS0 IFS2	ST	—	UART0 data receive pin
PE1/[TX0]	PE1	PEPUP	ST	CMOS	General purpose I/O. Register enabled pull-up
	TX0	U0CR1 IFS0	—	CMOS	UART0 data transmit pin
PE2/[RX1]	PE2	PEPUP	ST	CMOS	General purpose I/O. Register enabled pull-up
	RX1	U1CR1 IFS2	ST	—	UART1 data receive pin
PE3/[PTP1B]/[TX1]	PE3	PEPUP	ST	CMOS	General purpose I/O. Register enabled pull-up
	PTP1B	TMPC IFS2	—	CMOS	PTM1 inverted output
	TX1	U1CR1 IFS2	—	CMOS	UART1 data transmit pin
PE4/PTP1/VDDIO	PE4	PEPUP	ST	CMOS	General purpose I/O. Register enabled pull-up
	PTP1	TMPC IFS1	—	CMOS	PTM1 output
	VDDIO	PMPSP	PWR	—	PD7~PD6 pin power supply
PE5/PTP1B	PE5	PEPUP	ST	CMOS	General purpose I/O. Register enabled pull-up
	PTP1B	TMPC IFS2	—	CMOS	PTM1 inverted output
PE6/PTP1I	PE6	PEPUP	ST	CMOS	General purpose I/O. Register enabled pull-up
	PTP1I	PTM1C0 PTM1C1 IFS1	ST	—	PTM1 capture input
PE7/PTCK1	PE7	PEPUP	ST	CMOS	General purpose I/O. Register enabled pull-up
	PTCK1	PTM1C0 IFS2	ST	—	PTM1 clock input
PF0/[CTP0]/RX1	PF0	PFPU	ST	CMOS	General purpose I/O. Register enabled pull-up
	CTP0	TMPC IFS1	—	CMOS	CTM0 output
	RX1	U1CR1 IFS2	ST	—	UART1 data receive pin

Pin Name	Function	OPT	I/T	O/T	Description
PF1/[CTCK0]/TX1	PF1	PFPU	ST	CMOS	General purpose I/O. Register enabled pull-up
	CTCK0	CTM0C0 IFS1	ST	—	CTM0 clock input
	TX1	U1CR1 IFS2	—	CMOS	UART1 data transmit pin
PF2/CTP0B	PF2	PFPU	ST	CMOS	General purpose I/O. Register enabled pull-up
	CTP0B	TMPC IFS1	—	CMOS	CTM0 inverted output
PF3/PTP0	PF3	PFPU	ST	CMOS	General purpose I/O. Register enabled pull-up
	PTP0	TMPC IFS1	—	CMOS	PTM0 output
VDD	VDD	—	PWR	—	Positive power supply
VSS	VSS	—	PWR	—	Negative power supply, ground.

Legend: I/T: Input type; O/T: Output type;
 OPT: Optional by configuration option (CO) or register selection;
 PWR: Power; ST: Schmitt Trigger input;
 CMOS: CMOS output; NMOS: NMOS output;
 AN: Analog signal; NSI: Non-standard input;
 LXT: Low frequency crystal oscillator.

BS86D20C/BS86DV20C

Pin Name	Function	OPT	I/T	O/T	Description
PA0/SDO/PTCK0/ ICPDA/OCSDA	PA0	PAPU PAWU	ST	CMOS	General purpose I/O. Register enabled pull-up and wake-up
	SDO	SIMC0 IFS0	—	CMOS	SIM SPI serial data output
	PTCK0	PTM0C0 IFS1	ST	—	PTM0 clock input
	ICPDA	—	ST	CMOS	ICP data/address pin
	OCSDA	—	ST	CMOS	OCDS data/address pin, for EV chip only.
PA1/[SDI/SDA]/ [TX0]/KEY20	PA1	PAPU PAWU	ST	CMOS	General purpose I/O. Register enabled pull-up and wake-up
	SDI	SIMC0 IFS0	ST	—	SIM SPI serial data input
	SDA	SIMC0 IFS0	ST	NMOS	SIM I2C data line
	TX0	U0CR1 IFS0	—	CMOS	UART0 data transmit pin
	KEY20	TKM4C1	NSI	—	Touch key input
PA2/ $\overline{\text{SCS}}$ /PTP0I/ ICPCK/OCDSCK	PA2	PAPU PAWU	ST	CMOS	General purpose I/O. Register enabled pull-up and wake-up
	$\overline{\text{SCS}}$	SIMC0 SIMC2 IFS0	ST	CMOS	SIM SPI slave select pin
	PTP0I	PTM0C0 PTM0C1 IFS1	ST	—	PTM0 capture input
	ICPCK	—	ST	—	ICP clock pin
	OCDSCK	—	ST	—	OCDS clock pin, for EV chip only

Pin Name	Function	OPT	I/T	O/T	Description
PA3/SDI/SDA/RX0	PA3	PAPU PAWU	ST	CMOS	General purpose I/O. Register enabled pull-up and wake-up
	SDI	SIMC0 IFS0	ST	—	SIM SPI serial data input
	SDA	SIMC0 IFS0	ST	NMOS	SIM I ² C data line
	RX0	U0CR1 IFS0 IFS1	ST	—	UART0 data receive pin
PA4/INT/CTCK0/ [SCK/SCL]/[RX0]/ KEY19	PA4	PAPU PAWU	ST	CMOS	General purpose I/O. Register enabled pull-up and wake-up
	INT	INTC0 INTEG	ST	—	External interrupt input
	CTCK0	CTM0C0	ST	—	CTM0 clock input
	SCK	SIMC0 IFS0	ST	CMOS	SIM SPI serial clock
	SCL	SIMC0 IFS0	ST	NMOS	SIM I ² C clock line
	RX0	U0CR1 IFS0 IFS1	ST	—	UART0 data receive pin
PA7/SCK/SCL/TX0	PA7	PAPU PAWU	ST	CMOS	General purpose I/O. Register enabled pull-up and wake-up
	SCK	SIMC0 IFS0	ST	CMOS	SIM SPI serial clock
	SCL	SIMC0 IFS0	ST	NMOS	SIM I ² C clock line
	TX0	U0CR1 IFS0	—	CMOS	UART0 data transmit pin
PB0/KEY1~PB3/KEY4	PB0~PB3	PBPU	ST	CMOS	General purpose I/O. Register enabled pull-up
	KEY1~KEY4	TKM0C1	NSI	—	Touch key input
PB4/KEY5	PB4	PBPU	ST	CMOS	General purpose I/O. Register enabled pull-up
	KEY5	TKM1C1	NSI	—	Touch key input
PB5/PTCK1/KEY6	PB5	PBPU	ST	CMOS	General purpose I/O. Register enabled pull-up
	PTCK1	PTM1C0	ST	—	PTM1 clock input
	KEY6	TKM1C1	NSI	—	Touch key input
PB6/PTP1/KEY7	PB6	PBPU	ST	CMOS	General purpose I/O. Register enabled pull-up
	PTP1	TMPC	—	CMOS	PTM1 output
	KEY7	TKM1C1	NSI	—	Touch key input
PB7/PTP11/KEY8	PB7	PBPU	ST	CMOS	General purpose I/O. Register enabled pull-up
	PTP11	PTM1C0 PTM1C1	ST	—	PTM1 capture input
	KEY8	TKM1C1	NSI	—	Touch key input
PC0/KEY11/AN0/ VREF	PC0	PCPU	ST	CMOS	General purpose I/O. Register enabled pull-up
	KEY11	TKM2C1	NSI	—	Touch key input
	AN0	ACERL	AN	—	A/D Converter external input channel
	VREF	TMPC	AN	—	A/D Converter external reference voltage input

Pin Name	Function	OPT	I/T	O/T	Description
PC1/KEY12/AN1	PC1	PCPU	ST	CMOS	General purpose I/O. Register enabled pull-up
	KEY12	TKM2C1	NSI	—	Touch key input
	AN1	ACERL	AN	—	A/D Converter external input channel
PC2/[PTCK0]/KEY13/ AN2	PC2	PCPU	ST	CMOS	General purpose I/O. Register enabled pull-up
	PTCK0	PTM0C0 IFS1	ST	—	PTM0 clock input
	KEY13	TKM3C1	NSI	—	Touch key input
	AN2	ACERL	AN	—	A/D Converter external input channel
PC3/[PTP0I]/KEY14/ AN3	PC3	PCPU	ST	CMOS	General purpose I/O. Register enabled pull-up
	PTP0I	PTM0C0 PTM0C1 IFS1	ST	—	PTM0 capture input
	KEY14	TKM3C1	NSI	—	Touch key input
	AN3	ACERL	AN	—	A/D Converter external input channel
PC4/[SCS]/KEY15/ AN4	PC4	PCPU	ST	CMOS	General purpose I/O. Register enabled pull-up
	SCS	SIMC0 SIMC2 IFS0	ST	CMOS	SIM SPI slave select pin
	KEY15	TKM3C1	NSI	—	Touch key input
	AN4	ACERL	AN	—	A/D Converter external input channel
PC5/[SDO]/KEY16/ AN5	PC5	PCPU	ST	CMOS	General purpose I/O. Register enabled pull-up
	SDO	SIMC0 IFS0	—	CMOS	SIM SPI serial data output
	KEY16	TKM3C1	NSI	—	Touch key input
	AN5	ACERL	AN	—	A/D Converter external input channel
PC6/PTP0/KEY17/ AN6	PC6	PCPU	ST	CMOS	General purpose I/O. Register enabled pull-up
	PTP0	TMPC	—	CMOS	PTM0 output
	KEY17	TKM3C1	NSI	—	Touch key input
	AN6	ACERL	AN	—	A/D Converter external input channel
PC7/CTP0/KEY18/ AN7	PC7	PCPU	ST	CMOS	General purpose I/O. Register enabled pull-up
	CTP0	TMPC	—	CMOS	CTM0 output
	KEY18	TKM3C1	NSI	—	Touch key input
	AN7	ACERL	AN	—	A/D Converter external input channel
PD0/PTP0B/[RX0]/ XT1	PD0	PDPUP	ST	CMOS	General purpose I/O. Register enabled pull-up
	PTP0B	TMPC	—	CMOS	PTM0 inverted output
	RX0	U0CR1 IFS0 IFS1	ST	—	UART0 data receive pin
	XT1	CO	LXT	—	LXT oscillator pin
PD1/CTP0B/[TX0]/ XT2	PD1	PDPUP	ST	CMOS	General purpose I/O. Register enabled pull-up
	CTP0B	TMPC	—	CMOS	CTM0 inverted output
	TX0	U0CR1 IFS0	—	CMOS	UART0 data transmit pin
	XT2	CO	—	LXT	LXT oscillator pin
PD2/KEY10	PD2	PDPUP	ST	CMOS	General purpose I/O. Register enabled pull-up
	KEY10	TKM2C1	NSI	—	Touch key input
PD3/PTP1B/KEY9	PD3	PDPUP	ST	CMOS	General purpose I/O. Register enabled pull-up
	PTP1B	TMPC	—	CMOS	PTM1 inverted output
	KEY9	TKM2C1	NSI	—	Touch key input

Pin Name	Function	OPT	I/T	O/T	Description
VDD	VDD	—	PWR	—	Positive power supply
VSS	VSS	—	PWR	—	Negative power supply, ground.

Legend: I/T: Input type; O/T: Output type;
 OPT: Optional by configuration option (CO) or register selection;
 PWR: Power; ST: Schmitt Trigger input;
 CMOS: CMOS output; NMOS: NMOS output;
 AN: Analog signal; NSI: Non-standard input;
 LXT: Low frequency crystal oscillator.

Absolute Maximum Ratings

Supply Voltage	$V_{SS}-0.3V$ to $+6.0V$
Input Voltage	$V_{SS}-0.3V$ to $V_{DD}+0.3V$
Storage Temperature.....	$-60^{\circ}C$ to $150^{\circ}C$
Operating Temperature.....	$-40^{\circ}C$ to $85^{\circ}C$
I_{OH} Total	$-80mA$
I_{OL} Total	$100mA$
Total Power Dissipation	$500mW$

Note: These are stress ratings only. Stresses exceeding the range specified under “Absolute Maximum Ratings” may cause substantial damage to these devices. Functional operation of these devices at other conditions beyond those listed in the specification is not implied and prolonged exposure to extreme conditions may affect device reliability.

D.C. Electrical Characteristics

For data in the following tables, note that factors such as oscillator type, operating voltage, operating frequency, pin load conditions, temperature and program instruction type, can all exert an influence on the measured values.

Operating Voltage Characteristics

$T_a=-40^{\circ}C\sim 85^{\circ}C$

Symbol	Parameter	Test Conditions	Min.	Typ.	Max.	Unit
V_{DD}	Operating Voltage – HIRC	$f_{SYS}=f_{HIRC}=8MHz$	2.2	—	5.5	V
		$f_{SYS}=f_{HIRC}=12MHz$	2.7	—	5.5	
		$f_{SYS}=f_{HIRC}=16MHz$	3.3	—	5.5	
	Operating Voltage – LXT (BS86E16C/BS86D20C)	$f_{SYS}=f_{LXT}=32.768kHz$	2.2	—	5.5	V
	Operating Voltage – LIRC	$f_{SYS}=f_{LIRC}=32kHz$	2.2	—	5.5	V

Operating Current Characteristics

Ta=25°C

Symbol	Parameter	Test Conditions		Min.	Typ.	Max.	Unit
		V _{DD}	Conditions				
I _{DD}	SLOW Mode – LIRC	2.2V	f _{SYS} =f _{LIRC} =32kHz, LVR enable	—	25	50	μA
		3V		—	28	56	
		5V		—	36	72	
	SLOW Mode – LXT (BS86E16C/BS86D20C)	2.2V	f _{SYS} =f _{LXT} =32768Hz, LXTLP=0	—	27	55	μA
		3V		—	30	60	
		5V		—	48	96	
		2.2V	f _{SYS} =f _{LXT} =32768Hz, LXTLP=1	—	24	48	μA
		3V		—	25	50	
	5V	—	36	72			
	FAST Mode – HIRC	2.2V	f _{SYS} =f _{HIRC} =8MHz	—	1	1.6	mA
		3V		—	1.2	1.8	
		5V		—	2.2	3.3	
		2.7V	f _{SYS} =f _{HIRC} =12MHz	—	1.4	2.2	mA
		3V		—	1.6	2.4	
		5V		—	3.3	5	
3.3V		f _{SYS} =f _{HIRC} =16MHz	—	2.0	3.5	mA	
5V	—		4.0	6.0			

Note: When using the characteristic table data, the following notes should be taken into consideration:

1. Any digital input is setup in a non-floating condition.
2. All measurements are taken under conditions of no load and with all peripherals in an off state.
3. There are no DC current paths.
4. All Operating Current values are measured using a continuous NOP instruction program loop.

Standby Current Characteristics

Ta=25°C, unless otherwise specified

Symbol	Parameter	Test Conditions		Min.	Typ.	Max.	Max. @85°C	Unit
		V _{DD}	Conditions					
I _{STB}	SLEEP Mode	2.2V	WDT on	—	1.2	2.4	3.0	μA
		3V		—	1.5	3	3.7	
		5V		—	3	5	6	
	IDLE0 Mode – LIRC	2.2V	f _{SUB} =f _{LIRC} on	—	2.4	4	4.6	μA
		3V		—	3	5	5.7	
		5V		—	5	10	11	
	IDLE0 Mode – LXT (BS86E16C/BS86D20C)	2.2V	f _{SUB} =f _{LXT} on, LXTLP=0	—	4	8	8	μA
		3V		—	5	10	11	
		5V		—	18	30	32	
		2.2V	f _{SUB} =f _{LXT} on, LXTLP=1	—	2	4	4.6	μA
		3V		—	2.5	5	5.7	
		5V		—	6	10	11	
	IDLE1 Mode – HIRC	2.2V	f _{SUB} on, f _{SYS} =8MHz	—	0.6	1	1	mA
		3V		—	0.8	1.2	1.2	
5V		—		1.0	2.0	2.0		
2.7V		f _{SUB} on, f _{SYS} =12MHz	—	0.7	1.2	1.2	mA	
3V			—	0.9	1.4	1.4		
5V			—	1.4	2.1	2.1		
3.3V		f _{SUB} on, f _{SYS} =16MHz	—	1.6	3.2	3.2	mA	
5V	—		2.0	4.0	4.0			

Note: When using the characteristic table data, the following notes should be taken into consideration:

1. Any digital input is setup in a non-floating condition.
2. All measurements are taken under conditions of no load and with all peripherals in an off state.
3. There are no DC current paths.
4. All Standby Current values are taken after a HALT instruction executed thus stopping all instruction execution.

A.C. Characteristics

For data in the following tables, note that factors such as oscillator type, operating voltage, operating frequency and temperature etc., can all exert an influence on the measured values.

High Speed Internal Oscillator – HIRC – Frequency Accuracy

During the program writing operation the writer will trim the HIRC oscillator at a user selected HIRC frequency and user selected voltage of either 3V or 5V.

Symbol	Parameter	Test Conditions		Min.	Typ.	Max.	Unit
		V _{DD}	Temp.				
f _{HIRC}	8MHz Writer Trimmed HIRC Frequency	3V/5V	25°C	-1%	8	+1%	MHz
			-40°C~85°C	-2%	8	+2%	
		2.2V~5.5V	25°C	-2.5%	8	+2.5%	
			-40°C~85°C	-3%	8	+3%	
	12MHz Writer Trimmed HIRC Frequency	3V/5V	25°C	-1%	12	+1%	MHz
			-40°C~85°C	-2%	12	+2%	
		2.7V~5.5V	25°C	-2.5%	12	+2.5%	
			-40°C~85°C	-3%	12	+3%	
	16MHz Writer Trimmed HIRC Frequency	5V	25°C	-1%	16	+1%	MHz
			-40°C~85°C	-2%	16	+2%	
		3.3V~5.5V	25°C	-2.5%	16	+2.5%	
			-40°C~85°C	-3%	16	+3%	

Note: 1. The 3V/5V values for V_{DD} are provided as these are the two selectable fixed voltages at which the HIRC frequency is trimmed by the writer.

2. The row below the 3V/5V trim voltage row is provided to show the values for the full V_{DD} range operating voltage. It is recommended that the trim voltage is fixed at 3V for application voltage ranges from 2.2V to 3.6V and fixed at 5V for application voltage ranges from 3.3V to 5.5V.

3. The minimum and maximum tolerance values provided in the table are only for the frequency at which the writer trims the HIRC oscillator. After trimming at this chosen specific frequency any change in HIRC oscillator frequency using the oscillator register control bits by the application program will give a frequency tolerance to within ±20%.

Low Speed Oscillators Characteristics – LIRC & LXT

Symbol	Parameter	Test Conditions		Min.	Typ.	Max.	Unit
		V _{DD}	Temp.				
f _{LIRC}	LIRC Frequency	2.2V~5.5V	25°C	-10%	32	+10%	kHz
			-40°C~85°C	-50%	32	+60%	
t _{START}	LIRC Start Up Time	—	-40°C~85°C	—	—	500	μs
f _{LXT}	LXT Frequency (BS86E16C/BS86D20C)	—	25°C	—	32.768	—	kHz

Operating Frequency Characteristic Curves

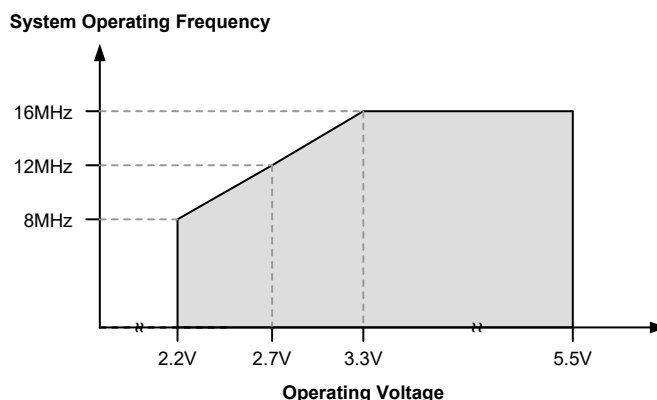

System Start Up Time Characteristics

Ta=-40°C~85°C

Symbol	Parameter	Test Conditions		Min.	Typ.	Max.	Unit
		V _{DD}	Conditions				
t _{SST}	System Start-up Time Wake-up from condition where f _{sys} is off	—	f _{sys} =f _H ~f _H /64, f _H =f _{HIRC}	—	16	—	t _{HIRC}
		—	f _{sys} =f _{SUB} =f _{LIRC}	—	2	—	t _{LIRC}
		—	f _{sys} =f _{SUB} =*f _{LXT}	—	128	—	t _{LXT}
	System Start-up Time Wake-up from condition where f _{sys} is on	—	f _{sys} =f _H ~f _H /64, f _H =f _{HIRC}	—	2	—	t _H
		—	f _{sys} =f _{SUB} =f _{LIRC} or *f _{LXT}	—	2	—	t _{SUB}
	System Speed Switch Time FAST to SLOW Mode or SLOW to FAST Mode	—	f _{HIRC} switches from off → on	—	16	—	t _{HIRC}
—		*f _{LXT} switches from off → on	—	128	—	t _{LXT}	
t _{RSTD}	System Reset Delay Time Reset source from Power-on reset or LVR hardware reset	—	RR _{POR} =5V/ms	42	48	54	ms
	System Reset Delay Time LVRC/WDT software reset	—	—	—	—	—	—
	System Reset Delay Time Reset source from WDT overflow	—	—	14	16	18	ms
t _{SRESET}	Minimum Software Reset Width to Reset	—	—	45	90	120	μs

- Note: 1. For the System Start-up time values, whether f_{sys} is on or off depends upon the mode type and the chosen f_{sys} system oscillator. Details are provided in the System Operating Modes section.
2. The time units, shown by the symbols t_{HIRC}, t_{sys} etc. are the inverse of the corresponding frequency values as provided in the frequency tables. For example t_{HIRC}=1/f_{HIRC}, t_{sys}=1/f_{sys} etc.
3. If the LIRC is used as the system clock and if it is off when in the SLEEP Mode, then an additional LIRC start up time, t_{START}, as provided in the LIRC frequency table, must be added to the t_{SST} time in the table above.
4. The System Speed Switch Time is effectively the time taken for the newly activated oscillator to start up.
5. The LXT oscillator is only available for the BS86E16C/BS86D20C device.

Input/Output Characteristics

Ta=25°C

Symbol	Parameter	Test Conditions		Min.	Typ.	Max.	Unit
		V _{DD}	Conditions				
V _{IL}	Input Low Voltage for I/O Ports	5V	—	0	—	1.5	V
		—	—	0	—	0.2V _{DD}	
V _{IH}	Input High Voltage for I/O Ports	5V	—	3.5	—	5.0	V
		—	—	0.8V _{DD}	—	V _{DD}	
I _{OL}	Sink Current for I/O Ports (PA, PC, PD, PE, PF)	3V	V _{OL} =0.1V _{DD} , PxNS=0, x=A, C, D, E or F	16	32	—	mA
			V _{OL} =0.1V _{DD} , PxNS=1, x=A, C, D, E or F	25	50	—	
		5V	V _{OL} =0.1V _{DD} , PxNS=0, x=A, C, D, E or F	32	64	—	
			V _{OL} =0.1V _{DD} , PxNS=1, x=A, C, D, E or F	50	100	—	
Sink Current for I/O Ports (PB)	3V	—	16	32	—	mA	
	5V	V _{OL} =0.1V _{DD}	32	64	—		
I _{OH}	Source Current for I/O Ports	3V	V _{OH} =0.9V _{DD} , PxPS=00	-1.0	-2.0	—	mA
		5V		-2.0	-4.0	—	
		3V	V _{OH} =0.9V _{DD} , PxPS=01	-1.75	-3.5	—	
		5V		-3.5	-7.0	—	
		3V	V _{OH} =0.9V _{DD} , PxPS=10	-2.5	-5.0	—	
		5V		-5.0	-10	—	
		3V	V _{OH} =0.9V _{DD} , PxPS=11	-5.5	-11	—	
		5V		-11	-22	—	
R _{PH}	Pull-high Resistance for I/O Ports ^(Note)	3V	—	20	60	100	kΩ
		5V	—	10	30	50	
t _{TCK}	TM Clock Input Pin Minimum Pulse Width	—	—	0.3	—	—	μs
t _{TPi}	TM Capture Input Pin Minimum Pulse Width	—	—	0.3	—	—	μs
f _{TMCLK}	TM Maximum Timer Clock Source Frequency	5V	—	—	—	1	f _{sys}
t _{CPW}	TM Minimum Capture Pulse Width	—	—	2	—	—	t _{TMCLK}
t _{INT}	External Interrupt Minimum Pulse Width	—	—	10	—	—	μs

Note: The R_{PH} internal pull high resistance value is calculated by connecting to ground and enabling the input pin with a pull-high resistor and then measuring the pin current at the specified supply voltage level. Dividing the voltage by this measured current provides the R_{PH} value.

Memory Characteristics

Ta=-40°C~85°C, unless otherwise specified

Symbol	Parameter	Test Conditions		Min.	Typ.	Max.	Unit
		V _{DD}	Conditions				
V _{RW}	V _{DD} for Read / Write	—	—	V _{DDmin}	—	V _{DDmax}	V
Flash Program / Data EEPROM Memory							
t _{DEW}	Erase / Write Cycle Time – Flash Program Memory	—	—	—	2	3	ms
	Write Cycle Time – Data EEPROM Memory	—	—	—	4	6	ms
I _{DDPGM}	Programming / Erase Current on V _{DD}	—	—	—	—	5.0	mA
E _P	Cell Endurance – Flash Program Memory	—	—	10K	—	—	E/W
	Cell Endurance – Data EEPROM Memory	—	—	100K	—	—	E/W
t _{RETD}	ROM Data Retention Time	—	Ta=25°C	—	40	—	Year
RAM Data Memory							
V _{DR}	RAM Data Retention Voltage	—	—	1.0	—	—	V

Note: “E/W” means Erase/Write times.

LVD/LVR Electrical Characteristics

Ta=-40°C~85°C

Symbol	Parameter	Test Conditions		Min.	Typ.	Max.	Unit
		V _{DD}	Conditions				
V _{LVR}	Low Voltage Reset Voltage	—	LVR enable, voltage select 2.1V	-5%	2.1	+5%	V
		—	LVR enable, voltage select 2.55V		2.55		
		—	LVR enable, voltage select 3.15V		3.15		
		—	LVR enable, voltage select 3.8V		3.8		
V _{LVD}	Low Voltage Detection Voltage	—	LVD enable, voltage select 2.0V	-5%	2.0	+5%	V
		—	LVD enable, voltage select 2.2V		2.2		
		—	LVD enable, voltage select 2.4V		2.4		
		—	LVD enable, voltage select 2.7V		2.7		
		—	LVD enable, voltage select 3.0V		3.0		
		—	LVD enable, voltage select 3.3V		3.3		
		—	LVD enable, voltage select 3.6V		3.6		
		—	LVD enable, voltage select 4.0V		4.0		
I _{LVRLVDBG}	Operating Current	3V	LVD enable, LVR enable, VBGEN = 0	—	—	18	μA
		5V	LVD enable, LVR enable, VBGEN = 0	—	20	25	μA
		3V	LVD enable, LVR enable, VBGEN = 1	—	—	150	μA
		5V	LVD enable, LVR enable, VBGEN = 1	—	180	200	μA
t _{LVDS}	LVDO Stable Time	—	For LVR enable, VBGEN=0, LVD off → on	—	—	15	μs
t _{LVR}	Minimum Low Voltage Width to Reset	—	—	120	240	480	μs
t _{LVD}	Minimum Low Voltage Width to Interrupt	—	—	60	120	240	μs

A/D Converter Electrical Characteristics

Ta=-40°C~85°C

Symbol	Parameter	Test Conditions		Min.	Typ.	Max.	Unit
		V _{DD}	Conditions				
V _{DD}	Operating Voltage	—	—	2.2	—	5.5	V
V _{ADI}	Input Voltage	—	—	0	—	V _{REF}	V
V _{REF}	Reference Voltage	—	—	2	—	V _{DD}	V
N _R	Resolution	—	—	—	—	12	Bit
DNL	Differential Non-linearity	—	V _{REF} =V _{DD} , t _{ADCK} =0.5μs	-3	—	+3	LSB
INL	Integral Non-linearity	—	V _{REF} =V _{DD} , t _{ADCK} =0.5μs	-4	—	+4	LSB
I _{ADC}	Additional Current Consumption for A/D Converter Enable	2.2V	No load, t _{ADCK} =0.5μs	—	300	420	μA
		3V		—	340	500	μA
		5V		—	500	700	μA
t _{ADCK}	Clock Period	—	—	0.5	—	10	μs
t _{ON2ST}	A/D Converter On-to-Start Time	—	—	4	—	—	μs
t _{ADC}	Conversion Time (Including A/D Sample and Hold Time)	—	—	—	16	—	t _{ADCK}
t _{ADS}	Sampling Time	—	—	—	4	—	t _{ADCK}

Internal Reference Voltage Characteristics

Ta=-40°C~85°C

Symbol	Parameter	Test Conditions		Min.	Typ.	Max.	Unit
		V _{DD}	Conditions				
V _{BG}	Bandgap Reference Voltage	—	—	-3%	1.09	+3%	V
I _{BG}	Additional Current for Bandgap Reference Enable	—	—	—	200	300	μA
t _{BGS}	V _{BG} Turn-on Stable Time	—	No load	—	—	200	μs

- Note: 1. All the above parameters are measured under conditions of no load condition unless otherwise described.
 2. A 0.1μF ceramic capacitor should be connected between V_{DD} and GND.
 3. The V_{BG} voltage is used as the A/D converter internal signal input.

Power-on Reset Characteristics

Ta=25°C

Symbol	Parameter	Test Conditions		Min.	Typ.	Max.	Unit
		V _{DD}	Conditions				
V _{POR}	V _{DD} Start Voltage to Ensure Power-on Reset	—	—	—	—	100	mV
RR _{POR}	V _{DD} Rising Rate to Ensure Power-on Reset	—	—	0.035	—	—	V/ms
t _{POR}	Minimum Time for V _{DD} Stays at V _{POR} to Ensure Power-on Reset	—	—	1	—	—	ms

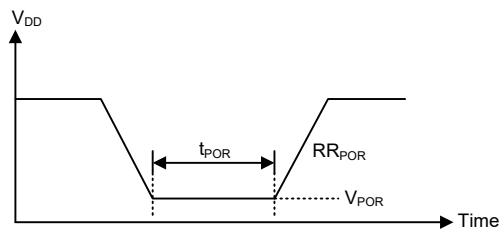

System Architecture

A key factor in the high-performance features of the range of microcontrollers is attributed to their internal system architecture. These devices take advantage of the usual features found within RISC microcontrollers providing increased speed of operation and enhanced performance. The pipelining scheme is implemented in such a way that instruction fetching and instruction execution are overlapped, hence instructions are effectively executed in one or two cycles for most of the standard or extended instructions respectively. The exceptions to this are branch or call instructions which need one more cycle. An 8-bit wide ALU is used in practically all instruction set operations, which carries out arithmetic operations, logic operations, rotation, increment, decrement, branch decisions, etc. The internal data path is simplified by moving data through the Accumulator and the ALU. Certain internal registers are implemented in the Data Memory and can be directly or indirectly addressed. The simple addressing methods of these registers along with additional architectural features ensure that a minimum of external components is required to provide a functional I/O and A/D control system with maximum reliability and flexibility. This makes these devices suitable for low-cost, high-volume production for controller applications.

Clocking and Pipelining

The main system clock, derived from either a HIRC, LIRC or LXT oscillator is subdivided into four internally generated non-overlapping clocks, T1~T4. Note that the LXT oscillator is only available for the BS86E16C/BS86D20C device. The Program Counter is incremented at the beginning of the T1 clock during which time a new instruction is fetched. The remaining T2~T4 clocks carry out the decoding and execution functions. In this way, one T1~T4 clock cycle forms one instruction cycle. Although the fetching and execution of instructions takes place in consecutive instruction cycles, the pipelining structure of the microcontroller ensures that instructions are effectively executed in one instruction cycle. The exception to this are instructions where the contents of the Program Counter are changed, such as subroutine calls or jumps, in which case the instruction will take one more instruction cycle to execute.

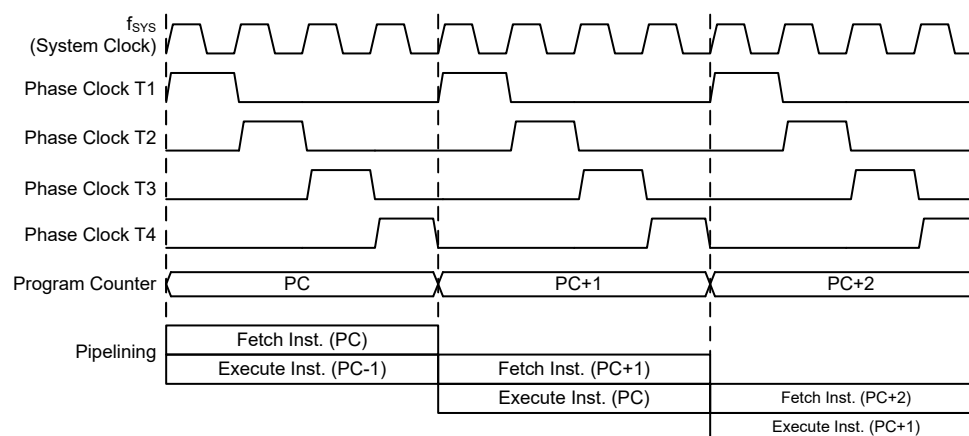

System Clocking and Pipelining

For instructions involving branches, such as jump or call instructions, two machine cycles are required to complete instruction execution. An extra cycle is required as the program takes one cycle to first obtain the actual jump or call address and then another cycle to actually execute the branch. The requirement for this extra cycle should be taken into account by programmers in timing sensitive applications.

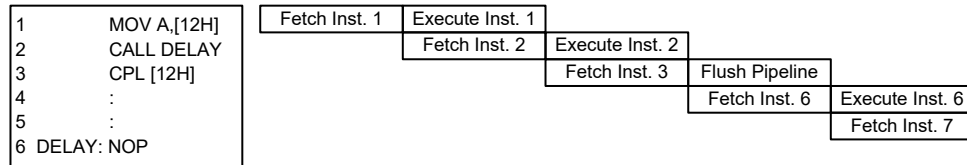

Instruction Fetching

Program Counter

During program execution, the Program Counter is used to keep track of the address of the next instruction to be executed. It is automatically incremented by one each time an instruction is executed except for instructions, such as “JMP” or “CALL” that demand a jump to a non-consecutive Program Memory address. For the device whose memory capacity is greater than 8K words, the Program Memory address may be located in a certain program memory bank which is selected by the program memory bank pointer bit, PBP0. Only the lower 8 bits, known as the Program Counter Low Register, are directly addressable by the application program.

When executing instructions requiring jumps to non-consecutive addresses such as a jump instruction, a subroutine call, interrupt or reset, etc., the microcontroller manages program control by loading the required address into the Program Counter. For conditional skip instructions, once the condition has been met, the next instruction, which has already been fetched during the present instruction execution, is discarded and a dummy cycle takes its place while the correct instruction is obtained.

Device	Program Counter	
	High Byte	Low Byte (PCL)
BS86C08C	PC11~PC8	PCL7~PCL0
BS86D12C	PC12~PC8	PCL7~PCL0
BS86E16C	PBP0, PC12~PC8	PCL7~PCL0
BS86D20C	PC12~PC8	PCL7~PCL0

Program Counter

The lower byte of the Program Counter, known as the Program Counter Low register or PCL, is available for program control and is a readable and writeable register. By transferring data directly into this register, a short program jump can be executed directly; however, as only this low byte is available for manipulation, the jumps are limited to the present page of memory that is 256 locations. When such program jumps are executed it should also be noted that a dummy cycle will be inserted. Manipulating the PCL register may cause program branching, so an extra cycle is needed to pre-fetch.

Stack

This is a special part of the memory which is used to save the contents of the Program Counter only. The stack is organized into 8 levels and neither part of the data nor part of the program space, and is neither readable nor writeable. The activated level is indexed by the Stack Pointer, and is neither readable nor writeable. At a subroutine call or interrupt acknowledge signal, the contents of the Program Counter are pushed onto the stack. At the end of a subroutine or an interrupt routine, signaled by a return instruction, RET or RETI, the Program Counter is restored to its previous value from the stack. After a device reset, the Stack Pointer will point to the top of the stack.

If the stack is full and an enabled interrupt takes place, the interrupt request flag will be recorded but the acknowledge signal will be inhibited. When the Stack Pointer is decremented, by RET or RETI, the interrupt will be serviced. This feature prevents stack overflow allowing the programmer to use the structure more easily. However, when the stack is full, a CALL subroutine instruction can still be executed which will result in a stack overflow. Precautions should be taken to avoid such cases which might cause unpredictable program branching.

If the stack is overflow, the first Program Counter save in the stack will be lost.

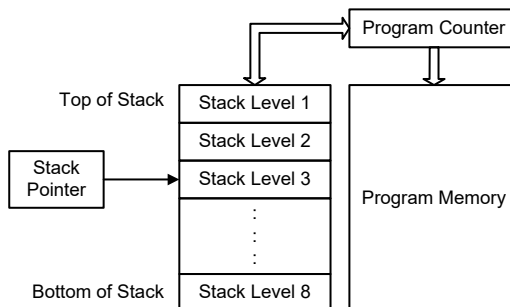

Arithmetic and Logic Unit – ALU

The arithmetic-logic unit or ALU is a critical area of the microcontroller that carries out arithmetic and logic operations of the instruction set. Connected to the main microcontroller data bus, the ALU receives related instruction codes and performs the required arithmetic or logical operations after which the result will be placed in the specified register. As these ALU calculation or operations may result in carry, borrow or other status changes, the status register will be correspondingly updated to reflect these changes. The ALU supports the following functions:

- Arithmetic operations:
ADD, ADDM, ADC, ADCM, SUB, SUBM, SBC, SBCM, DAA,
LADD, LADDM, LADC, LADCM, LSUB, LSUBM, LSBC, LSBCM, LDAA
- Logic operations:
AND, OR, XOR, ANDM, ORM, XORM, CPL, CPLA,
LAND, LOR, LXOR, LANDM, LORM, LXORM, LCPL, LCPLA
- Rotation:
RRA, RR, RRCA, RRC, RLA, RL, RLCA, RLC,
LRR, LRRCA, LRR, LRL, LRLCA, LRLC
- Increment and Decrement:
INCA, INC, DECA, DEC,
LINCA, LINC, LDECA, LDEC
- Branch decision:
JMP, SZ, SZA, SNZ, SIZ, SDZ, SIZA, SDZA, CALL, RET, RETI,
LSZ, LSZA, LSNZ, LSIZ, LSDZ, LSIZA, LSDZA

Flash Program Memory

The Program Memory is the location where the user code or program is stored. For these devices the Program Memory is Flash type, which means it can be programmed and re-programmed a large number of times, allowing the user the convenience of code modification on the same device. By using the appropriate programming tools, the Flash devices offer users the flexibility to conveniently debug and develop their applications while also offering a means of field programming and updating.

Device	Capacity	Banks
BS86C08C	4K×16	0
BS86D12C	8K×16	0
BS86E16C	16K×16	0, 1
BS86D20C	8K×16	0

Structure

The Program Memory has a capacity of 4K×16 to 16K×16 bits. The Program Memory is addressed by the Program Counter and also contains data, table information and interrupt entries. Table data, which can be setup in any location within the Program Memory, is addressed by a separate table pointer register.

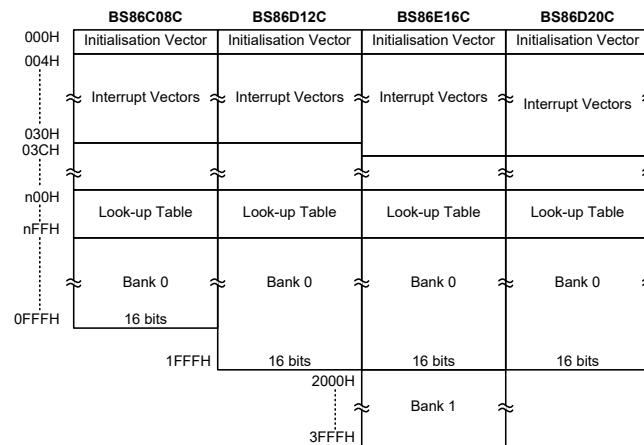

Program Memory Structure

Special Vectors

Within the Program Memory, certain locations are reserved for the reset and interrupts. The location 0000H is reserved for use by the device reset for program initialisation. After a device reset is initiated, the program will jump to this location and begin execution.

Look-up Table

Any location within the Program Memory can be defined as a look-up table where programmers can store fixed data. To use the look-up table, the table pointer must first be setup by placing the address of the look up data to be retrieved in the table pointer register, TBLP and TBHP. These registers define the total address of the look-up table.

After setting up the table pointer, the table data can be retrieved from the Program Memory using the “TABRD [m]” or “TABRDL [m]” instructions respectively when the memory [m] is located in sector 0. If the memory [m] is located in other sectors except sector 0, the data can be retrieved from the program memory using the corresponding extended table read instruction such as “LTABRD [m]”

or “LTABRDL [m]” respectively. When the instruction is executed, the lower order table byte from the Program Memory will be transferred to the user defined Data Memory register [m] as specified in the instruction. The higher order table data byte from the Program Memory will be transferred to the TBLH special register. Any unused bits in this transferred higher order byte will be read as “0”.

The accompanying diagram illustrates the addressing data flow of the look-up table.

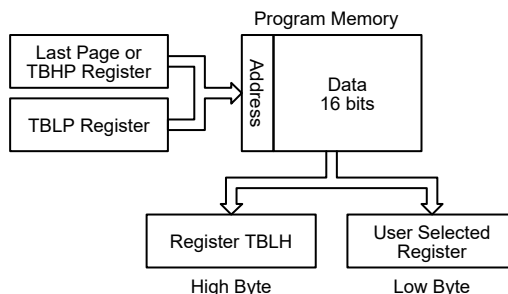

Table Program Example

The following example shows how the table pointer and table data is defined and retrieved from the microcontroller. This example uses raw table data located in the Program Memory which is stored there using the ORG statement. The value at this ORG statement is “1F00H” which refers to the start address of the last page within the 8K Program Memory of the microcontroller. The table pointer low byte register is setup here to have an initial value of “06H”. This will ensure that the first data read from the data table will be at the Program Memory address “1F06H” or 6 locations after the start of the last page. Note that the value for the table pointer is referenced to the specific page pointed by the TBHP register if the “TABRD [m]” or “LTABRD [m]” instruction is being used. The high byte of the table data which in this case is equal to zero will be transferred to the TBLH register automatically when the “TABRD [m]” or “LTABRD [m]” instruction is executed.

Because the TBLH register is a read/write register and can be restored, care should be taken to ensure its protection if both the main routine and Interrupt Service Routine use table read instructions. If using the table read instructions, the Interrupt Service Routines may change the value of the TBLH and subsequently cause errors if used again by the main routine. As a rule it is recommended that simultaneous use of the table read instructions should be avoided. However, in situations where simultaneous use cannot be avoided, the interrupts should be disabled prior to the execution of any main routine table-read instructions. Note that all table related instructions require two instruction cycles to complete their operation.

Table Read Program Example

```

tempreg1 db ?      ; temporary register #1
tempreg2 db ?      ; temporary register #2
:
:
mov a,06h          ; initialise low table pointer - note that this address
                  ; is referenced
mov tblp,a         ; to the last page or the page that tblp pointed
mov a,1Fh          ; initialise high table pointer
mov tbhp,a
:
:
tabrd tempreg1     ; transfers value in table referenced by table pointer data at program
                  ; memory address "1F06H" transferred to tempreg1 and TBLH
dec tblp           ; reduce value of table pointer by one
tabrd tempreg2     ; transfers value in table referenced by table pointer
                  ; data at program memory address "1F05H" transferred to
                  ; tempreg2 and TBLH
                  ; in this example the data "1AH" is transferred to tempreg1 and data "0FH"
                  ; to register tempreg2
:
:
org 1F00h          ; sets initial address of program memory
dc 00Ah, 00Bh, 00Ch, 00Dh, 00Eh, 00Fh, 01Ah, 01Bh
:
:

```

In Circuit Programming – ICP

The provision of Flash type Program Memory provides the user with a means of convenient and easy upgrades and modifications to their programs on the same device.

As an additional convenience, Holtek has provided a means of programming the microcontroller in-circuit using a 4-pin interface. This provides manufacturers with the possibility of manufacturing their circuit boards complete with a programmed or un-programmed microcontroller, and then programming or upgrading the program at a later stage. This enables product manufacturers to easily keep their manufactured products supplied with the latest program releases without removal and re-insertion of the devices.

Holtek Writer Pins	MCU Programming Pins	Pin Description
ICPDA	PA0	Programming Serial Data/Address
ICPCK	PA2	Programming Clock
VDD	VDD (BS86C08C/BS86D12C) VDD & VDDIO (BS86E16C/BS86D20C)	Power Supply
VSS	VSS	Ground

The Program Memory can be programmed serially in-circuit using this 4-wire interface. Data is downloaded and uploaded serially on a single pin with an additional line for the clock. Two additional lines are required for the power supply. The technical details regarding the in-circuit programming of the devices is beyond the scope of this document and will be supplied in supplementary literature.

During the programming process, the user must take care of the ICPDA and ICPCK pins for data and clock programming purposes to ensure that no other outputs are connected to these two pins.

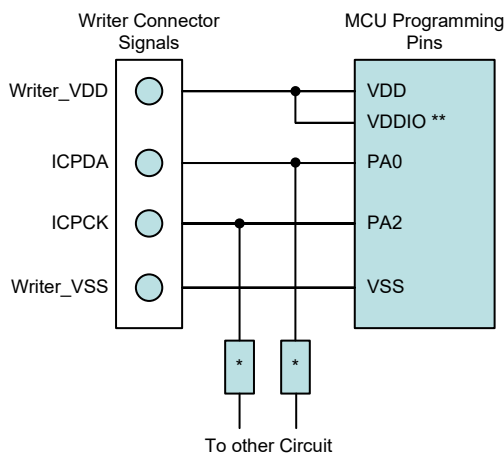

Note: * may be resistor or capacitor. The resistance of * must be greater than 1kΩ or the capacitance of * must be less than 1nF. ** shows the VDDIO pin is only available for the BS86E16C/BS86D20C device.

On-Chip Debug Support – OCDS

There are EV chips named BS86CV08C, BS86DV12C, BS86EV16C and BS86DV20C which are used to emulate the real MCU devices named BS86C08C, BS86D12C, BS86E16C and BS86D20C respectively. The EV chip devices also provide an “On-Chip Debug” function to debug the real MCU devices during the development process. The EV chips and the real MCU devices are almost functionally compatible except for “On-Chip Debug” function. Users can use the EV chip device to emulate the real chip device behavior by connecting the OCSDSA and OCDSCK pins to the Holtek HT-IDE development tools. The OCSDSA pin is the OCDS Data/Address input/output pin while the OCDSCK pin is the OCDS clock input pin. When users use the EV chip device for debugging, the corresponding pin functions shared with the OCSDSA and OCDSCK pins in the real MCU device will have no effect in the EV chip. However, the two OCDS pins which are pin-shared with the ICP programming pins are still used as the Flash Memory programming pins for ICP. For more detailed OCDS information, refer to the corresponding document named “Holtek e-Link for 8-bit MCU OCDS User’s Guide”.

Holtek e-Link Pins	EV Chip OCDS Pins	Pin Description
OCSDSA	OCSDSA	On-Chip Debug Support Data/Address input/output
OCDSCK	OCDSCK	On-Chip Debug Support Clock input
VDD	VDD (BS86CV08C/BS86DV12C) VDD & VDDIO (BS86EV16C/BS86DV20C)	Power Supply
VSS	VSS	Ground

Data Memory

The Data Memory is a volatile area of 8-bit wide RAM internal memory and is the location where temporary information is stored.

Categorized into two types, the first of these is an area of RAM where special function registers are located. These registers have fixed locations and are necessary for correct operation of the devices. Many of these registers can be read from and written to directly under program control, however, some remain protected from user manipulation. The second area of Data Memory is reserved for general purpose use. All locations within this area are read and write accessible under program control.

Structure

The overall Data Memory is subdivided into several sectors, all of which are implemented in 8-bit wide RAM. Each of the Data Memory Sector is categorized into two types, the special Purpose Data Memory and the General Purpose Data Memory. The address range of the Special Purpose Data Memory for the devices is from 00H to 7FH while the General Purpose Data Memory address range is from 80H to FFH. Switching between the different Data Memory sectors is achieved by setting the Memory Pointers to the correct value if using the indirect addressing method.

Device	Special Purpose Data Memory	General Purpose Data Memory	
	Located Sectors	Capacity	Sector: Address
BS86C08C	Sector 0, Sector 1	384×8	Sector 0: 80H~FFH Sector 1: 80H~FFH Sector 2: 80H~FFH
BS86D12C	Sector 0, Sector 1	512×8	Sector 0: 80H~FFH Sector 1: 80H~FFH Sector 2: 80H~FFH Sector 3: 80H~FFH
BS86E16C BS86D20C	Sector 0, Sector 1	768×8	Sector 0: 80H~FFH Sector 1: 80H~FFH Sector 2: 80H~FFH Sector 3: 80H~FFH Sector 4: 80H~FFH Sector 5: 80H~FFH

Data Memory Summary

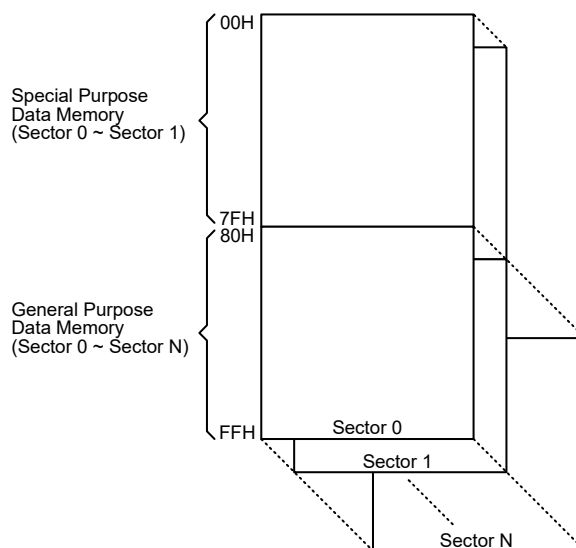

Note: N=1 for BS86C08C; N=3 for BS86D12C; N=5 for BS86E16C/BS86D20C

Data Memory Structure

Data Memory Addressing

For these devices that support the extended instructions, there is no Bank Pointer for Data Memory addressing. The Bank Pointer, PBP, is only available for Program Memory. For Data Memory the desired Sector is pointed by the MP1H or MP2H register and the certain Data Memory address in the selected sector is specified by the MP1L or MP2L register when using indirect addressing access.

Direct Addressing can be used in all sectors using the extended instruction which can address all available data memory space. For the accessed data memory which is located in any data memory sectors except sector 0, the extended instructions can be used to access the data memory instead of using the indirect addressing access. The main difference between standard instructions and extended instructions is that the data memory address “m” in the extended instructions has up to 11 valid bits for these devices, the high byte indicates a sector and the low byte indicates a specific address.

General Purpose Data Memory

All microcontroller programs require an area of read/write memory where temporary data can be stored and retrieved for use later. It is this area of RAM memory that is known as General Purpose Data Memory. This area of Data Memory is fully accessible by the user programming for both reading and writing operations. By using the bit operation instructions individual bits can be set or reset under program control giving the user a large range of flexibility for bit manipulation in the Data Memory.

Special Purpose Data Memory

This area of Data Memory is where registers, necessary for the correct operation of the microcontroller, are stored. Most of the registers are both readable and writable but some are protected and are readable only, the details of which are located under the relevant Special Function Register section. Note that for locations that are unused, any read instruction to these addresses will return the value “00H”.

	Sector 0	Sector 1		Sector 0	Sector 1
00H	IAR0		40H	PDPU	EEC
01H	MP0		41H		
02H	IAR1		42H		
03H	MP1L		43H		
04H	MP1H		44H	TKTMR	
05H	ACC		45H	TKC0	
06H	PCL		46H	TK16DL	
07H	TBLP		47H	TK16DH	
08H	TBLH		48H	TKC1	
09H	TBHP		49H	TKM016DL	
0AH	STATUS		4AH	TKM016DH	
0BH	SMOD		4BH	TKM0ROL	
0CH	IAR2		4CH	TKM0ROH	
0DH	MP2L		4DH	TKM0C0	
0EH	MP2H		4EH	TKM0C1	
0FH	INTEG		4FH	TKM116DL	
10H	INTC0		50H	TKM116DH	
11H	INTC1		51H	TKM1ROL	
12H	INTC2		52H	TKM1ROH	
13H	INTC3		53H	TKM1C0	
14H	PA		54H	TKM1C1	
15H	PAC		55H		
16H	PAPU		56H		
17H	PAWU		57H		
18H	SLEDC0		58H		
19H	SLEDC1		59H		
1AH	WDTA		5AH		
1BH	TBC		5BH		
1CH	PSCR		5CH		
1DH	LVRC		5DH		
1EH	EEA		5EH		
1FH	EED		5FH		
20H	PB	SLEDCOM0	60H		
21H	PBC	SLEDCOM1	61H	CTM0C0	
22H	PBPU	SLEDCOM2	62H	CTM0C1	
23H	IICC0		63H	CTM0DL	
24H	IICC1		64H	CTM0DH	
25H	IICD		65H	CTM0AL	
26H	IICA		66H	CTM0AH	
27H	IICTOC		67H	PTM0C0	
28H	U0SR		68H	PTM0C1	
29H	U0CR1		69H	PTM0DL	
2AH	U0CR2		6AH	PTM0DH	
2BH	TXR_RXR0		6BH	PTM0AL	
2CH	BRG0		6CH	PTM0AH	
2DH	SADOL		6DH	PTM0RPL	
2EH	SAD0H		6EH	PTM0RPH	
2FH	SADC0		6FH		
30H	SADC1		70H		
31H	ACERL		71H		
32H	TMPC		72H		
33H	IFS0		73H		
34H	IFS1		74H		
35H	IFS2		75H		
36H			76H		
37H	LVDC		77H		
38H			78H		
39H	PC		79H		
3AH	PCC		7AH		
3BH	PCPU		7BH		
3CH			7CH		
3DH	CTRL		7DH		
3EH	PD		7EH		
3FH	PDC		7FH		

□: Unused, read as 00H

Special Purpose Data Memory Structure – BS86C08C

	Sector 0	Sector 1		Sector 0	Sector 1
00H	IAR0		40H	PDPU	EEC
01H	MP0		41H		
02H	IAR1		42H		
03H	MP1L		43H		
04H	MP1H		44H	TKTMR	
05H	ACC		45H	TKC0	
06H	PCL		46H	TK16DL	
07H	TBLP		47H	TK16DH	
08H	TBLH		48H	TKC1	
09H	TBHP		49H	TKM016DL	
0AH	STATUS		4AH	TKM016DH	
0BH	SMOD		4BH	TKM0ROL	
0CH	IAR2		4CH	TKM0ROH	
0DH	MP2L		4DH	TKM0C0	
0EH	MP2H		4EH	TKM0C1	
0FH	INTEG		4FH	TKM116DL	
10H	INTC0		50H	TKM116DH	
11H	INTC1		51H	TKM1ROL	
12H	INTC2		52H	TKM1ROH	
13H	INTC3		53H	TKM1C0	
14H	PA		54H	TKM1C1	
15H	PAC		55H	TKM216DL	
16H	PAPU		56H	TKM216DH	
17H	PAWU		57H	TKM2ROL	
18H	SLEDC0		58H	TKM2ROH	
19H	SLEDC1		59H	TKM2C0	
1AH	WDTA		5AH	TKM2C1	
1BH	TBC		5BH		
1CH	PSCR		5CH		
1DH	LVRC		5DH		
1EH	EEA		5EH		
1FH	EED		5FH		
20H	PB	SLEDCOM0	60H		
21H	PBC	SLEDCOM1	61H	CTM0C0	
22H	PBPU	SLEDCOM2	62H	CTM0C1	
23H	IICC0		63H	CTM0DL	
24H	IICC1		64H	CTM0DH	
25H	IICD		65H	CTM0AL	
26H	IICA		66H	CTM0AH	
27H	IICTOC		67H	PTM0C0	
28H	U0SR		68H	PTM0C1	
29H	U0CR1		69H	PTM0DL	
2AH	U0CR2		6AH	PTM0DH	
2BH	TXR_RXR0		6BH	PTM0AL	
2CH	BRG0		6CH	PTM0AH	
2DH	SADOL		6DH	PTM0RPL	
2EH	SAD0H		6EH	PTM0RPH	
2FH	SADC0		6FH		
30H	SADC1		70H		
31H	ACERL		71H		
32H	TMPC		72H		
33H	IFS0		73H		
34H	IFS1		74H		
35H	IFS2		75H		
36H			76H		
37H	LVDC		77H		
38H			78H		
39H	PC		79H		
3AH	PCC		7AH		
3BH	PCPU		7BH		
3CH			7CH		
3DH	CTRL		7DH		
3EH	PD		7EH		
3FH	PDC		7FH		

□: Unused, read as 00H

Special Purpose Data Memory Structure – BS86D12C

	Sector 0	Sector 1		Sector 0	Sector 1
00H	IAR0		40H	PDPU	EEC
01H	MP0		41H	PE	
02H	IAR1		42H	PEC	
03H	MP1L		43H	PEPU	
04H	MP1H		44H	TKTMR	
05H	ACC		45H	TKC0	
06H	PCL		46H	TK16DL	
07H	TBLP		47H	TK16DH	
08H	TBLH		48H	TKC1	
09H	TBHP		49H	TKM016DL	
0AH	STATUS		4AH	TKM016DH	
0BH	PBP		4BH	TKM0ROL	
0CH	IAR2		4CH	TKM0ROH	
0DH	MP2L		4DH	TKM0C0	
0EH	MP2H		4EH	TKM0C1	
0FH	INTEG		4FH	TKM116DL	
10H	INTC0		50H	TKM116DH	
11H	INTC1		51H	TKM1ROL	
12H	INTC2		52H	TKM1ROH	
13H	INTC3		53H	TKM1C0	
14H	PA		54H	TKM1C1	
15H	PAC		55H	TKM216DL	
16H	PAPU		56H	TKM216DH	
17H	PAWU		57H	TKM2ROL	
18H	SLEDC0		58H	TKM2ROH	
19H	SLEDC1		59H	TKM2C0	
1AH	WDTIC		5AH	TKM2C1	
1BH	TBC		5BH	TKM316DL	
1CH	PSCR		5CH	TKM316DH	
1DH	LVRC		5DH	TKM3ROL	
1EH	EEA		5EH	TKM3ROH	
1FH	EED		5FH	TKM3C0	
20H	PB	SLEDCOM0	60H	TKM3C1	
21H	PBC	SLEDCOM1	61H	CTM0C0	
22H	PBPU	SLEDCOM2	62H	CTM0C1	
23H	IICC0	SLEDCOM3	63H	CTM0DL	
24H	IICC1	SLEDCOM4	64H	CTM0DH	
25H	IICD	PMPS	65H	CTM0AL	
26H	IICA		66H	CTM0AH	
27H	IICTOC		67H	PTM0C0	
28H	U0SR		68H	PTM0C1	
29H	U0CR1		69H	PTM0DL	
2AH	U0CR2		6AH	PTM0DH	
2BH	TXR_RXR0		6BH	PTM0AL	
2CH	BRG0		6CH	PTM0AH	
2DH	SADOL		6DH	PTM0RPL	
2EH	SADOH		6EH	PTM0RPH	
2FH	SADC0		6FH	PTM1C0	
30H	SADC1		70H	PTM1C1	
31H	ACERL		71H	PTM1DL	
32H	TMPC		72H	PTM1DH	
33H	IFS0		73H	PTM1AL	
34H	IFS1		74H	PTM1AH	
35H	IFS2		75H	PTM1RPL	
36H			76H	PTM1RPH	
37H	LVDC		77H	U1SR	
38H	SMOD		78H	U1CR1	
39H	PC		79H	U1CR2	
3AH	PCC		7AH	TXR_RXR1	
3BH	PCPU		7BH	BRG1	
3CH	MFI		7CH	PF	
3DH	CTRL		7DH	PFC	
3EH	PD		7EH	PFPU	
3FH	PDC		7FH	SLEDC2	

□: Unused, read as 00H

Special Purpose Data Memory Structure – BS86E16C

	Sector 0	Sector 1		Sector 0	Sector 1
00H	IAR0		40H	PDP	EEC
01H	MP0		41H		
02H	IAR1		42H		
03H	MP1L		43H		
04H	MP1H		44H	TKTMR	
05H	ACC		45H	TKC0	
06H	PCL		46H	TK16DL	
07H	TBLP		47H	TK16DH	
08H	TBLH		48H	TKC1	
09H	TBHP		49H	TKM016DL	
0AH	STATUS		4AH	TKM016DH	
0BH			4BH	TKM0ROL	
0CH	IAR2		4CH	TKM0ROH	
0DH	MP2L		4DH	TKM0C0	
0EH	MP2H		4EH	TKM0C1	
0FH	INTEG		4FH	TKM116DL	
10H	INTC0		50H	TKM116DH	
11H	INTC1		51H	TKM1ROL	
12H	INTC2		52H	TKM1ROH	
13H	INTC3		53H	TKM1C0	
14H	PA		54H	TKM1C1	
15H	PAC		55H	TKM216DL	
16H	PAPU		56H	TKM216DH	
17H	PAWU		57H	TKM2ROL	
18H	SLEDC0		58H	TKM2ROH	
19H	SLEDC1		59H	TKM2C0	
1AH	WDT		5AH	TKM2C1	
1BH	TBC		5BH	TKM316DL	
1CH	PSCR		5CH	TKM316DH	
1DH	LVRC		5DH	TKM3ROL	
1EH	EEA		5EH	TKM3ROH	
1FH	EED		5FH	TKM3C0	
20H	PB	SLEDCOM0	60H	TKM3C1	
21H	PBC	SLEDCOM1	61H	CTM0C0	
22H	PBPU	SLEDCOM2	62H	CTM0C1	
23H	SIMTOC		63H	CTM0DL	
24H	SIMC0		64H	CTM0DH	
25H	SIMC1		65H	CTM0AL	
26H	SIMD		66H	CTM0AH	
27H	SIMC2/SIMA		67H	PTM0C0	
28H	U0SR		68H	PTM0C1	
29H	U0CR1		69H	PTM0DL	
2AH	U0CR2		6AH	PTM0DH	
2BH	TXR_RXR0		6BH	PTM0AL	
2CH	BRG0		6CH	PTM0AH	
2DH	SADOL		6DH	PTM0RPL	
2EH	SADOH		6EH	PTM0RPH	
2FH	SADC0		6FH	PTM1C0	
30H	SADC1		70H	PTM1C1	
31H	ACERL		71H	PTM1DL	
32H	TMPC		72H	PTM1DH	
33H	IFS0		73H	PTM1AL	
34H	IFS1		74H	PTM1AH	
35H			75H	PTM1RPL	
36H			76H	PTM1RPH	
37H	LVDC		77H	TKM416DL	
38H	SMOD		78H	TKM416DH	
39H	PC		79H	TKM4ROL	
3AH	PCC		7AH	TKM4ROH	
3BH	PCPU		7BH	TKM4C0	
3CH	MFI		7CH	TKM4C1	
3DH	CTRL		7DH		
3EH	PD		7EH		
3FH	PDC		7FH		

□: Unused, read as 00H

Special Purpose Data Memory Structure – BS86D20C

Special Function Register Description

Most of the Special Function Register details will be described in the relevant functional sections. However, several registers require a separate description in this section.

Indirect Addressing Registers – IAR0, IAR1, IAR2

The Indirect Addressing Registers, IAR0, IAR1 and IAR2, although having their locations in normal RAM register space, do not actually physically exist as normal registers. The method of indirect addressing for RAM data manipulation uses these Indirect Addressing Registers and Memory Pointers, in contrast to direct memory addressing, where the actual memory address is specified. Actions on the IAR0, IAR1 and IAR2 registers will result in no actual read or write operation to these registers but rather to the memory location specified by their corresponding Memory Pointers, MP0, MP1L/MP1H or MP2L/MP2H. Acting as a pair, IAR0 and MP0 can together access data only from Sector 0 while the IAR1 register together with the MP1L/MP1H register pair and IAR2 register together with the MP2L/MP2H register pair can access data from any Data Memory Sector. As the Indirect Addressing Registers are not physically implemented, reading the Indirect Addressing Registers will return a result of “00H” and writing to the registers will result in no operation.

Memory Pointers – MP0, MP1L, MP1H, MP2L, MP2H

Five Memory Pointers, known as MP0, MP1L, MP1H, MP2L, MP2H, are provided. These Memory Pointers are physically implemented in the Data Memory and can be manipulated in the same way as normal registers providing a convenient way with which to address and track data. When any operation to the relevant Indirect Addressing Registers is carried out, the actual address that the microcontroller is directed to is the address specified by the related Memory Pointer. MP0, together with Indirect Addressing Register, IAR0, are used to access data from Sector 0, while MP1L/MP1H together with IAR1 and MP2L/MP2H together with IAR2 are used to access data from all sectors according to the corresponding MP1H or MP2H register. Direct Addressing can be used in all sectors using the extended instruction which can address all available Data Memory space.

The following example shows how to clear a section of four Data Memory locations already defined as locations `adres1` to `adres4`.

Indirect Addressing Program Example 1

```
data .section 'data'
adres1 db ?
adres2 db ?
adres3 db ?
adres4 db ?
block db ?
code .section at 0 'code'
org 00h
start:
    mov a, 04h                ; setup size of block
    mov block, a
    mov a, offset adres1     ; Accumulator loaded with first RAM address
    mov mp0, a               ; setup memory pointer with first RAM address
loop:
    clr IAR0                 ; clear the data at address defined by MP0
    inc mp0                  ; increment memory pointer
    sdz block                ; check if last memory location has been cleared
    jmp loop
continue:
```

Indirect Addressing Program Example 2

```
data .section 'data'
adres1 db ?
adres2 db ?
adres3 db ?
adres4 db ?
block db ?
code .section at 0 'code'
org 00h
start:
    mov a, 04h                ; setup size of block
    mov block, a
    mov a, 01h                ; setup the memory sector
    mov mplh, a
    mov a, offset adres1     ; Accumulator loaded with first RAM address
    mov mp1l, a              ; setup memory pointer with first RAM address
loop:
    clr IAR1                  ; clear the data at address defined by MP1L
    inc mp1l                  ; increment memory pointer MP1L
    sdz block                 ; check if last memory location has been cleared
    jmp loop
continue:
```

The important point to note here is that in the example shown above, no reference is made to specific Data Memory addresses.

Direct Addressing Program Example using extended instructions

```
data .section 'data'
temp db ?
code .section at 0 'code'
org 00h
start:
    lmov a, [m]               ; move [m] data to acc
    lsub a, [m+1]             ; compare [m] and [m+1] data
    snz c                     ; [m]>[m+1]?
    jmp continue             ; no
    lmov a, [m]               ; yes, exchange [m] and [m+1] data
    mov temp, a
    lmov a, [m+1]
    lmov [m], a
    mov a, temp
    lmov [m+1], a
continue:
```

Note: here “m” is a data memory address located in any data memory sectors. For example, m=1F0H, it indicates address 0F0H in Sector 1.

Program Memory Bank Pointer – PBP

For the BS86E16C device the Program Memory is divided into several banks. Selecting the required Program Memory area is achieved using the Program Memory Bank Pointer, PBP. The PBP register should be properly configured before the device executes the “Branch” operation using the “JMP” or “CALL” instruction. After that a jump to a non-consecutive Program Memory address which is located in a certain bank selected by the program memory bank pointer bits will occur.

• **PBP Register – BS86E16C**

Bit	7	6	5	4	3	2	1	0
Name	—	—	—	—	—	—	—	PBP0
R/W	—	—	—	—	—	—	—	R/W
POR	—	—	—	—	—	—	—	0

Bit 7~1 Unimplemented, read as “0”
 Bit 0 **PBP0**: Select Program Memory Bank
 0: Bank 0
 1: Bank 1

Accumulator – ACC

The Accumulator is central to the operation of any microcontroller and is closely related with operations carried out by the ALU. The Accumulator is the place where all intermediate results from the ALU are stored. Without the Accumulator it would be necessary to write the result of each calculation or logical operation such as addition, subtraction, shift, etc., to the Data Memory resulting in higher programming and timing overheads. Data transfer operations usually involve the temporary storage function of the Accumulator; for example, when transferring data between one user-defined register and another, it is necessary to do this by passing the data through the Accumulator as no direct transfer between two registers is permitted.

Program Counter Low Register – PCL

To provide additional program control functions, the low byte of the Program Counter is made accessible to programmers by locating it within the Special Purpose area of the Data Memory. By manipulating this register, direct jumps to other program locations are easily implemented. Loading a value directly into this PCL register will cause a jump to the specified Program Memory location, however, as the register is only 8-bit wide, only jumps within the current Program Memory page are permitted. When such operations are used, note that a dummy cycle will be inserted.

Look-up Table Registers – TBLP, TBHP, TBLH

These three special function registers are used to control operation of the look-up table which is stored in the Program Memory. TBLP and TBHP are the table pointers and indicate the location where the table data is located. Their value must be setup before any table read commands are executed. Their value can be changed, for example using the “INC” or “DEC” instructions, allowing for easy table data pointing and reading. TBLH is the location where the high order byte of the table data is stored after a table read data instruction has been executed. Note that the lower order table data byte is transferred to a user defined location.

Status Register – STATUS

This 8-bit register contains the SC flag, CZ flag, zero flag (Z), carry flag (C), auxiliary carry flag (AC), overflow flag (OV), power down flag (PDF), and watchdog time-out flag (TO). These arithmetic/logical operation and system management flags are used to record the status and operation of the microcontroller.

With the exception of the TO and PDF flags, bits in the status register can be altered by instructions like most other registers. Any data written into the status register will not change the TO or PDF flag. In addition, operations related to the status register may give different results due to the different instruction operations. The TO flag can be affected only by a system power-up, a WDT time-out or by executing the “CLR WDT” or “HALT” instruction. The PDF flag is affected only by executing the “HALT” or “CLR WDT” instruction or during a system power-up.

The Z, OV, AC, C, SC and CZ flags generally reflect the status of the latest operations.

- C is set if an operation results in a carry during an addition operation or if a borrow does not take place during a subtraction operation; otherwise C is cleared. C is also affected by a rotate through carry instruction.
- AC is set if an operation results in a carry out of the low nibbles in addition, or no borrow from the high nibble into the low nibble in subtraction; otherwise AC is cleared.
- Z is set if the result of an arithmetic or logical operation is zero; otherwise Z is cleared.
- OV is set if an operation results in a carry into the highest-order bit but not a carry out of the highest-order bit, or vice versa; otherwise OV is cleared.
- PDF is cleared by a system power-up or executing the “CLR WDT” instruction. PDF is set by executing the “HALT” instruction.
- TO is cleared by a system power-up or executing the “CLR WDT” or “HALT” instruction. TO is set by a WDT time-out.
- CZ is the operational result of different flags for different instructions. Refer to register definitions for more details.
- SC is the result of the “XOR” operation which is performed by the OV flag and the MSB of the current instruction operation result.

In addition, on entering an interrupt sequence or executing a subroutine call, the status register will not be pushed onto the stack automatically. If the contents of the status registers are important and if the subroutine can corrupt the status register, precautions must be taken to correctly save it.

• **STATUS Register**

Bit	7	6	5	4	3	2	1	0
Name	SC	CZ	TO	PDF	OV	Z	AC	C
R/W	R/W	R/W	R	R	R/W	R/W	R/W	R/W
POR	x	x	0	0	x	x	x	x

“x”: unknown

- Bit 7 **SC**: The result of the “XOR” operation which is performed by the OV flag and the MSB of the instruction operation result.
- Bit 6 **CZ**: The operational result of different flags for different instructions.
 For SUB/SUBM/LSUB/LSUBM instructions, the CZ flag is equal to the Z flag.
 For SBC/SBCM/LSBC/LSBCM instructions, the CZ flag is the “AND” operation result which is performed by the previous operation CZ flag and current operation zero flag.
 For other instructions, the CZ flag will not be affected.
- Bit 5 **TO**: Watchdog Time-out flag
 0: After power up or executing the “CLR WDT” or “HALT” instruction
 1: A watchdog time-out occurred.
- Bit 4 **PDF**: Power down flag
 0: After power up or executing the “CLR WDT” instruction
 1: By executing the “HALT” instruction
- Bit 3 **OV**: Overflow flag
 0: No overflow
 1: An operation results in a carry into the highest-order bit but not a carry out of the highest-order bit or vice versa.
- Bit 2 **Z**: Zero flag
 0: The result of an arithmetic or logical operation is not zero
 1: The result of an arithmetic or logical operation is zero

- Bit 1 **AC:** Auxiliary flag
 0: No auxiliary carry
 1: An operation results in a carry out of the low nibbles in addition, or no borrow from the high nibble into the low nibble in subtraction
- Bit 0 **C:** Carry flag
 0: No carry-out
 1: An operation results in a carry during an addition operation or if a borrow does not take place during a subtraction operation
- The “C” flag is also affected by a rotate through carry instruction.

EEPROM Data Memory

These devices contain an area of internal EEPROM Data Memory. EEPROM is by its nature a non-volatile form of re-programmable memory, with data retention even when its power supply is removed. By incorporating this kind of data memory, a whole new host of application possibilities are made available to the designer. The availability of EEPROM storage allows information such as product identification numbers, calibration values, specific user data, system setup data or other product information to be stored directly within the product microcontroller. The process of reading and writing data to the EEPROM memory has been reduced to a very trivial affair.

Device	Capacity	Address
BS86C08C	32×8	00H~1FH
BS86D12C BS86E16C BS86D20C	64×8	00H~3FH

EEPROM Data Memory Structure

The EEPROM Data Memory capacity varies from 32×8 to 64×8 bits, according to the device selected. Unlike the Program Memory and RAM Data Memory, the EEPROM Data Memory is not directly mapped into memory space and is therefore not directly addressable in the same way as the other types of memory. Read and Write operations to the EEPROM are carried out in single byte operations using an address and a data register in Sector 0 and a single control register in Sector 1.

EEPROM Registers

Three registers control the overall operation of the internal EEPROM Data Memory. These are the address register, EEA, the data register, EED and a single control register, EEC. As both the EEA and EED registers are located in Sector 0, they can be directly accessed in the same way as any other Special Function Register. The EEC register however, being located in only Sector 1, can only be read from or written to indirectly using the MP1L/MP1H or MP2L/MP2H Memory Pointer and Indirect Addressing Register, IAR1/IAR2. If using indirect addressing to access the EEC control register, as it is located at address 40H in Sector 1, the MP1L or MP2L Memory Pointer must first be set to the value 40H and the MP1H or MP2H Memory Pointer high byte set to the value, 01H, before any operations on the EEC register are executed.

Register Name	Bit							
	7	6	5	4	3	2	1	0
EEA (BS86C08C)	—	—	—	EEA4	EEA3	EEA2	EEA1	EEA0
EEA (BS86D12C/BS86E16C/BS86D20C)	—	—	EEA5	EEA4	EEA3	EEA2	EEA1	EEA0
EED	D7	D6	D5	D4	D3	D2	D1	D0
EEC	—	—	—	—	WREN	WR	RDEN	RD

EEPROM Register List

• **EEA Register – BS86C08C**

Bit	7	6	5	4	3	2	1	0
Name	—	—	—	EEA4	EEA3	EEA2	EEA1	EEA0
R/W	—	—	—	R/W	R/W	R/W	R/W	R/W
POR	—	—	—	0	0	0	0	0

Bit 7~5 Unimplemented, read as “0”

Bit 4~0 **EEA4~EEA0**: Data EEPROM address bit 4 ~ bit 0

• **EEA Register – BS86D12C/BS86E16C/BS86D20C**

Bit	7	6	5	4	3	2	1	0
Name	—	—	EEA5	EEA4	EEA3	EEA2	EEA1	EEA0
R/W	—	—	R/W	R/W	R/W	R/W	R/W	R/W
POR	—	—	0	0	0	0	0	0

Bit 7~6 Unimplemented, read as “0”

Bit 5~0 **EEA5~EEA0**: Data EEPROM address bit 5 ~ bit 0

• **EED Register**

Bit	7	6	5	4	3	2	1	0
Name	D7	D6	D5	D4	D3	D2	D1	D0
R/W	R/W	R/W	R/W	R/W	R/W	R/W	R/W	R/W
POR	0	0	0	0	0	0	0	0

Bit 7~0 **D7~D0**: Data EEPROM data bit 7 ~ bit 0

• **EEC Register**

Bit	7	6	5	4	3	2	1	0
Name	—	—	—	—	WREN	WR	RDEN	RD
R/W	—	—	—	—	R/W	R/W	R/W	R/W
POR	—	—	—	—	0	0	0	0

Bit 7~4 Unimplemented, read as “0”

Bit 3 **WREN**: Data EEPROM Write Enable

0: Disable

1: Enable

This is the Data EEPROM Write Enable Bit which must be set high before Data EEPROM write operations are carried out. Clearing this bit to zero will inhibit Data EEPROM write operations.

- Bit 2 **WR:** EEPROM Write Control
 0: Write cycle has finished
 1: Activate a write cycle
This is the Data EEPROM Write Control Bit and when set high by the application program will activate a write cycle. This bit will be automatically reset to zero by the hardware after the write cycle has finished. Setting this bit high will have no effect if the WREN has not first been set high.
- Bit 1 **RDEN:** Data EEPROM Read Enable
 0: Disable
 1: Enable
This is the Data EEPROM Read Enable Bit which must be set high before Data EEPROM read operations are carried out. Clearing this bit to zero will inhibit Data EEPROM read operations.
- Bit 0 **RD:** EEPROM Read Control
 0: Read cycle has finished
 1: Activate a read cycle
This is the Data EEPROM Read Control Bit and when set high by the application program will activate a read cycle. This bit will be automatically reset to zero by the hardware after the read cycle has finished. Setting this bit high will have no effect if the RDEN has not first been set high.

- Note: 1. The WREN, WR, RDEN and RD cannot be set high at the same time in one instruction. The WR and RD cannot be set high at the same time.
2. Ensure that the f_{SUB} clock is stable before executing the write operation.
3. Ensure that the write operation is totally complete before changing the EEC register content.

Reading Data from the EEPROM

To read data from the EEPROM, the EEPROM address of the data to be read must first be placed in the EEA register. The read enable bit, RDEN, in the EEC register must then be set high to enable the read function. If the RD bit in the EEC register is now set high, a read cycle will be initiated. Setting the RD bit high will not initiate a read operation if the RDEN bit has not been set. When the read cycle terminates, the RD bit will be automatically cleared to zero, after which the data can be read from the EED register. The data will remain in the EED register until another read or write operation is executed. The application program can poll the RD bit to determine when the data is valid for reading.

Writing Data to the EEPROM

To write data to the EEPROM, the EEPROM address of the data to be written must first be placed in the EEA register and the data placed in the EED register. To initiate a write cycle the write enable bit, WREN, in the EEC register must first be set high to enable the write function. After this, the WR bit in the EEC register must be immediately set high to initiate a write cycle successfully. These two instructions must be executed in two consecutive instruction cycles. The global interrupt bit EMI should also first be cleared before implementing any write operations, and then set high again after the write cycle has started. Note that setting the WR bit high will not initiate a write cycle if the WREN bit has not been set. As the EEPROM write cycle is controlled using an internal timer whose operation is asynchronous to microcontroller system clock, a certain time will elapse before the data will have been written into the EEPROM. Detecting when the write cycle has finished can be implemented either by polling the WR bit in the EEC register or by using the EEPROM interrupt. When the write cycle terminates, the WR bit will be automatically cleared to zero by the microcontroller, informing the user that the data has been written to the EEPROM. The application program can therefore poll the WR bit to determine when the write cycle has ended.

Write Protection

Protection against inadvertent write operation is provided in several ways. After these devices are powered-on the Write Enable bit in the control register will be cleared preventing any write operations. Also at power-on the Memory Pointer high byte register, MP1H or MP2H, will be reset to zero, which means that Data Memory Sector 0 will be selected. As the EEPROM control register is located in Sector 1, this adds a further measure of protection against spurious write operations. During normal program operation, ensuring that the Write Enable bit in the control register is cleared will safeguard against incorrect write operations.

EEPROM Interrupt

The EEPROM write interrupt is generated when an EEPROM write cycle has ended. The EEPROM interrupt must first be enabled by setting the DEE bit in the relevant interrupt register. When an EEPROM write cycle ends, the DEF request flag will be set. If the global, EEPROM interrupts are enabled and the stack is not full, a jump to the associated EEPROM Interrupt vector will take place. When the interrupt is serviced, the EEPROM Interrupt flag, DEF, will be automatically cleared. The EMI bit will also be automatically cleared to disable other interrupts. More details can be obtained in the Interrupt section.

Programming Considerations

Care must be taken that data is not inadvertently written to the EEPROM. Protection can be enhanced by ensuring that the Write Enable bit is normally cleared to zero when not writing. Also the Memory Pointer high byte register, MP1H or MP2H, could be normally cleared to zero as this would inhibit access to Sector 1 where the EEPROM control register exists. Although certainly not necessary, consideration might be given in the application program to the checking of the validity of new write data by a simple read back process.

When writing data the WR bit must be set high immediately after the WREN bit has been set high, to ensure the write cycle executes correctly. The global interrupt bit EMI should also be cleared before a write cycle is executed and then re-enabled after the write cycle starts. Note that these devices should not enter the IDLE or SLEEP mode until the EEPROM read or write operation is totally complete. Otherwise, the EEPROM read or write operation will fail.

Programming Examples

Reading data from the EEPROM – Polling Method

```
MOV A, EEPROM_ADRES      ; user defined address
MOV EEA, A
MOV A, 040H              ; setup memory pointer MP1L
MOV MP1L, A              ; MP1L points to EEC register
MOV A, 01H               ; setup memory pointer MP1H
MOV MP1H, A
SET IAR1.1               ; set RDEN bit, enable read operations
SET IAR1.0               ; start Read Cycle - set RD bit
BACK:
SZ IAR1.0                ; check for read cycle end
JMP BACK
CLR IAR1                  ; disable EEPROM read if no more read operations are required
CLR MP1H
MOV A, EED                ; move read data to register
MOV READ_DATA, A
```

Note: For each read operation, the address register should be re-specified followed by setting the RD bit high to activate a read cycle even if the target address is consecutive.

Writing Data to the EEPROM – Polling Method

```

MOV A, EEPROM_ADRES      ; user defined address
MOV EEA, A
MOV A, EEPROM_DATA      ; user defined data
MOV EED, A
MOV A, 040H              ; setup memory pointer MP1L
MOV MP1L, A              ; MP1L points to EEC register
MOV A, 01H               ; setup memory pointer MP1H
MOV MP1H, A
CLR EMI
SET IAR1.3               ; set WREN bit, enable write operations
SET IAR1.2               ; start Write Cycle - set WR bit - executed immediately
                          ; after set WREN bit

SET EMI
BACK:
SZ IAR1.2                ; check for write cycle end
JMP BACK
CLR MP1H

```

Oscillators

Various oscillator types offer the user a wide range of functions according to their various application requirements. The flexible features of the oscillator functions ensure that the best optimisation can be achieved in terms of speed and power saving. Oscillator selections and operation are selected through a combination of configuration options and relevant control registers.

Oscillator Overview

In addition to being the source of the main system clock the oscillators also provide clock sources for the Watchdog Timer and Time Base Interrupts. External oscillators requiring some external components as well as fully integrated internal oscillators, requiring no external components, are provided to form a wide range of both fast and slow system oscillators. The higher frequency oscillators provide higher performance but carry with it the disadvantage of higher power requirements, while the opposite is of course true for the lower frequency oscillators. With the capability of dynamically switching between fast and slow system clock, the device has the flexibility to optimize the performance/power ratio, a feature especially important in power sensitive portable applications.

Type	Name	Frequency	Pins
Internal High Speed RC	HIRC	8/12/16MHz	—
Internal Low Speed RC	LIRC	32kHz	—
External Low Speed Crystal ^(Note)	LXT	32.768kHz	XT1/XT2

Note: The external low speed crystal oscillator, LXT, is only available for the BS86E16C/BS86D20C device.

Oscillator Types

System Clock Configurations

There are three methods of generating the system clock, one high speed oscillator and two low speed oscillators. The high speed oscillator is the internal 8/12/16MHz RC oscillator, HIRC. The two low speed oscillators are the internal 32kHz RC oscillator, LIRC, and the external 32.768kHz crystal oscillator, LXT. Selecting whether the low or high speed oscillator is used as the system oscillator is implemented using the HLCLK and CKS2–CKS0 bits in the SMOD register and as the system clock can be dynamically selected.

The actual source clock used for the low speed oscillators is chosen via the corresponding configuration option. The frequency of the slow speed or high speed system clock is determined using the HLCLK and CKS2~CKS0 bits in the SMOD register. Note that two oscillator selections must be made namely one high speed and one low speed system oscillators. It is not possible to choose a no-oscillator selection for either the high or low speed oscillator.

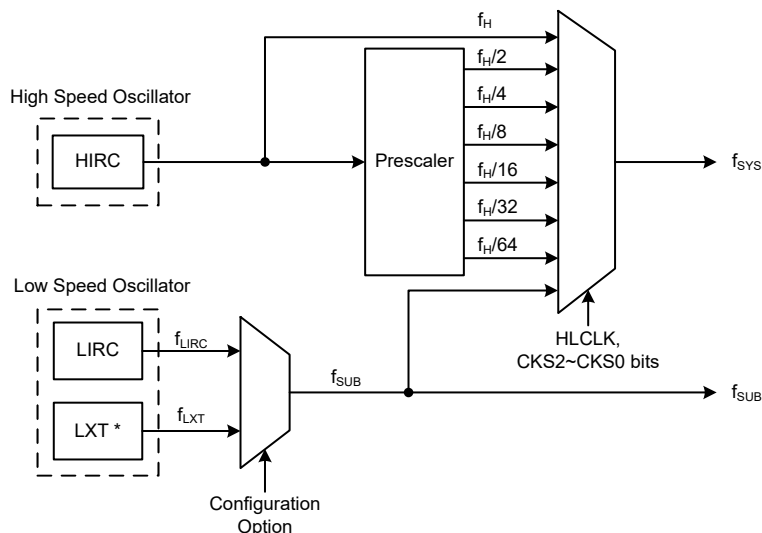

Note: The LXT oscillator is only available for the BS86E16C/BS86D20C device.

System Clock Configurations

Internal High Speed RC Oscillator – HIRC

The internal RC oscillator is a fully integrated system oscillator requiring no external components. The internal RC oscillator has three fixed frequencies of 8MHz, 12MHz and 16MHz, which are selected by the HIRCS1~HIRCS0 bits in the CTRL register. These bits must also be setup to match the selected configuration option frequency to ensure that the HIRC frequency accuracy specified in the A.C. Characteristics is achieved. Device trimming during the manufacturing process and the inclusion of internal frequency compensation circuits are used to ensure that the influence of the power supply voltage, temperature and process variations on the oscillation frequency are minimised. Note that if this internal system clock option is selected, as it requires no external pins for its operation, I/O pins are free for use as normal I/O pins.

Internal 32kHz Oscillator – LIRC

The Internal 32kHz System Oscillator is one of the low frequency oscillator choices, which is selected via a configuration option for the BS86E16C/BS86D20C device. For the BS86C08C/BS86D12C device there is only one low frequency oscillator known as the LIRC oscillator. It is a fully integrated RC oscillator with a typical frequency of 32kHz, requiring no external components for its implementation. Device trimming during the manufacturing process and the inclusion of internal frequency compensation circuits are used to ensure that the influence of the power supply voltage, temperature and process variations on the oscillation frequency are minimised.

External 32.768kHz Crystal Oscillator – LXT (BS86E16C/BS86D20C)

The External 32.768kHz Crystal System Oscillator is one of the low frequency oscillator choices, which is selected via a configuration option. This clock source has a fixed frequency of 32.768kHz and requires a 32.768kHz crystal to be connected between pins XT1 and XT2. The external resistor and capacitor components connected to the 32.768kHz crystal are necessary to provide oscillation. For applications where precise frequencies are essential, these components may be required to provide frequency compensation due to different crystal manufacturing tolerances. During power-up there is a time delay associated with the LXT oscillator waiting for it to start-up.

When the microcontroller enters the SLEEP or IDLE Mode, the system clock is switched off to stop microcontroller activity and to conserve power. However, in many microcontroller applications it may be necessary to keep the internal timers operational even when the microcontroller is in the SLEEP or IDLE Mode. To do this, another clock, independent of the system clock, must be provided.

However, for some crystals, to ensure oscillation and accurate frequency generation, it is necessary to add two small value external capacitors, C1 and C2. The exact values of C1 and C2 should be selected in consultation with the crystal or resonator manufacturer’s specification. The external parallel feedback resistor, R_p, is required.

The configuration option determines if the XT1/XT2 pins are used for the LXT oscillator or as I/O or other pin-shared functions.

- If the LXT oscillator is not used for any clock source, the XT1/XT2 pins can be used as normal I/O or other pin-shared functions.
- If the LXT oscillator is used for any clock source, the 32.768kHz crystal should be connected to the XT1/XT2 pins.

For oscillator stability and to minimise the effects of noise and crosstalk, it is important to ensure that the crystal and any associated resistors and capacitors along with interconnecting lines are all located as close to the MCU as possible.

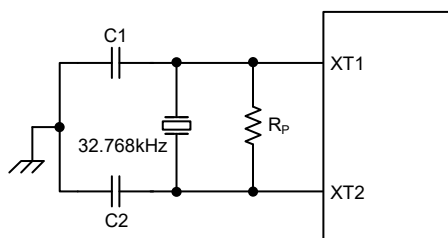

- Note: 1. R_p, C1 and C2 are required.
 2. Although not shown XT1/XT2 pins have a parasitic capacitance of around 7pF.

External LXT Oscillator

LXT Oscillator C1 and C2 Values		
Crystal Frequency	C1	C2
32.768kHz	10pF	10pF
Note: 1. C1 and C2 values are for guidance only. 2. R _p =5M~10MΩ is recommended.		

32.768kHz Crystal Recommended Capacitor Values

LXT Oscillator Low Power Function

The LXT oscillator can function in one of two modes, the Quick Start Mode and the Low Power Mode. The mode selection is executed using the LXTLP bit in the CTRL register.

LXTLP	LXT Operating Mode
0	Quick Start
1	Low Power

After power on, the LXTLP bit will be automatically cleared to zero ensuring that the LXT oscillator is in the Quick Start operating mode. In the Quick Start Mode the LXT oscillator will power up and stabilise quickly. However, after the LXT oscillator has fully powered up it can be placed into the Low-power mode by setting the LXTLP bit high. The oscillator will continue to run but with reduced current consumption, as the higher current consumption is only required during the LXT oscillator start-up. In power sensitive applications, such as battery applications, where power consumption must be kept to a minimum, it is therefore recommended that the application program sets the LXTLP bit high about 2 seconds after power-on.

It should be noted that, no matter what condition the LXTLP bit is set to, the LXT oscillator will always function normally. The only difference is that it will take more time to start up if in the Low-power mode.

Operating Modes and System Clocks

Present day applications require that their microcontrollers have high performance but often still demand that they consume as little power as possible, conflicting requirements that are especially true in battery powered portable applications. The fast clocks required for high performance will by their nature increase current consumption and of course vice-versa lower speed clocks reduce current consumption. As Holtek has provided these devices with both high and low speed clock sources and the means to switch between them dynamically, the user can optimise the operation of their microcontroller to achieve the best performance/power ratio.

System Clocks

Each device has different clock sources for both the CPU and peripheral function operation. By providing the user with a wide range of clock selections using register programming, a clock system can be configured to obtain maximum application performance.

The main system clock, can come from either a high frequency, f_H , or low frequency, f_{SUB} , source, and is selected using the HLCLK bit and CKS2~CKS0 bits in the SMOD register. The high speed system clock is sourced from the HIRC oscillator. The low speed system clock source can be sourced from the internal clock f_{SUB} . If f_{SUB} is selected then it can be sourced by either the LXT or LIRC oscillators, selected via a configuration option. The other choice, which is a divided version of the high speed system oscillator has a range of $f_H/2 \sim f_H/64$.

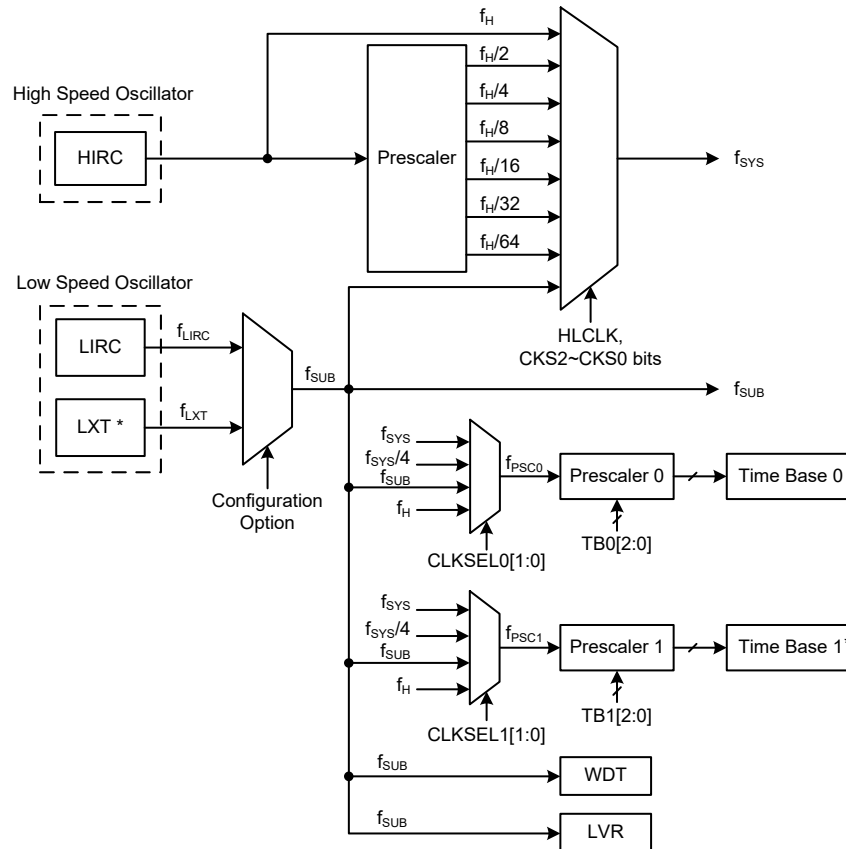

Device Clock Configurations

- Note: 1. The LXT oscillator and Time Base 1 are only available for the BS86E16C/BS86D20C device.
 2. When the system clock source f_{SYS} is switched to f_{SUB} from f_H , the high speed oscillation will stop to conserve the power. Thus there is no $f_H \sim f_H/64$ for peripheral circuit to use.

System Operation Modes

There are five different modes of operation for the microcontroller, each one with its own special characteristics and which can be chosen according to the specific performance and power requirements of the application. There are two modes allowing normal operation of the microcontroller, the FAST Mode and SLOW Mode. The remaining three modes, the SLEEP, IDLE0 and IDLE1 Mode are used when the microcontroller CPU is switched off to conserve power.

Operation Mode	CPU	f_{SYS}	f_{SUB}
FAST	On	$f_H \sim f_H/64$	On
SLOW	On	f_{SUB}	On
IDLE0	Off	Off	On
IDLE1	Off	On	On
SLEEP	Off	Off	On

FAST Mode

This is one of the main operating modes where the microcontroller has all of its functions operational and where the system clock is provided by the high speed oscillator. This mode operates allowing the microcontroller to operate normally with a clock source will come from the high speed oscillator, HIRC. The high speed oscillator will however first be divided by a ratio ranging from 1 to 64, the actual ratio being selected by the CKS2~CKS0 and HLCLK bits in the SMOD register. Although a high speed oscillator is used, running the microcontroller at a divided clock ratio reduces the operating current.

SLOW Mode

This is also a mode where the microcontroller operates normally although now with a slower speed clock source. The clock source used will be from f_{SUB} . The f_{SUB} clock is derived from either the LIRC or LXT oscillator for the BS86E16C/BS86D20C device while the f_{SUB} clock is from the LIRC oscillator for the BS86C08C/BS86D12C device. Running the microcontroller in this mode allow it to run with much lower operating currents. In the SLOW Mode, the f_H is off.

SLEEP Mode

The SLEEP Mode is entered when an HALT instruction is executed and when the IDLEN bit in the SMOD register is low. In the SLEEP mode the CPU will be stopped and both the high and low speed oscillators will be switched off. However the f_{SUB} clock will continue to operate as the WDT function is always enabled.

IDLE0 Mode

The IDLE0 Mode is entered when an HALT instruction is executed and when the IDLEN bit in the SMOD register is high and the FSYSON bit in the CTRL register is low. In the IDLE0 Mode the system oscillator will be switched off and therefore will be inhibited from driving the CPU but some peripheral functions will remain operational. In the IDLE0 Mode, the system oscillator will be stopped.

IDLE1 Mode

The IDLE1 Mode is entered when an HALT instruction is executed and when the IDLEN bit in the SMOD register is high and the FSYSON bit in the CTRL register is high. In the IDLE1 Mode the system oscillator will be inhibited from driving the CPU but may continue to provide a clock source to keep some peripheral functions operational. In the IDLE1 Mode, the system oscillator will continue to run and this system oscillator may be the high speed or low speed oscillator.

Control Registers

The registers, SMOD and CTRL, are used to control the internal clocks within the devices.

Register Name	Bit							
	7	6	5	4	3	2	1	0
SMOD	CKS2	CKS1	CKS0	—	LTO	HTO	IDLEN	HLCLK
CTRL (BS86C08C/ BS86D12C)	FSYSON	—	HIRCS1	HIRCS0	—	LVRF	LRF	WRF
CTRL (BS86E16C/ BS86D20C)	FSYSON	—	HIRCS1	HIRCS0	LXTLP	LVRF	LRF	WRF

System Operating Mode Control Register List

• **SMOD Register**

Bit	7	6	5	4	3	2	1	0
Name	CKS2	CKS1	CKS0	—	LTO	HTO	IDLEN	HLCLK
R/W	R/W	R/W	R/W	—	R	R	R/W	R/W
POR	0	0	0	—	0	0	1	1

Bit 7~5 **CKS2~CKS0:** System clock selection when HLCLK is “0”

- 000: f_{SUB} (LIRC or LXT)
- 001: f_{SUB} (LIRC or LXT)
- 010: $f_H/64$
- 011: $f_H/32$
- 100: $f_H/16$
- 101: $f_H/8$
- 110: $f_H/4$
- 111: $f_H/2$

These three bits are used to select which clock is used as the system clock source. In addition to the system clock source, which can be either the LXT or LIRC, a divided version of the high speed system oscillator can also be chosen as the system clock source.

Note that the LXT oscillator is only available for the BS86E16C/BS86D20C device.

Bit 4 Unimplemented, read as “0”

Bit 3 **LTO:** Low speed system oscillator ready flag

- 0: Not ready
- 1: Ready

This is the low speed system oscillator ready flag which indicates when the low speed system oscillator is stable after power on reset or a wake-up has occurred. The flag will be low when in the SLEEP Mode but after a wake-up has occurred, the flag will change to a high level after 128 clock cycles if LXT oscillator is used and 1~2 clock cycles if the LIRC oscillator is used.

Bit 2 **HTO:** High speed system oscillator ready flag

- 0: Not ready
- 1: Ready

This is the high speed system oscillator ready flag which indicates when the high speed system oscillator is stable after a wake-up has occurred. This flag is cleared to zero by hardware when the device is powered on and then changes to a high level after the high speed system oscillator is stable. Therefore, this flag will always be read as “1” by the application program after device power-on. The flag will be low when in the SLEEP or IDLE0 Mode but after power on reset or a wake-up has occurred, the flag will change to a high level after 15~16 clock cycles if the HIRC oscillator is used.

Bit 1 **IDLEN:** IDLE Mode Control

- 0: Disable
- 1: Enable

This bit is the IDLE Mode control bit and determines what happens when the HALT instruction is executed. If this bit is high, when a HALT instruction is executed the device will enter the IDLE Mode. In the IDLE1 Mode the CPU will stop running but the system clock will continue to keep the peripheral functions operational, if FSYSON bit is high. If the FSYSON bit is low, the CPU and the system clock will all stop in the IDLE0 Mode. If the bit is low the device will enter the SLEEP Mode when a HALT instruction is executed.

Bit 0 **HLCLK:** System clock selection

- 0: $f_H/2$ ~ $f_H/64$ or f_{SUB}
- 1: f_H

This bit is used to select if the f_H clock, the $f_H/2$ ~ $f_H/64$ or f_{SUB} clock is used as the system clock. When this bit is high the f_H clock will be selected and if low the $f_H/2$ ~ $f_H/64$ or f_{SUB} clock will be selected. When the system clock is switched from the f_H clock to the f_{SUB} clock, the f_H clock will automatically be switched off to conserve power.

• CTRL Register – BS86C08C/BS86D12C

Bit	7	6	5	4	3	2	1	0
Name	FSYSON	—	HIRCS1	HIRCS0	—	LVRF	LRF	WRF
R/W	R/W	—	R/W	R/W	—	R/W	R/W	R/W
POR	0	—	0	0	—	x	0	0

“x”: unknown

• CTRL Register – BS86E16C/BS86D20C

Bit	7	6	5	4	3	2	1	0
Name	FSYSON	—	HIRCS1	HIRCS0	LXTLP	LVRF	LRF	WRF
R/W	R/W	—	R/W	R/W	R/W	R/W	R/W	R/W
POR	0	—	0	0	0	x	0	0

“x”: unknown

Bit 7 **FSYSON**: f_{sys} Control in IDLE Mode
 0: Disable
 1: Enable

Bit 6 Unimplemented, read as “0”

Bit 5~4 **HIRCS1~HIRCS0**: HIRC frequency selection
 00: 8MHz
 01: 12MHz
 10: 16MHz
 11: 8MHz

It is recommended that the HIRC frequency selected by these two bits should be the same with the frequency determined by the configuration option to achieve the HIRC frequency accuracy specified in the A.C. characteristics.

Bit 3 **LXTLP**: LXT low power control
 0: Quick Start mode
 1: Low Power mode

Note that this bit is used to select the operating mode of the LXT oscillator which is only available for the BS86E16C/BS86D20C device. For the BS86C08C/BS86D12C device this bit is unimplemented and is read as “0”.

Bit 2 **LVRF**: LVR function reset flag
 Described elsewhere

Bit 1 **LRF**: LVR control register software reset flag
 Described elsewhere

Bit 0 **WRF**: WDT control register software reset flag
 Described elsewhere

Operating Mode Switching

These devices can switch between operating modes dynamically allowing the user to select the best performance/power ratio for the present task in hand. In this way microcontroller operations that do not require high performance can be executed using slower clocks thus requiring less operating current and prolonging battery life in portable applications.

In simple terms, Mode Switching between the FAST Mode and SLOW Mode is executed using the HLCLK and CKS2~CKS0 bits in the SMOD register while Mode Switching from the FAST/SLOW Modes to the SLEEP/IDLE Modes is executed via the HALT instruction. When an HALT instruction is executed, whether the device enters the IDLE Mode or the SLEEP Mode is determined by the condition of the IDLEN bit in the SMOD register and the FSYSON bit in the CTRL register.

When the HLCLK bit switches to a low level, which implies that clock source is switched from the high speed clock source, f_H , to the clock source, $f_H/2 \sim f_H/64$ or f_{SUB} . If the clock is from the f_{SUB} , the high speed clock source will stop running to conserve power. When this happens it must be noted that the $f_H/16$ and $f_H/64$ internal clock sources will also stop running. The accompanying flowchart shows what happens when the device moves between the various operating modes.

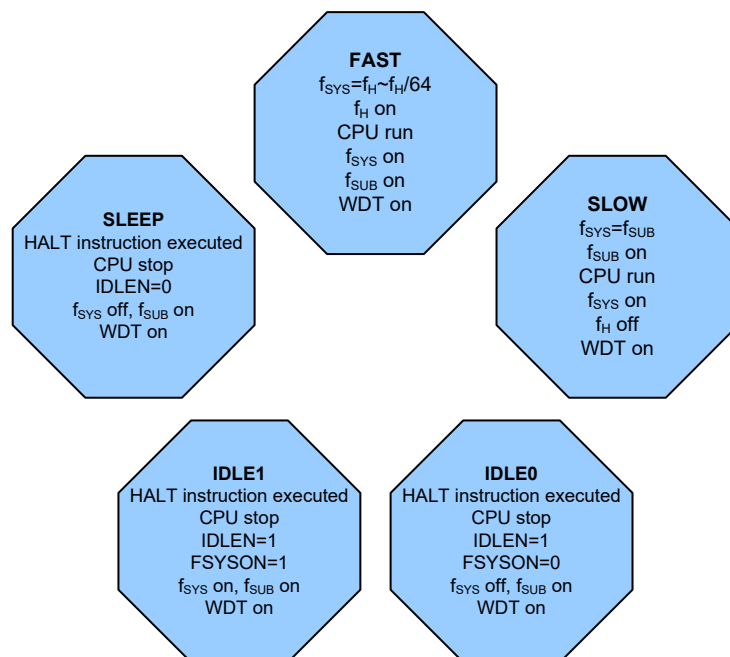

FAST Mode to SLOW Mode Switching

When running in the FAST Mode, which uses the high speed system oscillator, and therefore consumes more power, the system clock can switch to run in the SLOW Mode by clearing the HLCLK bit to zero and setting the CKS2~CKS0 bits to “000” or “001” in the SMOD register. This will then use the low speed system oscillator which will consume less power. Users may decide to do this for certain operations which do not require high performance and can subsequently reduce power consumption.

The SLOW Mode is sourced from the LXT or LIRC oscillator and therefore requires the specific oscillator to stable before full mode switching occurs.

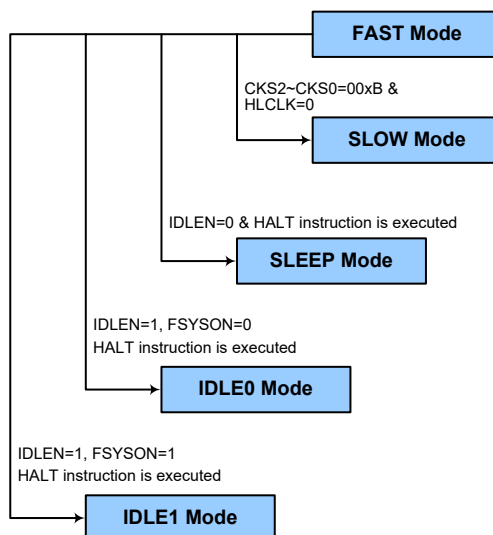

SLOW Mode to FAST Mode Switching

In SLOW mode the system uses the f_{SUB} clock derived from either the LXT or LIRC low speed oscillator as system clock. When system clock is switched back to the FAST mode from f_{SUB} , where the high speed system oscillator is used, the HLCLK bit should be set high or HLCLK bit is low but the CKS2~CKS0 bits are set to “010~111” and then the system clock will respectively be switched to $f_H \sim f_H/64$.

However, if f_H is not used in SLOW mode and thus switched off, it will take some time to re-oscillate and stabilise when switching back to the FAST mode from the SLOW Mode and the status of the HTO flag should be checked. The time duration required for the high speed system oscillator stabilization is specified in the relevant characteristics.

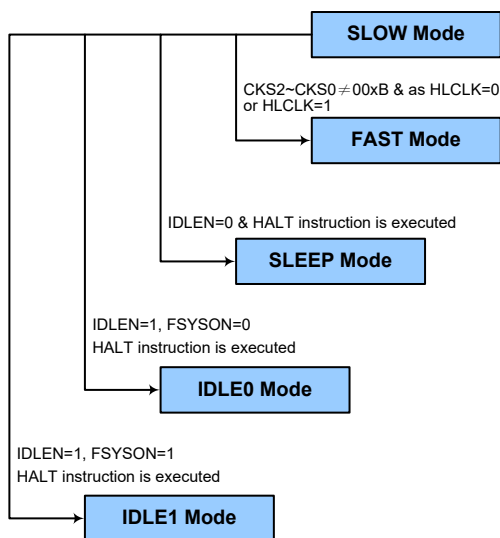

Entering the SLEEP Mode

There is only one way for the device to enter the SLEEP Mode and that is to execute the “HALT” instruction in the application program with the IDLEN bit in the SMOD register equal to “0”. In this mode all the clocks and functions will be switched off except the WDT function. When this instruction is executed under the conditions described above, the following will occur:

- The system clock will be stopped and the application program will stop at the “HALT” instruction.
- The Data Memory contents and registers will maintain their present condition.
- The I/O ports will maintain their present conditions.
- In the status register, the Power Down flag PDF will be set, and WDT timeout flag TO will be cleared.
- The WDT will be cleared and resume counting as the WDT function is always enabled.

Entering the IDLE0 Mode

There is only one way for the device to enter the IDLE0 Mode and that is to execute the “HALT” instruction in the application program with the IDLEN bit in the SMOD register equal to “1” and the FSYSON bit in the CTRL register equal to “0”. When this instruction is executed under the conditions described above, the following will occur:

- The system clock will be stopped and the application program will stop at the “HALT” instruction, but the low frequency clock f_{SUB} will be on.
- The Data Memory contents and registers will maintain their present condition.
- The I/O ports will maintain their present conditions.
- In the status register, the Power Down flag PDF will be set, and WDT timeout flag TO will be cleared.
- The WDT will be cleared and resume counting.

Entering the IDLE1 Mode

There is only one way for the device to enter the IDLE1 Mode and that is to execute the “HALT” instruction in the application program with the IDLEN bit in the SMOD register is equal to “1” and the FSYSON bit in the CTRL register equal to “1”. When this instruction is executed under the conditions described above, the following will occur:

- The system and the low frequency f_{SUB} clocks will be on but the application program will stop at the “HALT” instruction.
- The Data Memory contents and registers will maintain their present condition.
- The I/O ports will maintain their present conditions.
- In the status register, the Power Down flag PDF will be set, and WDT timeout flag TO will be cleared.
- The WDT will be cleared and resume counting.

Standby Current Considerations

As the main reason for entering the SLEEP or IDLE Mode is to keep the current consumption of the device to as low a value as possible, perhaps only in the order of several micro-amps except in the IDLE1 Mode, there are other considerations which must also be taken into account by the circuit designer if the power consumption is to be minimised. Special attention must be made to the I/O pins on the device. All high-impedance input pins must be connected to either a fixed high or low level as any floating input pins could create internal oscillations and result in increased current consumption. This also applies to devices which have different package types, as there may be unbonded pins. These must either be setup as outputs or if setup as inputs must have pull-high resistors connected.

Care must also be taken with the loads, which are connected to I/O pins, which are setup as outputs. These should be placed in a condition in which minimum current is drawn or connected only to external circuits that do not draw current, such as other CMOS inputs. Also note that additional standby current will also be consumed if the LIRC or LXT oscillator has enabled.

In the IDLE1 Mode the system oscillator is on, if the peripheral function clock source is derived from the high speed oscillator, the additional standby current will also be perhaps in the order of several hundred micro-amps.

Wake-up

To minimise power consumption the device can enter the SLEEP or any IDLE Mode, where the CPU will be switched off. However, when the device is woken up again, it will take a considerable time for the original system oscillator to restart, stabilise and allow normal operation to resume.

After the system enters the SLEEP or IDLE Mode, it can be woken up from one of various sources listed as follows:

- An external falling edge on Port A
- A system interrupt
- A WDT overflow

When the device executes the “HALT” instruction, the PDF flag will be set to 1. The PDF flag will be cleared to 0 if the device experiences a system power-up or executes the clear Watchdog Timer instruction. If the system is woken up by a WDT overflow, a Watchdog Timer reset will be initiated and the TO flag will be set to 1. The TO flag is set if a WDT time-out occurs and causes a wake-up that only resets the Program Counter and Stack Pointer, other flags remain in their original status.

Each pin on Port A can be setup using the PAWU register to permit a negative transition on the pin to wake up the system. When a Port A pin wake-up occurs, the program will resume execution at the instruction following the “HALT” instruction. If the system is woken up by an interrupt, then two possible situations may occur. The first is where the related interrupt is disabled or the interrupt is enabled but the stack is full, in which case the program will resume execution at the instruction following the “HALT” instruction. In this situation, the interrupt which woke up the device will not be immediately serviced, but will rather be serviced later when the related interrupt is finally enabled or when a stack level becomes free. The other situation is where the related interrupt is enabled and the stack is not full, in which case the regular interrupt response takes place. If an interrupt request flag is set high before entering the SLEEP or IDLE Mode, the wake-up function of the related interrupt will be disabled.

System Oscillator	Wake-up Time (SLEEP Mode)	Wake-up Time (IDLE0 Mode)	Wake-up Time (IDLE1 Mode)
HIRC	15~16 HIRC cycles		1~2 HIRC cycles
LIRC	1~2 LIRC cycles		1~2 LIRC cycles
LXT ^(Note)	128 LXT cycles		1~2 LXT cycles

Note: The LXT oscillator is only available for the BS86E16C/BS86D20C device.

Wake-up Time

Programming Considerations

The high speed and low speed oscillators both use the same SST counter. For example, if the system is woken up from the SLEEP Mode the HIRC oscillator needs to start-up from an off state. If the device is woken up from the SLEEP Mode to the FAST Mode, the high speed system oscillator needs an SST period. The device will execute the first instruction after HTO is high. At this time, the LXT oscillator may not be stability if f_{SUB} is from LXT oscillator. The same situation occurs in the power-on state. The LXT oscillator is not ready yet when the first instruction is executed.

Watchdog Timer

The Watchdog Timer is provided to prevent program malfunctions or sequences from jumping to unknown locations, due to certain uncontrollable external events such as electrical noise.

Watchdog Timer Clock Source

The Watchdog Timer clock source is provided by the internal f_{SUB} clock which is in turn supplied by either the LXT or LIRC oscillator selected by a configuration option. The LIRC internal oscillator has an approximate frequency of 32kHz and this specified internal clock period can vary with V_{DD} , temperature and process variations. The LXT oscillator is supplied by an external 32.768kHz crystal. The Watchdog Timer source clock is then subdivided by a ratio of 2^8 to 2^{18} to give longer timeouts, the actual value being chosen using the WS2~WS0 bits in the WDTC register.

Watchdog Timer Control Register

A single register, WDTC, controls the required timeout period as well as the enable/reset control. This register controls the overall operation of the Watchdog Timer. The WDTC register is initiated to 01010011B at any reset except the WDT time-out hardware warm reset.

• WDTC Register

Bit	7	6	5	4	3	2	1	0
Name	WE4	WE3	WE2	WE1	WE0	WS2	WS1	WS0
R/W	R/W	R/W	R/W	R/W	R/W	R/W	R/W	R/W
POR	0	1	0	1	0	0	1	1

Bit 7~3 **WE4~WE0:** WDT function control
 01010 or 10101: Enable
 Other values: Reset MCU

If these bits are changed due to adverse environmental conditions, the microcontroller will be reset. The reset operation will be activated after a delay time, t_{SRESET} , and the WRF bit in the CTRL register will be set high.

Bit 2~0 **WS2~WS0:** WDT time-out period selection
 000: $2^8/f_{SUB}$
 001: $2^{10}/f_{SUB}$
 010: $2^{12}/f_{SUB}$
 011: $2^{14}/f_{SUB}$
 100: $2^{15}/f_{SUB}$
 101: $2^{16}/f_{SUB}$
 110: $2^{17}/f_{SUB}$
 111: $2^{18}/f_{SUB}$

These three bits determine the division ratio of the watchdog timer source clock, which in turn determines the time-out period.

• CTRL Register – BS86C08C/BS86D12C

Bit	7	6	5	4	3	2	1	0
Name	FSYSON	—	HIRCS1	HIRCS0	—	LVRF	LRF	WRF
R/W	R/W	—	R/W	R/W	—	R/W	R/W	R/W
POR	0	—	0	0	—	x	0	0

“x”: unknown

• **CTRL Register – BS86E16C/BS86D20C**

Bit	7	6	5	4	3	2	1	0
Name	FSYSON	—	HIRCS1	HIRCS0	LXTLP	LVRF	LRF	WRF
R/W	R/W	—	R/W	R/W	R/W	R/W	R/W	R/W
POR	0	—	0	0	0	x	0	0

“x”: unknown

- Bit 7 **FSYSON**: f_{sys} Control in IDLE Mode
Described elsewhere
- Bit 6 Unimplemented, read as “0”
- Bit 5~4 **HIRCS1~HIRCS0**: HIRC frequency selection
Described elsewhere
- Bit 3 **LXTLP**: LXT low power control
Described elsewhere
- Bit 2 **LVRF**: LVR function reset flag
Described elsewhere
- Bit 1 **LRF**: LVR control register software reset flag
Described elsewhere
- Bit 0 **WRF**: WDT control register software reset flag
0: Not occur
1: Occurred

This bit is set high by the WDT control register software reset and cleared by the application program. Note that this bit can only be cleared to zero by the application program.

Watchdog Timer Operation

The Watchdog Timer operates by providing a device reset when its timer overflows. This means that in the application program and during normal operation the user has to strategically clear the Watchdog Timer before it overflows to prevent the Watchdog Timer from executing a reset. This is done using the clear watchdog instruction. If the program malfunctions for whatever reason, jumps to an unknown location, or enters an endless loop, the clear instruction will not be executed in the correct manner, in which case the Watchdog Timer will overflow and reset the device. With regard to the Watchdog Timer function control, there are five bits, WE4~WE0, in the WDTC register to offer the enable and reset control of the Watchdog Timer. The WDT function will be enabled when the WE4~WE0 bits are set to a value of 01010B or 10101B. If the WE4~WE0 bits are changed to any other values rather than 01010B and 10101B, which is caused by the environmental noise, it will reset the device after a delay time, t_{RESET}. After power on these bits will have a value of 01010B.

WE4~WE0 Bits	WDT Function
01010B or 10101B	Enable
Any other value	Reset MCU

Watchdog Timer Enable/Reset Control

Under normal program operation, a Watchdog Timer time-out will initialise a device reset and set the status bit TO. However, if the system is in the SLEEP or IDLE Mode, when a Watchdog Timer time-out occurs, the TO bit in the status register will be set and only the Program Counter and Stack Pointer will be reset. Three methods can be adopted to clear the contents of the Watchdog Timer. The first is a WDTC software reset, which means a certain value except 01010B and 10101B written into the WE4~WE0 field, the second is using the Watchdog Timer software clear instruction and the third is via a HALT instruction.

There is only one method of using software instruction to clear the Watchdog Timer. That is to use the single “CLR WDT” instruction to clear the WDT contents.

The maximum time out period is when the 2^{18} division ratio is selected. As an example, with a 32kHz LIRC oscillator as its source clock, this will give a maximum watchdog period of around 8 second for the 2^{18} division ratio and a minimum timeout of 8ms for the 2^8 division ratio.

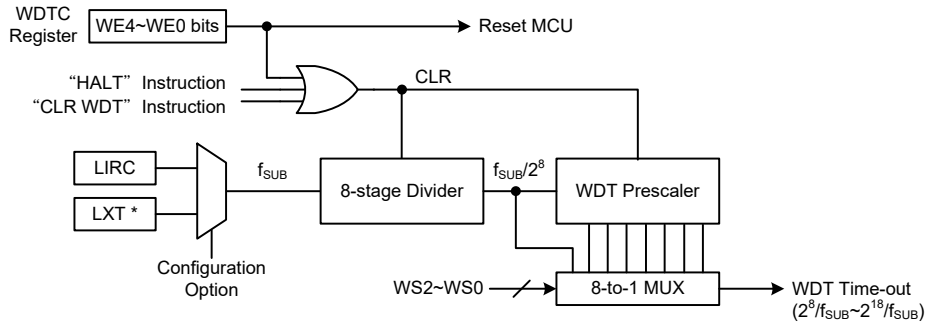

Note: The LXT oscillator is only available for the BS86E16C/BS86D20C device.

Watchdog Timer

Reset and Initialisation

A reset function is a fundamental part of any microcontroller ensuring that the device can be set to some predetermined condition irrespective of outside parameters. The most important reset condition is after power is first applied to the microcontroller. In this case, internal circuitry will ensure that the microcontroller, after a short delay, will be in a well-defined state and ready to execute the first program instruction. After this power-on reset, certain important internal registers will be set to defined states before the program commences. One of these registers is the Program Counter, which will be reset to zero forcing the microcontroller to begin program execution from the lowest Program Memory address.

In addition to the power-on reset, another reset exists in the form of a Low Voltage Reset, LVR, where a full reset is implemented in situations where the power supply voltage falls below a certain threshold. Another type of reset is when the Watchdog Timer overflows and resets the microcontroller. All types of reset operations result in different register conditions being setup.

Reset Functions

There are several ways in which a microcontroller reset can occur, through events occurring internally.

Power-on Reset

The most fundamental and unavoidable reset is the one that occurs after power is first applied to the microcontroller. As well as ensuring that the Program Memory begins execution from the first memory address, a power-on reset also ensures that certain other registers are preset to known conditions. All the I/O port and port control registers will power up in a high condition ensuring that all pins will be first set to inputs.

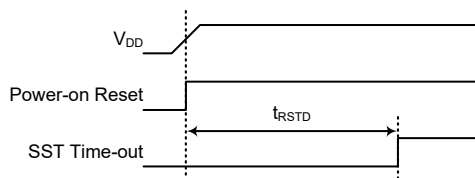

Note: t_{RSTD} is power-on delay with typical time=48ms

Power-On Reset Timing Chart

Low Voltage Reset – LVR

The microcontrollers contain a low voltage reset circuit in order to monitor the supply voltage of the devices. The LVR function is always enabled in the Fast or Slow mode with a specific LVR voltage, V_{LVR} . If the supply voltage of the devices drops to within a range of $0.9V \sim V_{LVR}$ such as might occur when changing the battery, the LVR will automatically reset the devices internally and the LVRF bit in the CTRL register will also be set to 1. For a valid LVR signal, a low supply voltage, i.e., a voltage in the range between $0.9V \sim V_{LVR}$ must exist for a time greater than that specified by t_{LVR} in the LVD/LVR Electrical Characteristics. If the low supply voltage state does not exceed this value, the LVR will ignore the low supply voltage and will not perform a reset function. The actual V_{LVR} value can be selected by the LVS bits in the LVRC register. If the LVS7~LVS0 bits have any other value, which may perhaps occur due to adverse environmental conditions such as noise, the LVR will reset the devices after a delay time, t_{SRESET} . When this happens, the LRF bit in the CTRL register will be set to 1. After power on the register will have the default value of 01010101B. Note that the LVR function will be automatically disabled when the devices enter the SLEEP/IDLE mode.

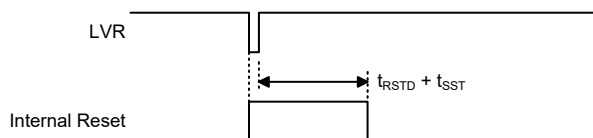

Note: t_{RSTD} is power-on delay with typical time=48ms

Low Voltage Reset Timing Chart

• LVRC Register

Bit	7	6	5	4	3	2	1	0
Name	LVS7	LVS6	LVS5	LVS4	LVS3	LVS2	LVS1	LVS0
R/W	R/W	R/W	R/W	R/W	R/W	R/W	R/W	R/W
POR	0	1	0	1	0	1	0	1

Bit 7~0 **LVS7~LVS0:** LVR voltage select

01010101: 2.1V

00110011: 2.55V

10011001: 3.15V

10101010: 3.8V

Other values: Generates a MCU reset – register is reset to POR value

When an actual low voltage condition occurs, as specified by the LVR voltage value above, an MCU reset will be generated. The reset operation will be activated after the low voltage condition keeps for greater than a t_{LVR} time.

Any register value, other than the four defined register values above, will also result in the generation of an MCU reset. The reset operation will be activated after a delay time, t_{SRESET} . However in this situation the register contents will be reset to the POR value.

• CTRL Register – BS86C08C/BS86D12C

Bit	7	6	5	4	3	2	1	0
Name	FSYSON	—	HIRCS1	HIRCS0	—	LVRF	LRF	WRF
R/W	R/W	—	R/W	R/W	—	R/W	R/W	R/W
POR	0	—	0	0	—	x	0	0

“x”: unknown

• CTRL Register – BS86E16C/BS86D20C

Bit	7	6	5	4	3	2	1	0
Name	FSYSON	—	HIRCS1	HIRCS0	LXTLP	LVRF	LRF	WRF
R/W	R/W	—	R/W	R/W	R/W	R/W	R/W	R/W
POR	0	—	0	0	0	x	0	0

“x”: unknown

- Bit 7 **FSYSON**: f_{sys} Control in IDLE Mode
Described elsewhere
- Bit 6 Unimplemented, read as “0”
- Bit 5~4 **HIRCS1~HIRCS0**: HIRC frequency selection
Described elsewhere
- Bit 3 **LXTLP**: LXT low power control
Described elsewhere
- Bit 2 **LVRF**: LVR function reset flag
0: Not occurred
1: Occurred
This bit is set to 1 when a specific low voltage reset condition occurs. Note that this bit can only be cleared to 0 by the application program.
- Bit 1 **LRF**: LVR control register software reset flag
0: Not occurred
1: Occurred
This bit is set to 1 by the LVRC control register contains any undefined LVR voltage register values. This in effect acts like a software-reset function. Note that this bit can only be cleared to 0 by the application program.
- Bit 0 **WRF**: WDT control register software reset flag
Described elsewhere

Watchdog Time-out Reset during Normal Operation

The Watchdog time-out Reset during normal operations in the FAST or SLOW mode is the same as the hardware Low Voltage Reset except that the Watchdog time-out flag TO will be set to “1”.

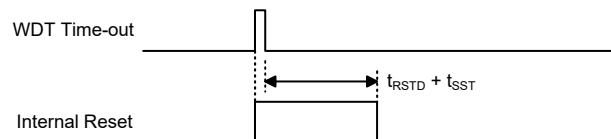

Note: t_{RSTD} is power-on delay with typical time=16ms

WDT Time-out Reset during Normal Operation Timing Chart

Watchdog Time-out Reset during SLEEP or IDLE Mode

The Watchdog time-out Reset during SLEEP or IDLE Mode is a little different from other kinds of reset. Most of the conditions remain unchanged except that the Program Counter and the Stack Pointer will be cleared to “0” and the TO flag will be set to “1”. Refer to the System Start Up Time Characteristics for t_{SST} details.

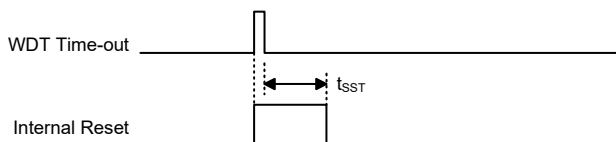

WDT Time-out Reset during SLEEP or IDLE Mode Timing Chart

Reset Initial Conditions

The different types of reset described affect the reset flags in different ways. These flags, known as PDF and TO are located in the status register and are controlled by various microcontroller operations, such as the SLEEP or IDLE Mode function or Watchdog Timer. The reset flags are shown in the table:

TO	PDF	Reset Conditions
0	0	Power-on reset
u	u	LVR reset during FAST or SLOW Mode operation
1	u	WDT time-out reset during FAST or SLOW Mode operation
1	1	WDT time-out reset during IDLE or SLEEP Mode operation

“u” stands for unchanged

The following table indicates the way in which the various components of the microcontroller are affected after a power-on reset occurs.

Item	Condition after Reset
Program Counter	Reset to zero
Interrupts	All interrupts will be disabled
WDT, Time Bases	Clear after reset, WDT begins counting
Timer Modules	Timer Modules will be turned off
Input/Output Ports	I/O ports will be setup as inputs
Stack Pointer	Stack Pointer will point to the top of the stack

The different kinds of resets all affect the internal registers of the microcontroller in different ways. To ensure reliable continuation of normal program execution after a reset occurs, it is important to know what condition the microcontroller is in after a particular reset occurs. The following table describes how each type of reset affects the microcontroller internal registers. Note that where more than one package type exists the table will reflect the situation for the larger package type.

Register	BS86C08C	BS86D12C	BS86E16C	BS86D20C	Power On Reset	LVR Reset (Normal Operation)	WDT Time-out (Normal Operation)	WDT Time-out (IDLE/SLEEP)
IAR0	•	•	•	•	0000 0000	0000 0000	0000 0000	uuuu uuuu
MP0	•	•	•	•	0000 0000	0000 0000	0000 0000	uuuu uuuu
IAR1	•	•	•	•	0000 0000	0000 0000	0000 0000	uuuu uuuu
MP1L	•	•	•	•	0000 0000	0000 0000	0000 0000	uuuu uuuu
MP1H	•	•	•	•	0000 0000	0000 0000	0000 0000	uuuu uuuu
ACC	•	•	•	•	xxxx xxxx	uuuu uuuu	uuuu uuuu	uuuu uuuu
PCL	•	•	•	•	0000 0000	0000 0000	0000 0000	0000 0000
TBLP	•	•	•	•	xxxx xxxx	uuuu uuuu	uuuu uuuu	uuuu uuuu
TBLH	•	•	•	•	xxxx xxxx	uuuu uuuu	uuuu uuuu	uuuu uuuu
TBHP	•				--- xxxx	--- uuuu	--- uuuu	--- uuuu
		•		•	---x xxxx	---u uuuu	---u uuuu	---u uuuu
			•		--xx xxxx	--uu uuuu	--uu uuuu	--uu uuuu

Register	BS86C08C	BS86D12C	BS86E16C	BS86D20C	Power On Reset	LVR Reset (Normal Operation)	WDT Time-out (Normal Operation)	WDT Time-out (IDLE/SLEEP)
STATUS	•	•	•	•	xx00 xxxx	uuuu uuuu	uu1u uuuu	uu11 uuuu
SMOD	•	•	•	•	000- 0011	000- 0011	000- 0011	uuu- uuuu
PBP			•		---- --0	---- --0	---- --0	---- --u
IAR2	•	•	•	•	0000 0000	0000 0000	0000 0000	uuuu uuuu
MP2L	•	•	•	•	0000 0000	0000 0000	0000 0000	uuuu uuuu
MP2H	•	•	•	•	0000 0000	0000 0000	0000 0000	uuuu uuuu
INTEG	•	•	•	•	---- --00	---- --00	---- --00	---- --uu
INTC0	•	•	•	•	-000 0000	-000 0000	-000 0000	-uuu uuuu
INTC1	•	•	•	•	0000 0000	0000 0000	0000 0000	uuuu uuuu
INTC2	•	•	•	•	0000 0000	0000 0000	0000 0000	uuuu uuuu
INTC3	•	•			---0 --0	---0 --0	---0 --0	---u ---u
			•		0000 0000	0000 0000	0000 0000	uuuu uuuu
				•	0-00 00-0	0-00 00-0	0-00 00-0	u-uu uu-u
PA	•	•	•	•	1--1 1111	1--1 1111	1--1 1111	u--u uuuu
PAC	•	•	•	•	1--1 1111	1--1 1111	1--1 1111	u--u uuuu
PAPU	•	•	•	•	0--0 0000	0--0 0000	0--0 0000	u--u uuuu
PAWU	•	•	•	•	0--0 0000	0--0 0000	0--0 0000	u--u uuuu
SLEDC0	•	•	•	•	0101 0101	0101 0101	0101 0101	uuuu uuuu
SLEDC1	•	•			0101 --01	0101 --01	0101 --01	uuuu --uu
			•		0101 0101	0101 0101	0101 0101	uuuu uuuu
				•	--01 0101	--01 0101	--01 0101	--uu uuuu
WDTC	•	•	•	•	0101 0011	0101 0011	0101 0011	uuuu uuuu
TBC	•	•			---- 0000	---- 0000	---- 0000	---- uuuu
			•	•	0000 0000	0000 0000	0000 0000	uuuu uuuu
PSCR	•	•			---- --00	---- --00	---- --00	---- --uu
			•	•	--00 --00	--00 --00	--00 --00	--uu --uu
LVRC	•	•	•	•	0101 0101	0101 0101	0101 0101	uuuu uuuu
EEA	•				--0 0000	--0 0000	--0 0000	--u uuuu
		•	•	•	--00 0000	--00 0000	--00 0000	--uu uuuu
EED	•	•	•	•	0000 0000	0000 0000	0000 0000	uuuu uuuu
PB	•	•	•	•	1111 1111	1111 1111	1111 1111	uuuu uuuu
PBC	•	•	•	•	1111 1111	1111 1111	1111 1111	uuuu uuuu
PBPU	•	•	•	•	0000 0000	0000 0000	0000 0000	uuuu uuuu
IICC0	•	•	•		---- 000-	---- 000-	---- 000-	---- uu-
SIMTOC				•	0000 0000	0000 0000	0000 0000	uuuu uuuu
IICC1	•	•	•		1000 0001	1000 0001	1000 0001	uuuu uuuu
SIMC0				•	111- 0000	111- 0000	111- 0000	uuu- uuuu
IICD	•	•	•		xxxx xxxx	xxxx xxxx	xxxx xxxx	uuuu uuuu
SIMC1				•	1000 0001	1000 0001	1000 0001	uuuu uuuu
IICA	•	•	•		0000 000-	0000 000-	0000 000-	uuuu uu-
SIMD				•	xxxx xxxx	xxxx xxxx	xxxx xxxx	uuuu uuuu
IICTOC	•	•	•		0000 0000	0000 0000	0000 0000	uuuu uuuu
SIMA/SIMC2				•	0000 0000	0000 0000	0000 0000	uuuu uuuu
U0SR	•	•	•	•	0000 1011	0000 1011	0000 1011	uuuu uuuu
U0CR1	•	•	•	•	0000 00x0	0000 00x0	0000 00x0	uuuu uuuu

Register	BS86C08C	BS86D12C	BS86E16C	BS86D20C	Power On Reset	LVR Reset (Normal Operation)	WDT Time-out (Normal Operation)	WDT Time-out (IDLE/SLEEP)
U0CR2	•	•	•	•	0000 0000	0000 0000	0000 0000	uuuu uuuu
TXR_RXR0	•	•	•	•	xxxx xxxx	xxxx xxxx	xxxx xxxx	uuuu uuuu
BRG0	•	•	•	•	xxxx xxxx	xxxx xxxx	xxxx xxxx	uuuu uuuu
SADOL	•	•	•	•	xxxx ----	xxxx ----	xxxx ----	uuuu ---- (ADRFS=0)
								uuuu uuuu (ADRFS=1)
SADOH	•	•	•	•	xxxx xxxx	xxxx xxxx	xxxx xxxx	uuuu uuuu (ADRFS=0)
								---- uuuu (ADRFS=1)
SADC0	•	•	•	•	0000 0000	0000 0000	0000 0000	uuuu uuuu
SADC1	•	•	•	•	0000 0000	0000 0000	0000 0000	uuuu uuuu
ACERL	•	•	•	•	0000 0000	0000 0000	0000 0000	uuuu uuuu
TMPC	•	•	•	•	0--- 0000	0--- 0000	0--- 0000	u--- uuuu
					0-00 0000	0-00 0000	0-00 0000	u-uu uuuu
IFS0	•	•	•	•	0000 0000	0000 0000	0000 0000	uuuu uuuu
					---- 0-0	---- 0-0	---- 0-0	---- -u-u
					0000 0000	0000 0000	0000 0000	uuuu uuuu
IFS1	•	•	•	•	---- -111	---- -111	---- -111	---- -uuu
					0000 0000	0000 0000	0000 0000	uuuu uuuu
					0000 0000	0000 0000	0000 0000	uuuu uuuu
IFS2	•	•	•	•	-0-- ----	-0-- ----	-0-- ----	-0-- ----
					0000 0000	0000 0000	0000 0000	uuuu uuuu
LVDC	•	•	•	•	--00 0000	--00 0000	--00 0000	--uu uuuu
PC	•	•	•	•	---- 1111	---- 1111	---- 1111	---- uuuu
					1111 1111	1111 1111	1111 1111	uuuu uuuu
PCC	•	•	•	•	---- 1111	---- 1111	---- 1111	---- uuuu
					1111 1111	1111 1111	1111 1111	uuuu uuuu
PCPU	•	•	•	•	---- 0000	---- 0000	---- 0000	---- uuuu
					0000 0000	0000 0000	0000 0000	uuuu uuuu
MFI			•	•	--00 --00	--00 --00	--00 --00	--uu --uu
CTRL	•	•	•	•	0-00 -x00	0-00 -100	0-00 -x00	u-uu -uuu
					0-00 0x00	0-00 0100	0-00 0x00	u-uu uuuu
PD	•	•	•	•	1111 1111	1111 1111	1111 1111	uuuu uuuu
					---- 1111	---- 1111	---- 1111	---- uuuu
PDC	•	•	•	•	1111 1111	1111 1111	1111 1111	uuuu uuuu
					---- 1111	---- 1111	---- 1111	---- uuuu
PDCU	•	•	•	•	0000 0000	0000 0000	0000 0000	uuuu uuuu
					---- 0000	---- 0000	---- 0000	---- uuuu
PE			•		1111 1111	1111 1111	1111 1111	uuuu uuuu
PEC			•		1111 1111	1111 1111	1111 1111	uuuu uuuu
PEPU			•		0000 0000	0000 0000	0000 0000	uuuu uuuu
TKTMR	•	•	•	•	0000 0000	0000 0000	0000 0000	uuuu uuuu
TKC0	•	•	•	•	-000 0000	-000 0000	-000 0000	-uuu uuuu
TK16DL	•	•	•	•	0000 0000	0000 0000	0000 0000	uuuu uuuu
TK16DH	•	•	•	•	0000 0000	0000 0000	0000 0000	uuuu uuuu
TKC1	•	•	•	•	---- --11	---- --11	---- --11	---- --uu

Register	BS86C08C	BS86D12C	BS86E16C	BS86D20C	Power On Reset	LVR Reset (Normal Operation)	WDT Time-out (Normal Operation)	WDT Time-out (IDLE/SLEEP)
TKM016DL	•	•	•	•	0000 0000	0000 0000	0000 0000	uuuu uuuu
TKM016DH	•	•	•	•	0000 0000	0000 0000	0000 0000	uuuu uuuu
TKM0ROL	•	•	•	•	0000 0000	0000 0000	0000 0000	uuuu uuuu
TKM0ROH	•	•	•	•	---- --00	---- --00	---- --00	---- --uu
TKM0C0	•	•	•	•	0000 0000	0000 0000	0000 0000	uuuu uuuu
TKM0C1	•	•	•	•	0-00 0000	0-00 0000	0-00 0000	u-uu uuuu
TKM116DL	•	•	•	•	0000 0000	0000 0000	0000 0000	uuuu uuuu
TKM116DH	•	•	•	•	0000 0000	0000 0000	0000 0000	uuuu uuuu
TKM1ROL	•	•	•	•	0000 0000	0000 0000	0000 0000	uuuu uuuu
TKM1ROH	•	•	•	•	---- --00	---- --00	---- --00	---- --uu
TKM1C0	•	•	•	•	0000 0000	0000 0000	0000 0000	uuuu uuuu
TKM1C1	•	•	•	•	0-00 0000	0-00 0000	0-00 0000	u-uu uuuu
TKM216DL		•	•	•	0000 0000	0000 0000	0000 0000	uuuu uuuu
TKM216DH		•	•	•	0000 0000	0000 0000	0000 0000	uuuu uuuu
TKM2ROL		•	•	•	0000 0000	0000 0000	0000 0000	uuuu uuuu
TKM2ROH		•	•	•	---- --00	---- --00	---- --00	---- --uu
TKM2C0		•	•	•	0000 0000	0000 0000	0000 0000	uuuu uuuu
TKM2C1		•	•	•	0-00 0000	0-00 0000	0-00 0000	u-uu uuuu
TKM316DL			•	•	0000 0000	0000 0000	0000 0000	uuuu uuuu
TKM316DH			•	•	0000 0000	0000 0000	0000 0000	uuuu uuuu
TKM3ROL			•	•	0000 0000	0000 0000	0000 0000	uuuu uuuu
TKM3ROH			•	•	---- --00	---- --00	---- --00	---- --uu
TKM3C0			•	•	0000 0000	0000 0000	0000 0000	uuuu uuuu
TKM3C1			•	•	0-00 0000	0-00 0000	0-00 0000	u-uu uuuu
CTM0C0	•	•	•	•	0000 0000	0000 0000	0000 0000	uuuu uuuu
CTM0C1	•	•	•	•	0000 0000	0000 0000	0000 0000	uuuu uuuu
CTM0DL	•	•	•	•	0000 0000	0000 0000	0000 0000	uuuu uuuu
CTM0DH	•	•	•	•	---- --00	---- --00	---- --00	---- --uu
CTM0AL	•	•	•	•	0000 0000	0000 0000	0000 0000	uuuu uuuu
CTM0AH	•	•	•	•	---- --00	---- --00	---- --00	---- --uu
PTM0C0	•	•	•	•	0000 0---	0000 0---	0000 0---	uuuu u---
PTM0C1	•	•	•	•	0000 0000	0000 0000	0000 0000	uuuu uuuu
PTM0DL	•	•	•	•	0000 0000	0000 0000	0000 0000	uuuu uuuu
PTM0DH	•	•	•	•	---- --00	---- --00	---- --00	---- --uu
PTM0AL	•	•	•	•	0000 0000	0000 0000	0000 0000	uuuu uuuu
PTM0AH	•	•	•	•	---- --00	---- --00	---- --00	---- --uu
PTM0RPL	•	•	•	•	0000 0000	0000 0000	0000 0000	uuuu uuuu
PTM0RPH	•	•	•	•	---- --00	---- --00	---- --00	---- --uu
PTM1C0			•	•	0000 0---	0000 0---	0000 0---	uuuu u---
PTM1C1			•	•	0000 0000	0000 0000	0000 0000	uuuu uuuu
PTM1DL			•	•	0000 0000	0000 0000	0000 0000	uuuu uuuu
PTM1DH			•	•	---- --00	---- --00	---- --00	---- --uu
PTM1AL			•	•	0000 0000	0000 0000	0000 0000	uuuu uuuu
PTM1AH			•	•	---- --00	---- --00	---- --00	---- --uu
PTM1RPL			•	•	0000 0000	0000 0000	0000 0000	uuuu uuuu

Register	BS86C08C	BS86D12C	BS86E16C	BS86D20C	Power On Reset	LVR Reset (Normal Operation)	WDT Time-out (Normal Operation)	WDT Time-out (IDLE/SLEEP)
PTM1RPH			•	•	---- --00	---- --00	---- --00	---- --uu
U1SR			•		0000 1011	0000 1011	0000 1011	uuuu uuuu
TKM416DL				•	0000 0000	0000 0000	0000 0000	uuuu uuuu
U1CR1			•		0000 00x0	0000 00x0	0000 00x0	uuuu uuuu
TKM416DH				•	0000 0000	0000 0000	0000 0000	uuuu uuuu
U1CR2			•		0000 0000	0000 0000	0000 0000	uuuu uuuu
TKM4ROL				•	0000 0000	0000 0000	0000 0000	uuuu uuuu
TXR_RXR1			•		xxxx xxxx	xxxx xxxx	xxxx xxxx	uuuu uuuu
TKM4ROH				•	---- --00	---- --00	---- --00	---- --uu
BRG1			•		xxxx xxxx	xxxx xxxx	xxxx xxxx	uuuu uuuu
TKM4C0				•	0000 0000	0000 0000	0000 0000	uuuu uuuu
PF			•		---- 1111	---- 1111	---- 1111	---- uuuu
TKM4C1				•	0-00 0000	0-00 0000	0-00 0000	u-uu uuuu
PFC			•		---- 1111	---- 1111	---- 1111	---- uuuu
PFPU			•		---- 0000	---- 0000	---- 0000	---- uuuu
SLEDC2			•		--01 0101	--01 0101	--01 0101	--uu uuuu
SLEDCOM0	•	•	•	•	0--0 0000	0--0 0000	0--0 0000	u--u uuuu
SLEDCOM1	•	•			---- 0000	---- 0000	---- 0000	---- uuuu
			•	•	0000 0000	0000 0000	0000 0000	uuuu uuuu
SLEDCOM2	•	•	•		0000 0000	0000 0000	0000 0000	uuuu uuuu
				•	---- 0000	---- 0000	---- 0000	---- uuuu
SLEDCOM3			•		0000 0000	0000 0000	0000 0000	uuuu uuuu
SLEDCOM4			•		---- 0000	---- 0000	---- 0000	---- uuuu
PMPS			•		---- --00	---- --00	---- --00	---- --uu
EEC	•	•	•	•	---- 0000	---- 0000	---- 0000	---- uuuu

Note: “u” stands for unchanged

“x” stands for unknown

“-” stands for unimplemented

Input/Output Ports

Holtek microcontrollers offer considerable flexibility on their I/O ports. With the input or output designation of every pin fully under user program control, pull-high selections for all ports and wake-up selections on certain pins, the user is provided with an I/O structure to meet the needs of a wide range of application possibilities.

These devices provide bidirectional input/output lines. These I/O ports are mapped to the RAM Data Memory with specific addresses as shown in the Special Purpose Data Memory table. All of these I/O ports can be used for input and output operations. For input operation, these ports are non-latching, which means the inputs must be ready at the T2 rising edge of instruction “MOV A, [m]”, where “m” denotes the port address. For output operation, all the data is latched and remains unchanged until the output latch is rewritten.

Register Name	Bit							
	7	6	5	4	3	2	1	0
PA	PA7	—	—	PA4	PA3	PA2	PA1	PA0
PAC	PAC7	—	—	PAC4	PAC3	PAC2	PAC1	PAC0
PAPU	PAPU7	—	—	PAPU4	PAPU3	PAPU2	PAPU1	PAPU0
PAWU	PAWU7	—	—	PAWU4	PAWU3	PAWU2	PAWU1	PAWU0
PB	PB7	PB6	PB5	PB4	PB3	PB2	PB1	PB0
PBC	PBC7	PBC6	PBC5	PBC4	PBC3	PBC2	PBC1	PBC0
PBPU	PBPU7	PBPU6	PBPU5	PBPU4	PBPU3	PBPU2	PBPU1	PBPU0
PC	—	—	—	—	PC3	PC2	PC1	PC0
PCC	—	—	—	—	PCC3	PCC2	PCC1	PCC0
PCPU	—	—	—	—	PCPU3	PCPU2	PCPU1	PCPU0
PD	PD7	PD6	PD5	PD4	PD3	PD2	PD1	PD0
PDC	PDC7	PDC6	PDC5	PDC4	PDC3	PDC2	PDC1	PDC0
PDPU	PDPU7	PDPU6	PDPU5	PDPU4	PDPU3	PDPU2	PDPU1	PDPU0

“—”: Unimplemented, read as “0”

I/O Logic Function Register List – BS86C08C/BS86D12C

Register Name	Bit							
	7	6	5	4	3	2	1	0
PA	PA7	—	—	PA4	PA3	PA2	PA1	PA0
PAC	PAC7	—	—	PAC4	PAC3	PAC2	PAC1	PAC0
PAPU	PAPU7	—	—	PAPU4	PAPU3	PAPU2	PAPU1	PAPU0
PAWU	PAWU7	—	—	PAWU4	PAWU3	PAWU2	PAWU1	PAWU0
PB	PB7	PB6	PB5	PB4	PB3	PB2	PB1	PB0
PBC	PBC7	PBC6	PBC5	PBC4	PBC3	PBC2	PBC1	PBC0
PBPU	PBPU7	PBPU6	PBPU5	PBPU4	PBPU3	PBPU2	PBPU1	PBPU0
PC	PC7	PC6	PC5	PC4	PC3	PC2	PC1	PC0
PCC	PCC7	PCC6	PCC5	PCC4	PCC3	PCC2	PCC1	PCC0
PCPU	PCPU7	PCPU6	PCPU5	PCPU4	PCPU3	PCPU2	PCPU1	PCPU0
PD	PD7	PD6	PD5	PD4	PD3	PD2	PD1	PD0
PDC	PDC7	PDC6	PDC5	PDC4	PDC3	PDC2	PDC1	PDC0
PDPU	PDPU7	PDPU6	PDPU5	PDPU4	PDPU3	PDPU2	PDPU1	PDPU0
PE	PE7	PE6	PE5	PE4	PE3	PE2	PE1	PE0
PEC	PEC7	PEC6	PEC5	PEC4	PEC3	PEC2	PEC1	PEC0
PEPU	PEPU7	PEPU6	PEPU5	PEPU4	PEPU3	PEPU2	PEPU1	PEPU0
PF	—	—	—	—	PF3	PF2	PF1	PF0
PFC	—	—	—	—	PFC3	PFC2	PFC1	PFC0
PFPU	—	—	—	—	PFPU3	PFPU2	PFPU1	PFPU0

“—”: Unimplemented, read as “0”

I/O Logic Function Register List – BS86E16C

Register Name	Bit							
	7	6	5	4	3	2	1	0
PA	PA7	—	—	PA4	PA3	PA2	PA1	PA0
PAC	PAC7	—	—	PAC4	PAC3	PAC2	PAC1	PAC0
PAPU	PAPU7	—	—	PAPU4	PAPU3	PAPU2	PAPU1	PAPU0
PAWU	PAWU7	—	—	PAWU4	PAWU3	PAWU2	PAWU1	PAWU0
PB	PB7	PB6	PB5	PB4	PB3	PB2	PB1	PB0
PBC	PBC7	PBC6	PBC5	PBC4	PBC3	PBC2	PBC1	PBC0
PBPU	PBPU7	PBPU6	PBPU5	PBPU4	PBPU3	PBPU2	PBPU1	PBPU0
PC	PC7	PC6	PC5	PC4	PC3	PC2	PC1	PC0
PCC	PCC7	PCC6	PCC5	PCC4	PCC3	PCC2	PCC1	PCC0
PCPU	PCPU7	PCPU6	PCPU5	PCPU4	PCPU3	PCPU2	PCPU1	PCPU0
PD	—	—	—	—	PD3	PD2	PD1	PD0
PDC	—	—	—	—	PDC3	PDC2	PDC1	PDC0
PDPU	—	—	—	—	PDPU3	PDPU2	PDPU1	PDPU0

“—”: Unimplemented, read as “0”

I/O Logic Function Register List – BS86D20C

Pull-high Resistors

Many product applications require pull-high resistors for their switch inputs usually requiring the use of an external resistor. To eliminate the need for these external resistors, all I/O pins, when configured as an input have the capability of being connected to an internal pull-high resistor. These pull-high resistors are selected using the relevant pull-high control registers and are implemented using weak PMOS transistors.

• **PxPU Register**

Bit	7	6	5	4	3	2	1	0
Name	PxPU7	PxPU6	PxPU5	PxPU4	PxPU3	PxPU2	PxPU1	PxPU0
R/W	R/W	R/W	R/W	R/W	R/W	R/W	R/W	R/W
POR	0	0	0	0	0	0	0	0

PxPUn: I/O Port x Pin pull-high function control

0: Disable

1: Enable

The PxPUn bit is used to control the pin pull-high function. Here the “x” is the Port name which can be A, B, C, D, E and F depending upon the selected device. However, the actual available bits for each I/O Port may be different.

Port A Wake-up

The HALT instruction forces the microcontroller into the SLEEP or IDLE Mode which preserves power, a feature that is important for battery and other low-power applications. Various methods exist to wake-up the microcontroller, one of which is to change the logic condition on one of the Port A pins from high to low. This function is especially suitable for applications that can be woken up via external switches. Each pin on Port A can be selected individually to have this wake-up feature using the PAWU register.

• **PAWU Register**

Bit	7	6	5	4	3	2	1	0
Name	PAWU7	—	—	PAWU4	PAWU3	PAWU2	PAWU1	PAWU0
R/W	R/W	—	—	R/W	R/W	R/W	R/W	R/W
POR	0	—	—	0	0	0	0	0

Bit 7, 4~0 **PAWU7, PAWU4~PAWU0:** Port A pin Wake-up function control
 0: Disable
 1: Enable

Bit 6~5 Unimplemented, read as “0”

I/O Port Control Registers

Each I/O Port has its own control register which controls the input/output configuration. With this control register, each I/O pin with or without pull-high resistors can be reconfigured dynamically under software control. For the I/O pin to function as an input, the corresponding bit of the control register must be written as a “1”. This will then allow the logic state of the input pin to be directly read by instructions. When the corresponding bit of the control register is written as a “0”, the I/O pin will be setup as a CMOS output. If the pin is currently setup as an output, instructions can still be used to read the output register. However, it should be noted that the program will in fact only read the status of the output data latch and not the actual logic status of the output pin.

• **PxC Register**

Bit	7	6	5	4	3	2	1	0
Name	PxC7	PxC6	PxC5	PxC4	PxC3	PxC2	PxC1	PxC0
R/W	R/W	R/W	R/W	R/W	R/W	R/W	R/W	R/W
POR	1	1	1	1	1	1	1	1

PxCn: I/O Port x Pin type selection

0: Output

1: Input

The PxCn bit is used to control the pin type selection. Here the “x” is the Port name which can be A, B, C, D, E and F depending upon the selected device. However, the actual available bits for each I/O Port may be different.

I/O Port Source Current Selection

These devices support different output source current driving capability for each I/O port. With the selection register, SLEDCn, specific I/O port can support four levels of the source current driving capability. These source current selection bits are available when the corresponding pin is configured as a CMOS output. Otherwise, these select bits have no effect. Users should refer to the Input/Output Characteristics section to select the desired output source current for different applications.

Register Name	Bit							
	7	6	5	4	3	2	1	0
SLEDC0	PBPS3	PBPS2	PBPS1	PBPS0	PAPS3	PAPS2	PAPS1	PAPS0
SLEDC1	PDPS3	PDPS2	PDPS1	PDPS0	—	—	PCPS1	PCPS0

I/O Port Source Current Selection Register List – BS86C08C/BS86D12C

Register Name	Bit							
	7	6	5	4	3	2	1	0
SLEDC0	PBPS3	PBPS2	PBPS1	PBPS0	PAPS3	PAPS2	PAPS1	PAPS0
SLEDC1	PDPS3	PDPS2	PDPS1	PDPS0	PCPS3	PCPS2	PCPS1	PCPS0
SLEDC2	—	—	PFPS1	PFPS0	PEPS3	PEPS2	PEPS1	PEPS0

I/O Port Source Current Selection Register List – BS86E16C

Register Name	Bit							
	7	6	5	4	3	2	1	0
SLEDC0	PBPS3	PBPS2	PBPS1	PBPS0	PAPS3	PAPS2	PAPS1	PAPS0
SLEDC1	—	—	PDPS1	PDPS0	PCPS3	PCPS2	PCPS1	PCPS0

I/O Port Source Current Selection Register List – BS86D20C

• **SLEDC0 Register**

Bit	7	6	5	4	3	2	1	0
Name	PBPS3	PBPS2	PBPS1	PBPS0	PAPS3	PAPS2	PAPS1	PAPS0
R/W	R/W	R/W	R/W	R/W	R/W	R/W	R/W	R/W
POR	0	1	0	1	0	1	0	1

Bit 7~6 **PBPS3~PBPS2**: PB7~PB4 source current selection

- 00: Source current = Level 0 (Min.)
- 01: Source current = Level 1
- 10: Source current = Level 2
- 11: Source current = Level 3 (Max.)

Bit 5~4 **PBPS1~PBPS0**: PB3~PB0 source current selection

- 00: Source current = Level 0 (Min.)
- 01: Source current = Level 1
- 10: Source current = Level 2
- 11: Source current = Level 3 (Max.)

Bit 3~2 **PAPS3~PAPS2**: PA7 and PA4 source current selection

- 00: Source current = Level 0 (Min.)
- 01: Source current = Level 1
- 10: Source current = Level 2
- 11: Source current = Level 3 (Max.)

Bit 1~0 **PAPS1~PAPS0**: PA3~PA0 source current selection

- 00: Source current = Level 0 (Min.)
- 01: Source current = Level 1
- 10: Source current = Level 2
- 11: Source current = Level 3 (Max.)

• **SLEDC1 Register – BS86C08C/BS86D12C**

Bit	7	6	5	4	3	2	1	0
Name	PDPS3	PDPS2	PDPS1	PDPS0	—	—	PCPS1	PCPS0
R/W	R/W	R/W	R/W	R/W	—	—	R/W	R/W
POR	0	1	0	1	—	—	0	1

Bit 7~6 **PDPS3~PDPS2**: PD7~PD4 source current selection

- 00: Source current = Level 0 (Min.)
- 01: Source current = Level 1
- 10: Source current = Level 2
- 11: Source current = Level 3 (Max.)

- Bit 5~4 **PDPS1~PDPS0:** PD3~PD0 source current selection
 00: Source current = Level 0 (Min.)
 01: Source current = Level 1
 10: Source current = Level 2
 11: Source current = Level 3 (Max.)
- Bit 3~2 Unimplemented, read as “0”
- Bit 1~0 **PCPS1~PCPS0:** PC3~PC0 source current selection
 00: Source current = Level 0 (Min.)
 01: Source current = Level 1
 10: Source current = Level 2
 11: Source current = Level 3 (Max.)

• **SLEDC1 Register – BS86E16C**

Bit	7	6	5	4	3	2	1	0
Name	PDPS3	PDPS2	PDPS1	PDPS0	PCPS3	PCPS2	PCPS1	PCPS0
R/W	R/W	R/W	R/W	R/W	R/W	R/W	R/W	R/W
POR	0	1	0	1	0	1	0	1

- Bit 7~6 **PDPS3~PDPS2:** PD7~PD4 source current selection
 00: Source current = Level 0 (Min.)
 01: Source current = Level 1
 10: Source current = Level 2
 11: Source current = Level 3 (Max.)
- Bit 5~4 **PDPS1~PDPS0:** PD3~PD0 source current selection
 00: Source current = Level 0 (Min.)
 01: Source current = Level 1
 10: Source current = Level 2
 11: Source current = Level 3 (Max.)
- Bit 3~2 **PCPS3~PCPS2:** PC7~PC4 source current selection
 00: Source current = Level 0 (Min.)
 01: Source current = Level 1
 10: Source current = Level 2
 11: Source current = Level 3 (Max.)
- Bit 1~0 **PCPS1~PCPS0:** PC3~PC0 source current selection
 00: Source current = Level 0 (Min.)
 01: Source current = Level 1
 10: Source current = Level 2
 11: Source current = Level 3 (Max.)

• **SLEDC1 Register – BS86D20C**

Bit	7	6	5	4	3	2	1	0
Name	—	—	PDPS1	PDPS0	PCPS3	PCPS2	PCPS1	PCPS0
R/W	—	—	R/W	R/W	R/W	R/W	R/W	R/W
POR	—	—	0	1	0	1	0	1

- Bit 7~6 Unimplemented, read as “0”
- Bit 5~4 **PDPS1~PDPS0:** PD3~PD0 source current selection
 00: Source current = Level 0 (Min.)
 01: Source current = Level 1
 10: Source current = Level 2
 11: Source current = Level 3 (Max.)
- Bit 3~2 **PCPS3~PCPS2:** PC7~PC4 source current selection
 00: Source current = Level 0 (Min.)
 01: Source current = Level 1
 10: Source current = Level 2
 11: Source current = Level 3 (Max.)

Bit 1~0 **PCPS1~PCPS0**: PC3~PC0 source current selection
 00: Source current = Level 0 (Min.)
 01: Source current = Level 1
 10: Source current = Level 2
 11: Source current = Level 3 (Max.)

• **SLEDC2 Register – BS86E16C**

Bit	7	6	5	4	3	2	1	0
Name	—	—	PFPS1	PFPS0	PEPS3	PEPS2	PEPS1	PEPS0
R/W	—	—	R/W	R/W	R/W	R/W	R/W	R/W
POR	—	—	0	1	0	1	0	1

Bit 7~6 Unimplemented, read as “0”
 Bit 5~4 **PFPS1~PFPS0**: PF3~PF0 source current selection
 00: Source current = Level 0 (Min.)
 01: Source current = Level 1
 10: Source current = Level 2
 11: Source current = Level 3 (Max.)
 Bit 3~2 **PEPS3~PEPS2**: PE7~PE4 source current selection
 00: Source current = Level 0 (Min.)
 01: Source current = Level 1
 10: Source current = Level 2
 11: Source current = Level 3 (Max.)
 Bit 1~0 **PEPS1~PEPS0**: PE3~PE0 source current selection
 00: Source current = Level 0 (Min.)
 01: Source current = Level 1
 10: Source current = Level 2
 11: Source current = Level 3 (Max.)

I/O Port Sink Current Selection

These devices support different output sink current driving capability for PA, PC, PD, PE and PF ports. With the selection register, SLEDCOMn, specific I/O port can support two levels of the sink current driving capability. These sink current selection bits are available when the corresponding pin is configured as a CMOS output. Otherwise, these select bits have no effect. Users should refer to the Input/Output Characteristics section to select the desired output sink current for different applications.

Register Name	Bit							
	7	6	5	4	3	2	1	0
SLEDCOM0	PANS7	—	—	PANS4	PANS3	PANS2	PANS1	PANS0
SLEDCOM1	—	—	—	—	PCNS3	PCNS2	PCNS1	PCNS0
SLEDCOM2	PDNS7	PDNS6	PDNS5	PDNS4	PDNS3	PDNS2	PDNS1	PDNS0

I/O Port Sink Current Selection Register List – BS86C08C/BS86D12C

Register Name	Bit							
	7	6	5	4	3	2	1	0
SLEDCOM0	PANS7	—	—	PANS4	PANS3	PANS2	PANS1	PANS0
SLEDCOM1	PCNS7	PCNS6	PCNS5	PCNS4	PCNS3	PCNS2	PCNS1	PCNS0
SLEDCOM2	PDNS7	PDNS6	PDNS5	PDNS4	PDNS3	PDNS2	PDNS1	PDNS0
SLEDCOM3	PENS7	PENS6	PENS5	PENS4	PENS3	PENS2	PENS1	PENS0
SLEDCOM4	—	—	—	—	PFNS3	PFNS2	PFNS1	PFNS0

I/O Port Sink Current Selection Register List – BS86E16C

Register Name	Bit							
	7	6	5	4	3	2	1	0
SLEDCOM0	PANS7	—	—	PANS4	PANS3	PANS2	PANS1	PANS0
SLEDCOM1	PCNS7	PCNS6	PCNS5	PCNS4	PCNS3	PCNS2	PCNS1	PCNS0
SLEDCOM2	—	—	—	—	PDNS3	PDNS2	PDNS1	PDNS0

I/O Port Sink Current Selection Register List – BS86D20C

• **SLEDCOM0 Register**

Bit	7	6	5	4	3	2	1	0
Name	PANS7	—	—	PANS4	PANS3	PANS2	PANS1	PANS0
R/W	R/W	—	—	R/W	R/W	R/W	R/W	R/W
POR	0	—	—	0	0	0	0	0

- Bit 7 **PANS7:** PA7 sink current selection
 0: Sink current = Level 0 (Min.)
 1: Sink current = Level 1 (Max.)
- Bit 6~5 Unimplemented, read as “0”
- Bit 4 **PANS4:** PA4 sink current selection
 0: Sink current = Level 0 (Min.)
 1: Sink current = Level 1 (Max.)
- Bit 3 **PANS3:** PA3 sink current selection
 0: Sink current = Level 0 (Min.)
 1: Sink current = Level 1 (Max.)
- Bit 2 **PANS2:** PA2 sink current selection
 0: Sink current = Level 0 (Min.)
 1: Sink current = Level 1 (Max.)
- Bit 1 **PANS1:** PA1 sink current selection
 0: Sink current = Level 0 (Min.)
 1: Sink current = Level 1 (Max.)
- Bit 0 **PANS0:** PA0 sink current selection
 0: Sink current = Level 0 (Min.)
 1: Sink current = Level 1 (Max.)

• **SLEDCOM1 Register – BS86C08C/BS86D12C**

Bit	7	6	5	4	3	2	1	0
Name	—	—	—	—	PCNS3	PCNS2	PCNS1	PCNS0
R/W	—	—	—	—	R/W	R/W	R/W	R/W
POR	—	—	—	—	0	0	0	0

- Bit 7~4 Unimplemented, read as “0”
- Bit 3 **PCNS3:** PC3 sink current selection
 0: Sink current = Level 0 (Min.)
 1: Sink current = Level 1 (Max.)
- Bit 2 **PCNS2:** PC2 sink current selection
 0: Sink current = Level 0 (Min.)
 1: Sink current = Level 1 (Max.)
- Bit 1 **PCNS1:** PC1 sink current selection
 0: Sink current = Level 0 (Min.)
 1: Sink current = Level 1 (Max.)
- Bit 0 **PCNS0:** PC0 sink current selection
 0: Sink current = Level 0 (Min.)
 1: Sink current = Level 1 (Max.)

• **SLEDCOM1 Register – BS86E16C/BS86D20C**

Bit	7	6	5	4	3	2	1	0
Name	PCNS7	PCNS6	PCNS5	PCNS4	PCNS3	PCNS2	PCNS1	PCNS0
R/W	R/W	R/W	R/W	R/W	R/W	R/W	R/W	R/W
POR	0	0	0	0	0	0	0	0

- Bit 7 **PCNS7:** PC7 sink current selection
 0: Sink current = Level 0 (Min.)
 1: Sink current = Level 1 (Max.)
- Bit 6 **PCNS6:** PC6 sink current selection
 0: Sink current = Level 0 (Min.)
 1: Sink current = Level 1 (Max.)
- Bit 5 **PCNS5:** PC5 sink current selection
 0: Sink current = Level 0 (Min.)
 1: Sink current = Level 1 (Max.)
- Bit 4 **PCNS4:** PC4 sink current selection
 0: Sink current = Level 0 (Min.)
 1: Sink current = Level 1 (Max.)
- Bit 3 **PCNS3:** PC3 sink current selection
 0: Sink current = Level 0 (Min.)
 1: Sink current = Level 1 (Max.)
- Bit 2 **PCNS2:** PC2 sink current selection
 0: Sink current = Level 0 (Min.)
 1: Sink current = Level 1 (Max.)
- Bit 1 **PCNS1:** PC1 sink current selection
 0: Sink current = Level 0 (Min.)
 1: Sink current = Level 1 (Max.)
- Bit 0 **PCNS0:** PC0 sink current selection
 0: Sink current = Level 0 (Min.)
 1: Sink current = Level 1 (Max.)

• **SLEDCOM2 Register –BS86C08C/BS86D12C/BS86E16C**

Bit	7	6	5	4	3	2	1	0
Name	PDNS7	PDNS6	PDNS5	PDNS4	PDNS3	PDNS2	PDNS1	PDNS0
R/W	R/W	R/W	R/W	R/W	R/W	R/W	R/W	R/W
POR	0	0	0	0	0	0	0	0

- Bit 7 **PDNS7:** PD7 sink current selection
 0: Sink current = Level 0 (Min.)
 1: Sink current = Level 1 (Max.)
- Bit 6 **PDNS6:** PD6 sink current selection
 0: Sink current = Level 0 (Min.)
 1: Sink current = Level 1 (Max.)
- Bit 5 **PDNS5:** PD5 sink current selection
 0: Sink current = Level 0 (Min.)
 1: Sink current = Level 1 (Max.)
- Bit 4 **PDNS4:** PD4 sink current selection
 0: Sink current = Level 0 (Min.)
 1: Sink current = Level 1 (Max.)
- Bit 3 **PDNS3:** PD3 sink current selection
 0: Sink current = Level 0 (Min.)
 1: Sink current = Level 1 (Max.)

- Bit 2 **PDNS2:** PD2 sink current selection
 0: Sink current = Level 0 (Min.)
 1: Sink current = Level 1 (Max.)
- Bit 1 **PDNS1:** PD1 sink current selection
 0: Sink current = Level 0 (Min.)
 1: Sink current = Level 1 (Max.)
- Bit 0 **PDNS0:** PD0 sink current selection
 0: Sink current = Level 0 (Min.)
 1: Sink current = Level 1 (Max.)

• **SLEDCOM2 Register – BS86D20C**

Bit	7	6	5	4	3	2	1	0
Name	—	—	—	—	PDNS3	PDNS2	PDNS1	PDNS0
R/W	—	—	—	—	R/W	R/W	R/W	R/W
POR	—	—	—	—	0	0	0	0

- Bit 7~4 Unimplemented, read as “0”
- Bit 3 **PDNS3:** PD3 sink current selection
 0: Sink current = Level 0 (Min.)
 1: Sink current = Level 1 (Max.)
- Bit 2 **PDNS2:** PD2 sink current selection
 0: Sink current = Level 0 (Min.)
 1: Sink current = Level 1 (Max.)
- Bit 1 **PDNS1:** PD1 sink current selection
 0: Sink current = Level 0 (Min.)
 1: Sink current = Level 1 (Max.)
- Bit 0 **PDNS0:** PD0 sink current selection
 0: Sink current = Level 0 (Min.)
 1: Sink current = Level 1 (Max.)

• **SLEDCOM3 Register – BS86E16C**

Bit	7	6	5	4	3	2	1	0
Name	PENS7	PENS6	PENS5	PENS4	PENS3	PENS2	PENS1	PENS0
R/W	R/W	R/W	R/W	R/W	R/W	R/W	R/W	R/W
POR	0	0	0	0	0	0	0	0

- Bit 7 **PENS7:** PE7 sink current selection
 0: Sink current = Level 0 (Min.)
 1: Sink current = Level 1 (Max.)
- Bit 6 **PENS6:** PE6 sink current selection
 0: Sink current = Level 0 (Min.)
 1: Sink current = Level 1 (Max.)
- Bit 5 **PENS5:** PE5 sink current selection
 0: Sink current = Level 0 (Min.)
 1: Sink current = Level 1 (Max.)
- Bit 4 **PENS4:** PE4 sink current selection
 0: Sink current = Level 0 (Min.)
 1: Sink current = Level 1 (Max.)
- Bit 3 **PENS3:** PE3 sink current selection
 0: Sink current = Level 0 (Min.)
 1: Sink current = Level 1 (Max.)
- Bit 2 **PENS2:** PE2 sink current selection
 0: Sink current = Level 0 (Min.)
 1: Sink current = Level 1 (Max.)

- Bit 1 **PENS1:** PE1 sink current selection
 0: Sink current = Level 0 (Min.)
 1: Sink current = Level 1 (Max.)
- Bit 0 **PENS0:** PE0 sink current selection
 0: Sink current = Level 0 (Min.)
 1: Sink current = Level 1 (Max.)

• SLEDCOM4 Register – BS86E16C

Bit	7	6	5	4	3	2	1	0
Name	—	—	—	—	PFNS3	PFNS2	PFNS1	PFNS0
R/W	—	—	—	—	R/W	R/W	R/W	R/W
POR	—	—	—	—	0	0	0	0

- Bit 7~4 Unimplemented, read as “0”
- Bit 3 **PFNS3:** PF3 sink current selection
 0: Sink current = Level 0 (Min.)
 1: Sink current = Level 1 (Max.)
- Bit 2 **PFNS2:** PF2 sink current selection
 0: Sink current = Level 0 (Min.)
 1: Sink current = Level 1 (Max.)
- Bit 1 **PFNS1:** PF1 sink current selection
 0: Sink current = Level 0 (Min.)
 1: Sink current = Level 1 (Max.)
- Bit 0 **PFNS0:** PF0 sink current selection
 0: Sink current = Level 0 (Min.)
 1: Sink current = Level 1 (Max.)

I/O Port Power Source Control – BS86E16C Only

The BS86E16C device supports different I/O port power source selections for PD7~PD6 pins. The port power can come from either the power pin VDD or VDDIO which is determined by using the PMPS1~PMPS0 bits in the PMPS register. An important point to know is that the input power voltage on the VDDIO pin should be equal to or less than the device supply power voltage when the VDDIO pin is selected as the port power supply pin.

With the exception of OCDS, the multi-power function is only effective when the pin is set to have a digital input or output function.

• PMPS Register

Bit	7	6	5	4	3	2	1	0
Name	—	—	—	—	—	—	PMPS1	PMPS0
R/W	—	—	—	—	—	—	R/W	R/W
POR	—	—	—	—	—	—	0	0

- Bit 7~2 Unimplemented, read as “0”
- Bit 1~0 **PMPS1~PMPS0:** PD7~PD6 pin power source selection
 0x: VDD
 1x: VDDIO

Pin-remapping Function

The flexibility of the microcontroller range is greatly enhanced by the use of pins that have more than one function. Limited numbers of pins can force serious design constraints on designers but by supplying pins with multi-functions, many of these difficulties can be overcome. The way in which the pin function of specific pins is selected is different for each function and a priority order is established where more than one pin function is selected simultaneously.

Pin-remapping Selection Register

The limited number of supplied pins in a package can impose restrictions on the amount of functions a certain device can contain. However by allowing the same pins to share several different functions and providing a means of function selection, a wide range of different functions can be incorporated into even relatively small package sizes.

Register Name	Bit							
	7	6	5	4	3	2	1	0
IFS0	SDAPS1	SDAPS0	SCLPS1	SCLPS0	TX0PS1	TX0PS0	RX0PS1	RX0PS0
IFS1	—	—	—	—	—	CTCK0PS	—	CTP0PS
IFS2	—	RX0EN	—	—	—	—	—	—

Pin-remapping Selection Register List – BS86C08C/BS86D12C

Register Name	Bit							
	7	6	5	4	3	2	1	0
IFS0	SDAPS1	SDAPS0	SCLPS1	SCLPS0	TX0PS1	TX0PS0	RX0PS1	RX0PS0
IFS1	PTP1PS	PTP1IPS	PTP0PS	CTP0BPS	CTCK0PS1	CTCK0PS0	CTP0PS1	CTP0PS0
IFS2	RX1EN	RX0EN	TX1PS1	TX1PS0	RX1PS1	RX1PS0	PTP1BPS	PTCK1PS

Pin-remapping Selection Register List – BS86E16C

Register Name	Bit							
	7	6	5	4	3	2	1	0
IFS0	SDOPS	SCSBPS	SDIPS	SCKPS	TX0PS1	TX0PS0	RX0PS1	RX0PS0
IFS1	—	—	—	—	—	RX0EN	PTCK0PS	PTP0IPS

Pin-remapping Selection Register List – BS86D20C

• IFS0 Register – BS86C08C/BS86D12C

Bit	7	6	5	4	3	2	1	0
Name	SDAPS1	SDAPS0	SCLPS1	SCLPS0	TX0PS1	TX0PS0	RX0PS1	RX0PS0
R/W	R/W	R/W	R/W	R/W	R/W	R/W	R/W	R/W
POR	0	0	0	0	0	0	0	0

- Bit 7~6 **SDAPS1~SDAPS0:** SDA pin remapping function selection
 00: SDA on PD7
 01: SDA on PA3
 10: SDA on PC3
 11: SDA on PD7
- Bit 5~4 **SCLPS1~SCLPS0:** SCL pin remapping function selection
 00: SCL on PD6
 01: SCL on PA1
 10: SCL on PC2
 11: SCL on PD6
- Bit 3~2 **TX0PS1~TX0PS0:** TX0 pin remapping function selection
 00: TX0 on PA3
 01: TX0 on PA3
 10: TX0 on PC3
 11: TX0 on PD7
- Bit 1~0 **RX0PS1~RX0PS0:** RX0 pin remapping function selection
 00: RX0 on PA1
 01: RX0 on PA1
 10: RX0 on PC2
 11: RX0 on PD6

• **IFS0 Register – BS86E16C**

Bit	7	6	5	4	3	2	1	0
Name	SDAPS1	SDAPS0	SCLPS1	SCLPS0	TX0PS1	TX0PS0	RX0PS1	RX0PS0
R/W	R/W	R/W	R/W	R/W	R/W	R/W	R/W	R/W
POR	0	0	0	0	0	0	0	0

- Bit 7~6 **SDAPS1~SDAPS0**: SDA pin remapping function selection
 00: SDA on PD7
 01: SDA on PA3
 10: SDA on PC3
 11: SDA on PC7
- Bit 5~4 **SCLPS1~SCLPS0**: SCL pin remapping function selection
 00: SCL on PD6
 01: SCL on PA1
 10: SCL on PC2
 11: SCL on PC6
- Bit 3~2 **TX0PS1~TX0PS0**: TX0 pin remapping function selection
 00: TX0 on PA3
 01: TX0 on PE1
 10: TX0 on PC3
 11: TX0 on PD7
- Bit 1~0 **RX0PS1~RX0PS0**: RX0 pin remapping function selection
 00: RX0 on PA1
 01: RX0 on PE0
 10: RX0 on PC2
 11: RX0 on PD6

• **IFS0 Register – BS86D20C**

Bit	7	6	5	4	3	2	1	0
Name	SDOPS	SCSBPS	SDIPS	SCKPS	TX0PS1	TX0PS0	RX0PS1	RX0PS0
R/W	R/W	R/W	R/W	R/W	R/W	R/W	R/W	R/W
POR	0	0	0	0	0	0	0	0

- Bit 7 **SDOPS**: SDO pin remapping function selection
 0: SDO on PA0
 1: SDO on PC5
- Bit 6 **SCSBPS**: \overline{SCS} pin remapping function selection
 0: \overline{SCS} on PA2
 1: \overline{SCS} on PC4
- Bit 5 **SDIPS**: SDI/SDA pin remapping function selection
 0: SDI/SDA on PA3
 1: SDI/SDA on PA1
- Bit 4 **SCKPS**: SCK/SCL pin remapping function selection
 0: SCK/SCL on PA7
 1: SCK/SCL on PA4
- Bit 3~2 **TX0PS1~TX0PS0**: TX0 pin remapping function selection
 00: TX0 on PA7
 01: TX0 on PD1
 10: TX0 on PA1
 11: TX0 on PA7
- Bit 1~0 **RX0PS1~RX0PS0**: RX0 pin remapping function selection
 00: RX0 on PA3
 01: RX0 on PD0
 10: RX0 on PA4
 11: RX0 on PA3

• **IFS1 Register – BS86C08C/BS86D12C**

Bit	7	6	5	4	3	2	1	0
Name	—	—	—	—	—	CTCK0PS	—	CTP0PS
R/W	—	—	—	—	—	R/W	—	R/W
POR	—	—	—	—	—	0	—	0

- Bit 7~3 Unimplemented, read as “0”
- Bit 2 **CTCK0PS**: CTCK0 pin remapping function selection
0: CTCK0 on PA7
1: CTCK0 on PC0
- Bit 1 Unimplemented, read as “0”
- Bit 0 **CTP0**: CTP0 pin remapping function selection
0: CTP0 on PA4
1: CTP0 on PC1

• **IFS1 Register – BS86E16C**

Bit	7	6	5	4	3	2	1	0
Name	PTP1PS	PTP1IPS	PTP0PS	CTP0BPS	CTCK0PS1	CTCK0PS0	CTP0PS1	CTP0PS0
R/W	R/W	R/W	R/W	R/W	R/W	R/W	R/W	R/W
POR	0	0	0	0	0	0	0	0

- Bit 7 **PTP1PS**: PTP1 pin remapping function selection
0: PTP1 on PE4
1: PTP1 on PD3
- Bit 6 **PTP1IPS**: PTP1I pin remapping function selection
0: PTP1I on PE6
1: PTP1I on PD2
- Bit 5 **PTP0PS**: PTP0 pin remapping function selection
0: PTP0 on PF3
1: PTP0 on PD5
- Bit 4 **CTP0BPS**: CTP0B pin remapping function selection
0: CTP0B on PF2
1: CTP0B on PA0
- Bit 3~2 **CTCK0PS1~CTCK0PS0**: CTCK0 pin remapping function selection
00: CTCK0 on PA7
01: CTCK0 on PC0
10: CTCK0 on PF1
11: CTCK0 on PA7
- Bit 1~0 **CTP0PS1~CTP0PS0**: CTP0 pin remapping function selection
00: CTP0 on PA4
01: CTP0 on PC1
10: CTP0 on PF0
11: CTP0 on PA4

• **IFS1 Register – BS86D20C**

Bit	7	6	5	4	3	2	1	0
Name	—	—	—	—	—	RX0EN	PTCK0PS	PTP0IPS
R/W	—	—	—	—	—	R/W	R/W	R/W
POR	—	—	—	—	—	0	0	0

- Bit 7~3 Unimplemented, read as "0"
- Bit 2 **RX0EN**: RX0 input enable control
0: Disable
1: Enable

- Bit 1 **PTCK0PS**: PTCK0 pin remapping function selection
 0: PTCK0 on PA0
 1: PTCK0 on PC2
- Bit 0 **PTP0IPS**: PTP0I pin remapping function selection
 0: PTP0I on PA2
 1: PTP0I on PC3

• **IFS2 Register – BS86C08C/BS86D12C**

Bit	7	6	5	4	3	2	1	0
Name	—	RX0EN	—	—	—	—	—	—
R/W	—	R/W	—	—	—	—	—	—
POR	—	0	—	—	—	—	—	—

- Bit 7 Unimplemented, read as “0”
- Bit 6 **RX0EN**: RX0 input enable control
 0: Disable
 1: Enable
- Bit 5~0 Unimplemented, read as “0”

• **IFS2 Register – BS86E16C**

Bit	7	6	5	4	3	2	1	0
Name	RX1EN	RX0EN	TX1PS1	TX1PS0	RX1PS1	RX1PS0	PTP1BPS	PTCK1PS
R/W	R/W	R/W	R/W	R/W	R/W	R/W	R/W	R/W
POR	0	0	0	0	0	0	0	0

- Bit 7 **RX1EN**: RX1 input enable control
 0: Disable
 1: Enable
- Bit 6 **RX0EN**: RX0 input enable control
 0: Disable
 1: Enable
- Bit 5~4 **TX1PS1~TX1PS0**: TX1 pin remapping function selection
 00: TX1 on PF1
 01: TX1 on PE3
 10: TX1 on PD3
 11: TX1 on PA7
- Bit 3~2 **RX1PS1~RX1PS0**: RX1 pin remapping function selection
 00: RX1 on PF0
 01: RX1 on PE2
 10: RX1 on PD2
 11: RX1 on PA4
- Bit 1 **PTP1BPS**: PTP1B pin remapping function selection
 0: PTP1B on PE5
 1: PTP1B on PE3
- Bit 0 **PTCK1PS**: PTCK1 pin remapping function selection
 0: PTCK1 on PE7
 1: PTCK1 on PD4

I/O Pin Structures

The accompanying diagram illustrates the internal structure of the I/O logic function. As the exact logical construction of the I/O pin will differ from this drawing, it is supplied as a guide only to assist with the functional understanding of the I/O logic function. The wide range of pin-shared structures does not permit all types to be shown.

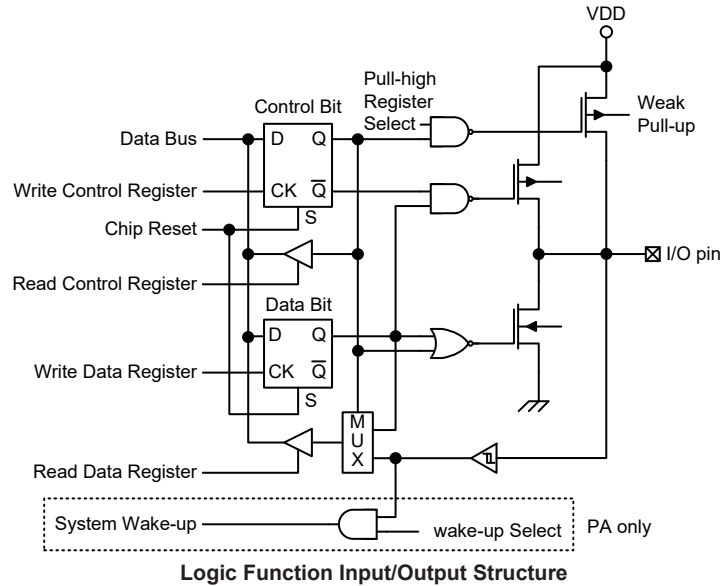

Programming Considerations

Within the user program, one of the things first to consider is port initialisation. After a reset, all of the I/O data and port control registers will be set high. This means that all I/O pins will be defaulted to an input state, the level of which depends on the other connected circuitry and whether pull-high selections have been chosen. If the port control registers are then programmed to setup some pins as outputs, these output pins will have an initial high output value unless the associated port data registers are first programmed. Selecting which pins are inputs and which are outputs can be achieved byte-wide by loading the correct values into the appropriate port control register or by programming individual bits in the port control register using the "SET [m].i" and "CLR [m].i" instructions. Note that when using these bit control instructions, a read-modify-write operation takes place. The microcontroller must first read in the data on the entire port, modify it to the required new bit values and then rewrite this data back to the output ports.

Port A has the additional capability of providing wake-up functions. When the device is in the SLEEP or IDLE Mode, various methods are available to wake the device up. One of these is a high to low transition of any of the Port A pins. Single or multiple pins on Port A can be setup to have this function.

Timer Modules – TM

One of the most fundamental functions in any microcontroller devices is the ability to control and measure time. To implement time related functions the device includes several Timer Modules, generally abbreviated to the name TM. The TMs are multi-purpose timing units and serve to provide operations such as Timer/Counter, Input Capture, Compare Match Output and Single Pulse Output as well as being the functional unit for the generation of PWM signals. Each of the TMs has two interrupts. The addition of input and output pins for each TM ensures that users are provided with timing units with a wide and flexible range of features.

The common features of the different TM types are described here with more detailed information provided in the individual Compact and Periodic TM sections.

Introduction

These devices contain several TMs and each individual TM can be categorised as a certain type, namely Compact Type TM or Periodic Type TM. Although similar in nature, the different TM types vary in their feature complexity. The common features to all of the Compact and Periodic TMs will be described in this section and the detailed operation regarding each of the TM types will be described in separate sections. The main features and differences between the two types of TMs are summarised in the accompanying table.

TM Function	CTM	PTM
Timer/Counter	√	√
Input Capture	—	√
Compare Match Output	√	√
PWM Output	√	√
Single Pulse Output	—	√
PWM Alignment	Edge	Edge
PWM Adjustment Period & Duty	Duty or Period	Duty or Period

TM Function Summary

Device	CTM	PTM
BS86C08C BS86D12C	CTM0	PTM0
BS86E16C BS86D20C	CTM0	PTM0, PTM1

TM Name/Type Summary

TM Operation

The different types of TM offer a diverse range of functions, from simple timing operations to PWM signal generation. The key to understanding how the TM operates is to see it in terms of a free running count-up counter whose value is then compared with the value of pre-programmed internal comparators. When the free running count-up counter has the same value as the pre-programmed comparator, known as a compare match situation, a TM interrupt signal will be generated which can clear the counter and perhaps also change the condition of the TM output pin. The internal TM counter is driven by a user selectable clock source, which can be an internal clock or an external pin.

TM Clock Source

The clock source which drives the main counter in each TM can originate from various sources. The selection of the required clock source is implemented using the xTnCK2~xTnCK0 bits in the xTMn control registers, where “x” stands for C or P type TM and “n” stands for the specific TM

serial number. The clock source can be a ratio of the system clock, f_{SYS} , or the internal high clock, f_{H} , the f_{SUB} clock source or the external xTCKn pin. The xTCKn pin clock source is used to allow an external signal to drive the TM as an external clock source for event counting.

TM Interrupts

The Compact or Periodic type TM each has two internal interrupt, one for each of the internal comparator A or comparator P, which generate a TM interrupt when a compare match condition occurs. When a TM interrupt is generated, it can be used to clear the counter and also to change the state of the TM output pin.

TM External Pins

Each of the TMs, irrespective of what type, has one input pin with the label xTCKn while the Periodic TMs have another input pin with the label PTPnI. The xTMn input pin, xTCKn, is essentially a clock source for the xTMn and is selected using the xTnCK2~xTnCK0 bits in the xTMnC0 register. This external TM input pin allows an external clock source to drive the internal TM. The xTCKn input pin can be chosen to have either a rising or falling active edge. The PTCKn pins are also used as the external trigger input pin in single pulse output mode for the PTMn.

The other PTMn input pin, PTPnI, is the capture input whose active edge can be a rising edge, a falling edge or both rising and falling edges and the active edge transition type is selected using the PTnIO1~PTnIO0 bits in the PTMnC1 register. There is another capture input, PTCKn, for PTMn capture input mode, which can be used as the external trigger input source except the PTPnI pin.

The TMs each have two output pins, xTPn and xTPnB. The xTPnB pin outputs the inverted signal of the xTPn. When the TM is in the Compare Match Output Mode, these pins can be controlled by the TM to switch to a high or low level or to toggle when a compare match situation occurs. The external xTPn and xTPnB output pins are also the pins where the xTMn generates the PWM output waveform. As the xTMn output pins are pin-shared with other functions, the TM output function must first be setup using the relevant registers. A signal bit in the register determines if its associated pin is to be used as an external TM output pin or if it is to have another function. The number of external pins for each TM type is different, the details are provided in the accompanying table.

Device	CTM		PTM	
	Input	Output	Input	Output
BS86C08C BS86D12C	CTCK0	CTP0, CTP0B	PTCK0, PTP0I	PTP0, PTP0B
BS86E16C BS86D20C	CTCK0	CTP0, CTP0B	PTCK0, PTP0I PTCK1, PTP1I	PTP0, PTP0B PTP1, PTP1B

TM External Pins

TM Input/Output Pin Control Register

Selecting to have a TM input/output or whether to retain its other shared function is implemented using one register, with a single bit in the register corresponding to a TM input/output pin. Setting the bit high will setup the corresponding pin as a TM input/output, if reset to zero the pin will retain its original other function.

• **TMPC Register – BS86C08C/BS86D12C**

Bit	7	6	5	4	3	2	1	0
Name	VREFS	—	—	—	PTM0PC1	PTM0PC0	CTM0PC1	CTM0PC0
R/W	R/W	—	—	—	R/W	R/W	R/W	R/W
POR	0	—	—	—	0	0	0	0

- Bit 7 **VREFS**: VREF pin control
 0: Disable
 1: Enable
- Bit 6~4 Unimplemented, read as “0”
- Bit 3 **PTM0PC1**: PTP0B pin control
 0: Disable
 1: Enable
- Bit 2 **PTM0PC0**: PTP0 pin control
 0: Disable
 1: Enable
- Bit 1 **CTM0PC1**: CTP0B pin control
 0: Disable
 1: Enable
- Bit 0 **CTM0PC0**: CTP0 pin control
 0: Disable
 1: Enable

• **TMPC Register – BS86E16C/BS86D20C**

Bit	7	6	5	4	3	2	1	0
Name	VREFS	—	PTM1PC1	PTM1PC0	PTM0PC1	PTM0PC0	CTM0PC1	CTM0PC0
R/W	R/W	—	R/W	R/W	R/W	R/W	R/W	R/W
POR	0	—	0	0	0	0	0	0

- Bit 7 **VREFS**: VREF pin control
 0: Disable
 1: Enable
- Bit 6 Unimplemented, read as “0”
- Bit 5 **PTM1PC1**: PTP1B pin control
 0: Disable
 1: Enable
- Bit 4 **PTM1PC0**: PTP1 pin control
 0: Disable
 1: Enable
- Bit 3 **PTM0PC1**: PTP0B pin control
 0: Disable
 1: Enable
- Bit 2 **PTM0PC0**: PTP0 pin control
 0: Disable
 1: Enable
- Bit 1 **CTM0PC1**: CTP0B pin control
 0: Disable
 1: Enable
- Bit 0 **CTM0PC0**: CTP0 pin control
 0: Disable
 1: Enable

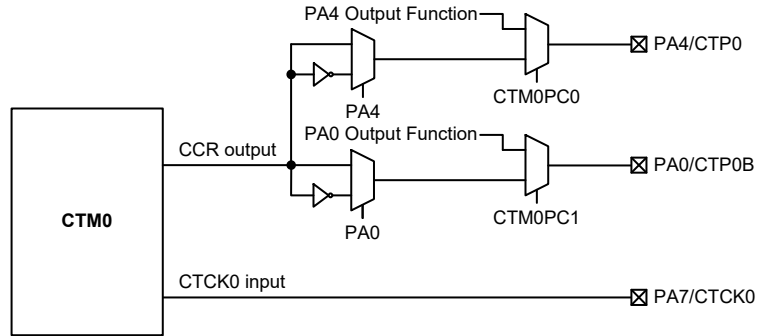

CTM0 Function Pin Control Block Diagram – BS86C08C/BS86D12C

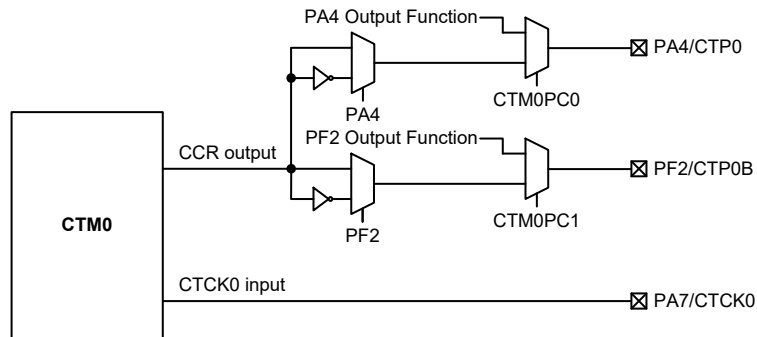

CTM0 Function Pin Control Block Diagram – BS86E16C

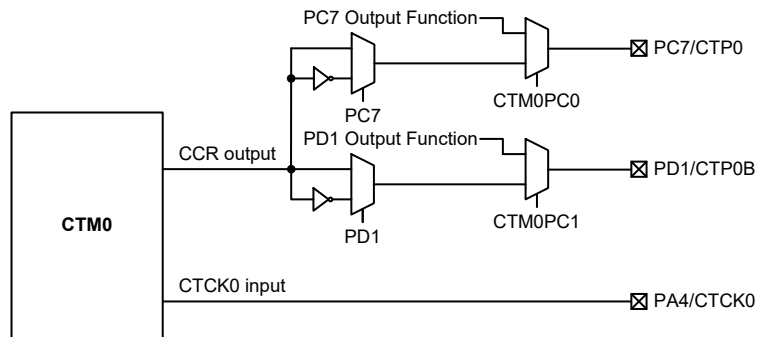

CTM0 Function Pin Control Block Diagram – BS86D20C

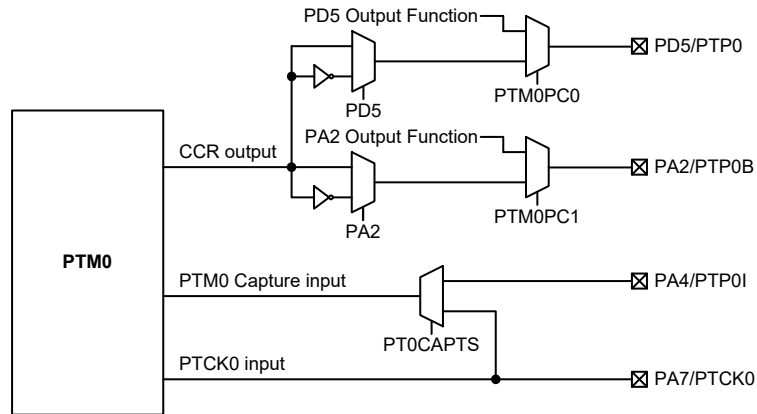

PTM0 Function Pin Control Block Diagram – BS86C08C/BS86D12C

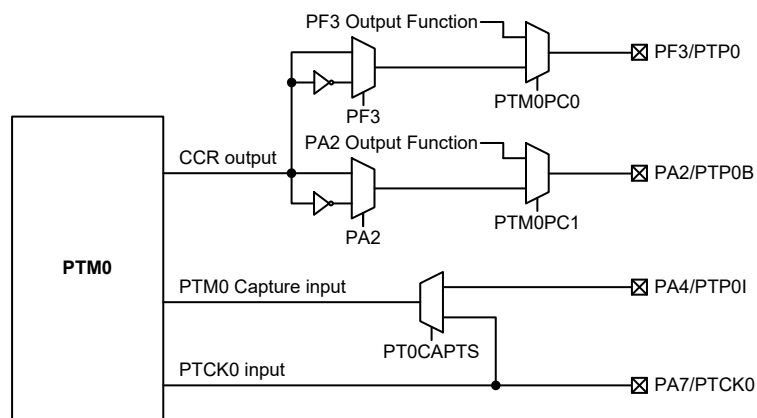

PTM0 Function Pin Control Block Diagram – BS86E16C

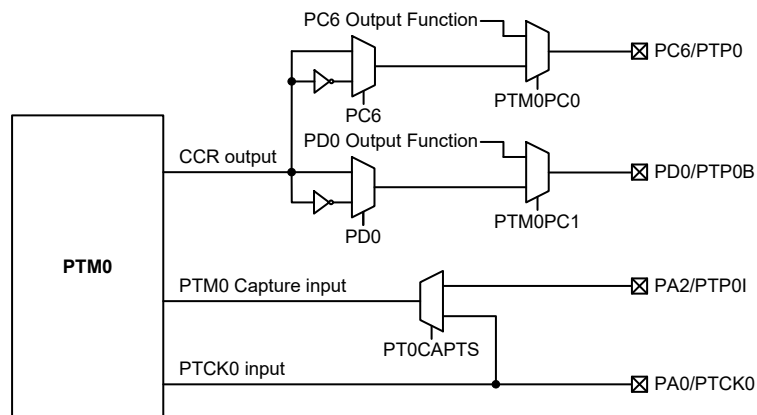

PTM0 Function Pin Control Block Diagram – BS86D20C

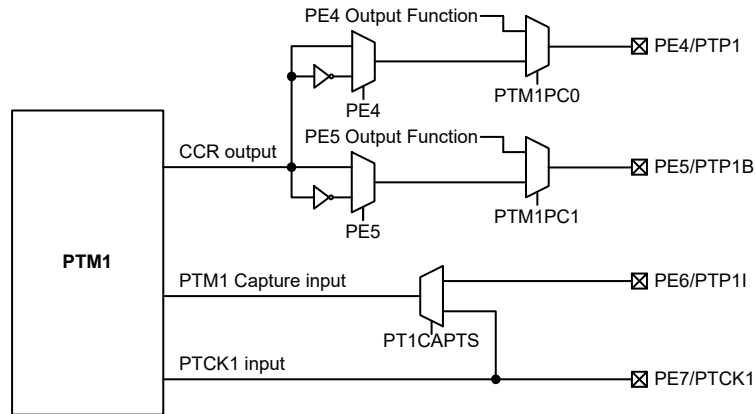

PTM1 Function Pin Control Block Diagram – BS86E16C

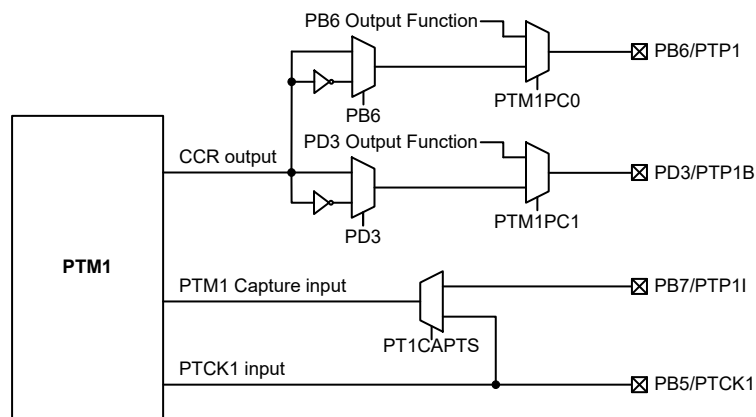

PTM1 Function Pin Control Block Diagram – BS86D20C

Programming Considerations

The TM Counter Registers and the Capture/Compare CCRA and CCRP registers, all have a low and high byte structure. The high bytes can be directly accessed, but as the low bytes can only be accessed via an internal 8-bit buffer, reading or writing to these register pairs must be carried out in a specific way. The important point to note is that data transfer to and from the 8-bit buffer and its related low byte only takes place when a write or read operation to its corresponding high byte is executed.

As the CCRA and CCRP registers are implemented in the way shown in the following diagram and accessing these register pairs is carried out in a specific way as described above, it is recommended to use the “MOV” instruction to access the CCRA and CCRP low byte registers, named xTMnAL and PTMnRPL, using the following access procedures. Accessing the CCRA or CCRP low byte registers without following these access procedures will result in unpredictable values.

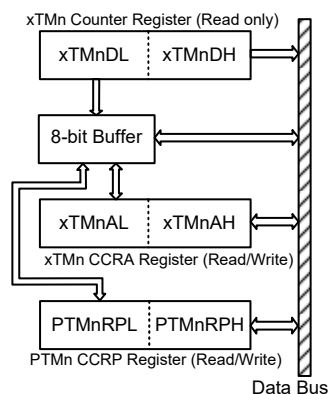

The following steps show the read and write procedures:

- Writing Data to CCRA or CCRP
 - ♦ Step 1. Write data to Low Byte xTMnAL or PTMnRPL
 - Note that here data is only written to the 8-bit buffer.
 - ♦ Step 2. Write data to High Byte xTMnAH or PTMnRPH
 - Here data is written directly to the high byte registers and simultaneously data is latched from the 8-bit buffer to the Low Byte registers.
- Reading Data from the Counter Registers and CCRA or CCRP
 - ♦ Step 1. Read data from the High Byte xTMnDH, xTMnAH or PTMnRPH
 - Here data is read directly from the High Byte registers and simultaneously data is latched from the Low Byte register into the 8-bit buffer.
 - ♦ Step 2. Read data from the Low Byte xTMnDL, xTMnAL or PTMnRPL
 - This step reads data from the 8-bit buffer.

Compact Type TM – CTM

The Compact Type TM contains three operating modes, which are Compare Match Output, Timer/Event Counter and PWM Output modes. The Compact TM can also be controlled with an external input pin and can drive two external output pins.

Device	CTM Core	CTM Input Pin	CTM Output Pin
BS86C08C BS86D12C BS86E16C BS86D20C	10-bit CTM (CTM0)	CTCK0	CTP0, CTP0B

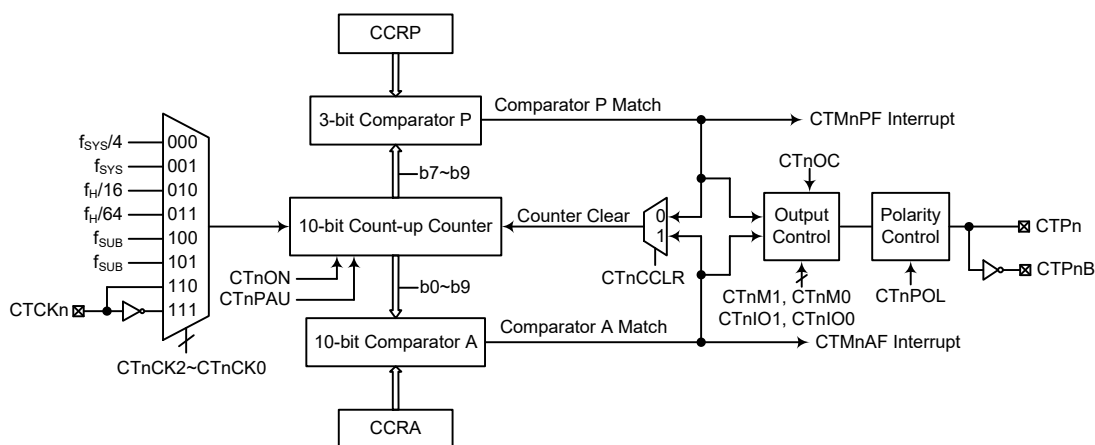

Note: The CTPnB pin outputs the inverted signal of the CTPn.

Compact Type TM Block Diagram (n=0)

Compact Type TM Operation

The size of Compact TM is 10-bit wide and its core is a 10-bit count-up counter which is driven by a user selectable internal or external clock source. There are also two internal comparators with the names, Comparator A and Comparator P. These comparators will compare the value in the counter with CCRP and CCRA registers. The CCRP comparator is 3-bit wide whose value is compared with the highest 3 bits in the counter while the CCRA is the 10 bits and therefore compares all counter bits.

The only way of changing the value of the 10-bit counter using the application program, is to clear the counter by changing the CTnON bit from low to high. The counter will also be cleared automatically by a counter overflow or a compare match with one of its associated comparators. When these conditions occur, a CTMn interrupt signal will also usually be generated. The Compact Type TM can operate in a number of different operational modes, can be driven by different clock sources including an input pin and can also control two output pins. All operating setup conditions are selected using relevant internal registers.

Compact Type TM Register Description

Overall operation of the Compact TM is controlled using a series of registers. A read only register pair exists to store the internal counter 10-bit value, while a read/write register pair exists to store the internal 10-bit CCRA value. The remaining two registers are control registers which setup the different operating and control modes as well as the CCRP bits.

Register Name	Bit							
	7	6	5	4	3	2	1	0
CTMnC0	CTnPAU	CTnCK2	CTnCK1	CTnCK0	CTnON	CTnRP2	CTnRP1	CTnRP0
CTMnC1	CTnM1	CTnM0	CTnIO1	CTnIO0	CTnOC	CTnPOL	CTnDPX	CTnCCLR
CTMnDL	D7	D6	D5	D4	D3	D2	D1	D0
CTMnDH	—	—	—	—	—	—	D9	D8
CTMnAL	D7	D6	D5	D4	D3	D2	D1	D0
CTMnAH	—	—	—	—	—	—	D9	D8

10-bit Compact Type TM Register List (n=0)

• **CTMnC0 Register**

Bit	7	6	5	4	3	2	1	0
Name	CTnPAU	CTnCK2	CTnCK1	CTnCK0	CTnON	CTnRP2	CTnRP1	CTnRP0
R/W	R/W	R/W	R/W	R/W	R/W	R/W	R/W	R/W
POR	0	0	0	0	0	0	0	0

Bit 7 **CTnPAU**: CTMn Counter Pause control
 0: Run
 1: Pause

The counter can be paused by setting this bit high. Clearing the bit to zero restores normal counter operation. When in a Pause condition the CTMn will remain powered up and continue to consume power. The counter will retain its residual value when this bit changes from low to high and resume counting from this value when the bit changes to a low value again.

Bit 6~4 **CTnCK2~CTnCK0**: Select CTMn Counter clock
 000: $f_{SYS}/4$
 001: f_{SYS}
 010: $f_H/16$
 011: $f_H/64$
 100: f_{SUB}
 101: f_{SUB}
 110: CTCKn rising edge clock
 111: CTCKn falling edge clock

These three bits are used to select the clock source for the CTMn. The external pin clock source can be chosen to be active on the rising or falling edge. The clock source f_{SYS} is the system clock, while f_H and f_{SUB} are other internal clocks, the details of which can be found in the oscillator section.

Bit 3 **CTnON**: CTMn Counter On/Off control
 0: Off
 1: On

This bit controls the overall on/off function of the CTMn. Setting the bit high enables the counter to run while clearing the bit disables the CTMn. Clearing this bit to zero will stop the counter from counting and turn off the CTMn which will reduce its power consumption. When the bit changes state from low to high the internal counter value will be reset to zero, however when the bit changes from high to low, the internal counter will retain its residual value until the bit returns high again. If the CTMn is in the Compare Match Output Mode or the PWM Output Mode then the CTMn output pin will be reset to its initial condition, as specified by the CTnOC bit, when the CTnON bit changes from low to high.

Bit 2~0 **CTnRP2~CTnRP0**: CTMn CCRP 3-bit register, compared with the CTMn counter bit 9 ~ bit 7
 Comparator P match period=
 0: 1024 CTMn clocks
 1~7: (1~7)×128 CTMn clocks

These three bits are used to setup the value on the internal CCRP 3-bit register, which are then compared with the internal counter's highest three bits. The result of this comparison can be selected to clear the internal counter if the CTnCCLR bit is set to zero. Setting the CTnCCLR bit to zero ensures that a compare match with the CCRP values will reset the internal counter. As the CCRP bits are only compared with the highest three counter bits, the compare values exist in 128 clock cycle multiples. Clearing all three bits to zero is in effect allowing the counter to overflow at its maximum value.

• **CTMnC1 Register**

Bit	7	6	5	4	3	2	1	0
Name	CTnM1	CTnM0	CTnIO1	CTnIO0	CTnOC	CTnPOL	CTnDPX	CTnCCLR
R/W	R/W	R/W	R/W	R/W	R/W	R/W	R/W	R/W
POR	0	0	0	0	0	0	0	0

Bit 7~6 **CTnM1~CTnM0**: Select CTMn Operating Mode
 00: Compare Match Output Mode
 01: Undefined
 10: PWM Output Mode
 11: Timer/Counter Mode

These bits setup the required operating mode for the CTMn. To ensure reliable operation the CTMn should be switched off before any changes are made to the CTnM1 and CTnM0 bits. In the Timer/Counter Mode, the CTMn output pin control will be disabled.

Bit 5~4 **CTnIO1~CTnIO0**: Select CTMn external pin CTPn function
 Compare Match Output Mode
 00: No change
 01: Output low
 10: Output high
 11: Toggle output

PWM Output Mode
 00: PWM output inactive state
 01: PWM output active state
 10: PWM output
 11: Undefined

Timer/Counter Mode
 Unused

These two bits are used to determine how the CTMn external pin changes state when a certain condition is reached. The function that these bits select depends upon in which mode the CTMn is running.

In the Compare Match Output Mode, the CTnIO1 and CTnIO0 bits determine how the CTMn output pin changes state when a compare match occurs from the Comparator A. The CTMn output pin can be setup to switch high, switch low or to toggle its present state when a compare match occurs from the Comparator A. When the bits are both zero, then no change will take place on the output. The initial value of the CTMn output pin should be setup using the CTnOC bit in the CTMnC1 register. Note that the output level requested by the CTnIO1 and CTnIO0 bits must be different from the initial value setup using the CTnOC bit otherwise no change will occur on the CTMn output pin when a compare match occurs. After the CTMn output pin changes state, it can be reset to its initial level by changing the level of the CTnON bit from low to high.

In the PWM Output Mode, the CTnIO1 and CTnIO0 bits determine how the CTMn output pin changes state when a certain compare match condition occurs. The PWM output function is modified by changing these two bits. It is necessary to only change the values of the CTnIO1 and CTnIO0 bits only after the CTMn has been switched off. Unpredictable PWM outputs will occur if the CTnIO1 and CTnIO0 bits are changed when the CTMn is running.

- Bit 3 **CTnOC**: CTMn CTPn Output control
Compare Match Output Mode
 0: Initial low
 1: Initial high
PWM Output Mode/Single Pulse Output Mode
 0: Active low
 1: Active high
This is the output control bit for the CTMn output pin. Its operation depends upon whether CTMn is being used in the Compare Match Output Mode or in the PWM Output Mode. It has no effect if the CTMn is in the Timer/Counter Mode. In the Compare Match Output Mode it determines the logic level of the CTMn output pin before a compare match occurs. In the PWM Output Mode it determines if the PWM signal is active high or active low.
- Bit 2 **CTnPOL**: CTMn CTPn Output polarity control
 0: Non-invert
 1: Invert
This bit controls the polarity of the CTPn output pin. When the bit is set high the CTMn output pin will be inverted and not inverted when the bit is zero. It has no effect if the CTMn is in the Timer/Counter Mode.
- Bit 1 **CTnDPX**: CTMn PWM duty/period control
 0: CCRP – period; CCRA – duty
 1: CCRP – duty; CCRA – period
This bit determines which of the CCRA and CCRP registers are used for period and duty control of the PWM waveform.
- Bit 0 **CTnCCLR**: CTMn Counter Clear condition selection
 0: Comparator P match
 1: Comparator A match
This bit is used to select the method which clears the counter. Remember that the CTMn contains two comparators, Comparator A and Comparator P, either of which can be selected to clear the internal counter. With the CTnCCLR bit set high, the counter will be cleared when a compare match occurs from the Comparator A. When the bit is low, the counter will be cleared when a compare match occurs from the Comparator P or with a counter overflow. A counter overflow clearing method can only be implemented if the CCRP bits are all cleared to zero. The CTnCCLR bit is not used in the PWM Output mode.

• **CTMnDL Register**

Bit	7	6	5	4	3	2	1	0
Name	D7	D6	D5	D4	D3	D2	D1	D0
R/W	R	R	R	R	R	R	R	R
POR	0	0	0	0	0	0	0	0

Bit 7~0 **D7~D0**: CTMn Counter Low Byte Register bit 7 ~ bit 0
CTMn 10-bit Counter bit 7 ~ bit 0

• **CTMnDH Register**

Bit	7	6	5	4	3	2	1	0
Name	—	—	—	—	—	—	D9	D8
R/W	—	—	—	—	—	—	R	R
POR	—	—	—	—	—	—	0	0

Bit 7~2 Unimplemented, read as “0”
Bit 1~0 **D9~D8**: CTMn Counter High Byte Register bit 1 ~ bit 0
CTMn 10-bit Counter bit 9 ~ bit 8

• **CTMnAL Register**

Bit	7	6	5	4	3	2	1	0
Name	D7	D6	D5	D4	D3	D2	D1	D0
R/W	R/W	R/W	R/W	R/W	R/W	R/W	R/W	R/W
POR	0	0	0	0	0	0	0	0

Bit 7~0 **D7~D0**: CTMn CCRA Low Byte Register bit 7 ~ bit 0
CTMn 10-bit CCRA bit 7 ~ bit 0

• **CTMnAH Register**

Bit	7	6	5	4	3	2	1	0
Name	—	—	—	—	—	—	D9	D8
R/W	—	—	—	—	—	—	R/W	R/W
POR	—	—	—	—	—	—	0	0

Bit 7~2 Unimplemented, read as “0”
Bit 1~0 **D9~D8**: CTMn CCRA High Byte Register bit 7 ~ bit 0
CTMn 10-bit CCRA bit 9 ~ bit 8

Compact Type TM Operation Modes

The Compact Type TM can operate in one of three operating modes, Compare Match Output Mode, PWM Output Mode or Timer/Counter Mode. The operating mode is selected using the CTnM1 and CTnM0 bits in the CTMnC1 register.

Compare Match Output Mode

To select this mode, bits CTnM1 and CTnM0 in the CTMnC1 register, should be set to 00 respectively. In this mode once the counter is enabled and running it can be cleared by three methods. These are a counter overflow, a compare match from Comparator A and a compare match from Comparator P. When the CTnCCLR bit is low, there are two ways in which the counter can be cleared. One is when a compare match from Comparator P, the other is when the CCRP bits are all zero which allows the counter to overflow. Here both CTMnAF and CTMnPF interrupt request flags for Comparator A and Comparator P respectively, will both be generated.

If the CTnCCLR bit in the CTMnC1 register is high then the counter will be cleared when a compare match occurs from Comparator A. However, here only the CTMnAF interrupt request flag will be generated even if the value of the CCRP bits is less than that of the CCRA registers. Therefore when CTnCCLR is high no CTMnPF interrupt request flag will be generated. If the CCRA bits are all zero, the counter will overflow when it reaches its maximum 10-bit, 3FF Hex, value. However, here the CTMnAF interrupt request flag will not be generated.

As the name of the mode suggests, after a comparison is made, the CTMn output pin, will change state. The CTMn output pin condition however only changes state when a CTMnAF interrupt request flag is generated after a compare match occurs from Comparator A. The CTMnPF interrupt request flag, generated from a compare match occurs from Comparator P, will have no effect on the CTMn output pin. The way in which the CTMn output pin changes state are determined by the condition of the CTnIO1 and CTnIO0 bits in the CTMnC1 register. The CTMn output pin can be selected using the CTnIO1 and CTnIO0 bits to go high, to go low or to toggle from its present condition when a compare match occurs from Comparator A. The initial condition of the CTMn output pin, which is setup after the CTnON bit changes from low to high, is setup using the CTnOC bit. Note that if the CTnIO1 and CTnIO0 bits are zero then no pin change will take place.

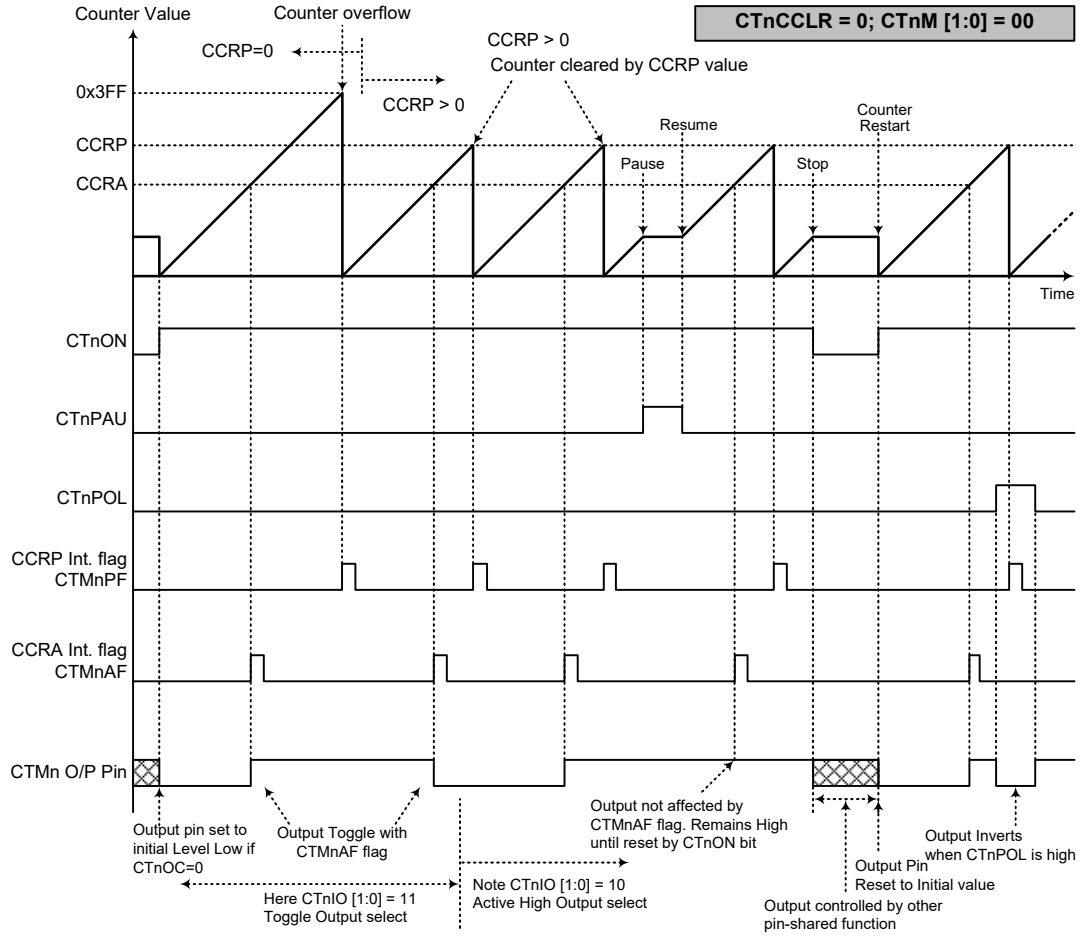

Compare Match Output Mode – $CTnCCR=0$ ($n=0$)

- Note: 1. With $CTnCCR=0$ a Comparator P match will clear the counter
 2. The CTMn output pin is controlled only by the CTMnAF flag
 3. The output pin is reset to its initial state by a CTnON bit rising edge

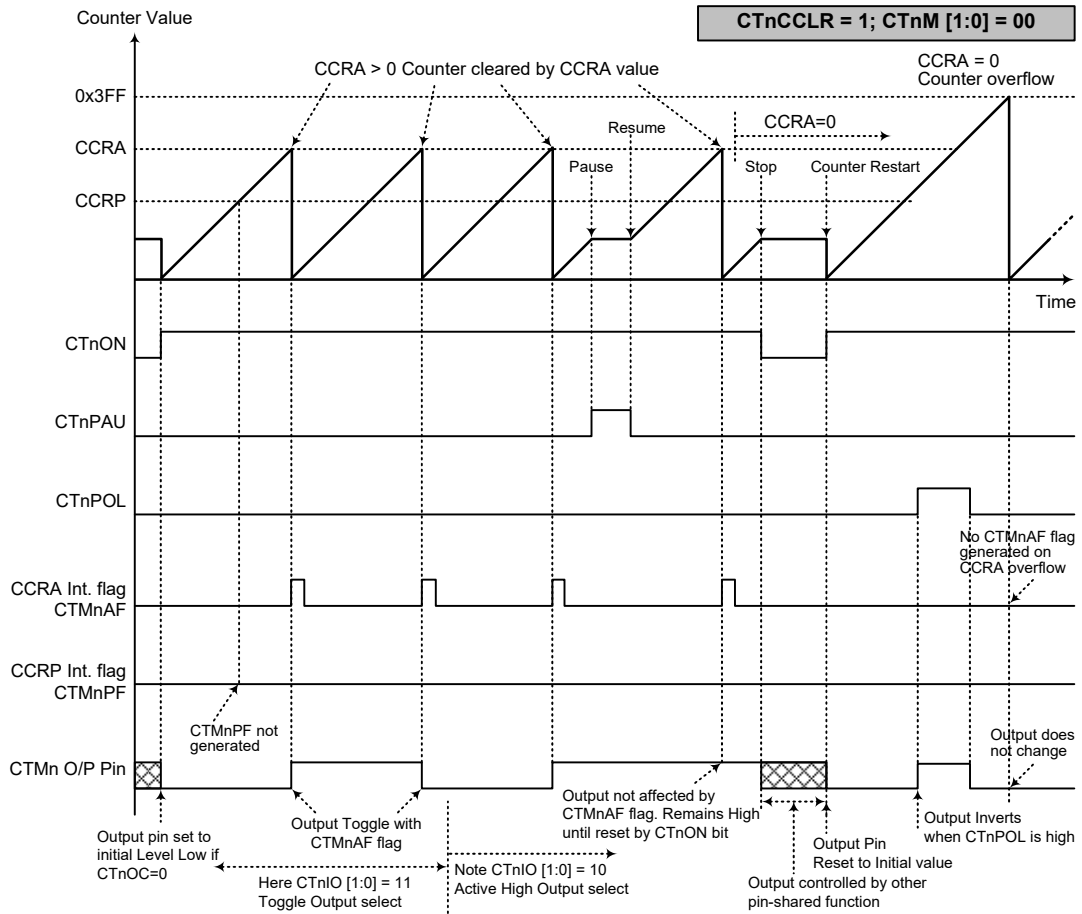

Compare Match Output Mode – CTnCCR=1 (n=0)

- Note: 1. With CTnCCR=1 a Comparator A match will clear the counter
 2. The CTMn output pin is controlled only by the CTMnAF flag
 3. The output pin is reset to its initial state by a CTnON bit rising edge
 4. A CTMnPF flag is not generated when CTnCCR=1

Timer/Counter Mode

To select this mode, bits CTnM1 and CTnM0 in the CTMnC1 register should be set to 11 respectively. The Timer/Counter Mode operates in an identical way to the Compare Match Output Mode generating the same interrupt flags. The exception is that in the Timer/Counter Mode the CTMn output pin is not used. Therefore the above description and Timing Diagrams for the Compare Match Output Mode can be used to understand its function. As the CTMn output pin is not used in this mode, the pin can be used as a normal I/O pin or other pin-shared function.

PWM Output Mode

To select this mode, bits CTnM1 and CTnM0 in the CTMnC1 register should be set to 10 respectively. The PWM function within the CTMn is useful for applications which require functions such as motor control, heating control, illumination control, etc. By providing a signal of fixed frequency but of varying duty cycle on the CTMn output pin, a square wave AC waveform can be generated with varying equivalent DC RMS values.

As both the period and duty cycle of the PWM waveform can be controlled, the choice of generated waveform is extremely flexible. In the PWM Output Mode, the CTnCCLR bit has no effect as the PWM period. Both of the CCRA and CCRP registers are used to generate the PWM waveform, one register is used to clear the internal counter and thus control the PWM waveform frequency, while the other one is used to control the duty cycle. Which register is used to control either frequency or duty cycle is determined using the CTnDPX bit in the CTMnC1 register. The PWM waveform frequency and duty cycle can therefore be controlled by the values in the CCRA and CCRP registers.

An interrupt flag, one for each of the CCRA and CCRP, will be generated when a compare match occurs from either Comparator A or Comparator P. The CTnOC bit in the CTMnC1 register is used to select the required polarity of the PWM waveform while the two CTnIO1 and CTnIO0 bits are used to enable the PWM output or to force the CTMn output pin to a fixed high or low level. The CTnPOL bit is used to reverse the polarity of the PWM output waveform.

• **10-bit CTMn, PWM Output Mode, Edge-aligned Mode, CTnDPX=0**

CCRP	1~7	0
Period	CCRP×128	1024
Duty	CCRA	

If $f_{SYS}=16\text{MHz}$, CTMn clock source is $f_{SYS}/4$, CCRP=4 and CCRA=128,

The CTMn PWM output frequency= $(f_{SYS}/4)/(4\times 128)=f_{SYS}/2048=8\text{kHz}$, duty= $128/(4\times 128)=25\%$.

If the Duty value defined by the CCRA register is equal to or greater than the Period value, then the PWM output duty is 100%.

• **10-bit CTMn, PWM Output Mode, Edge-aligned Mode, CTnDPX=1**

CCRP	1~7	0
Period	CCRA	
Duty	CCRP×128	1024

The PWM output period is determined by the CCRA register value together with the CTMn clock while the PWM duty cycle is defined by the CCRP register value except when the CCRP value is equal to 0.

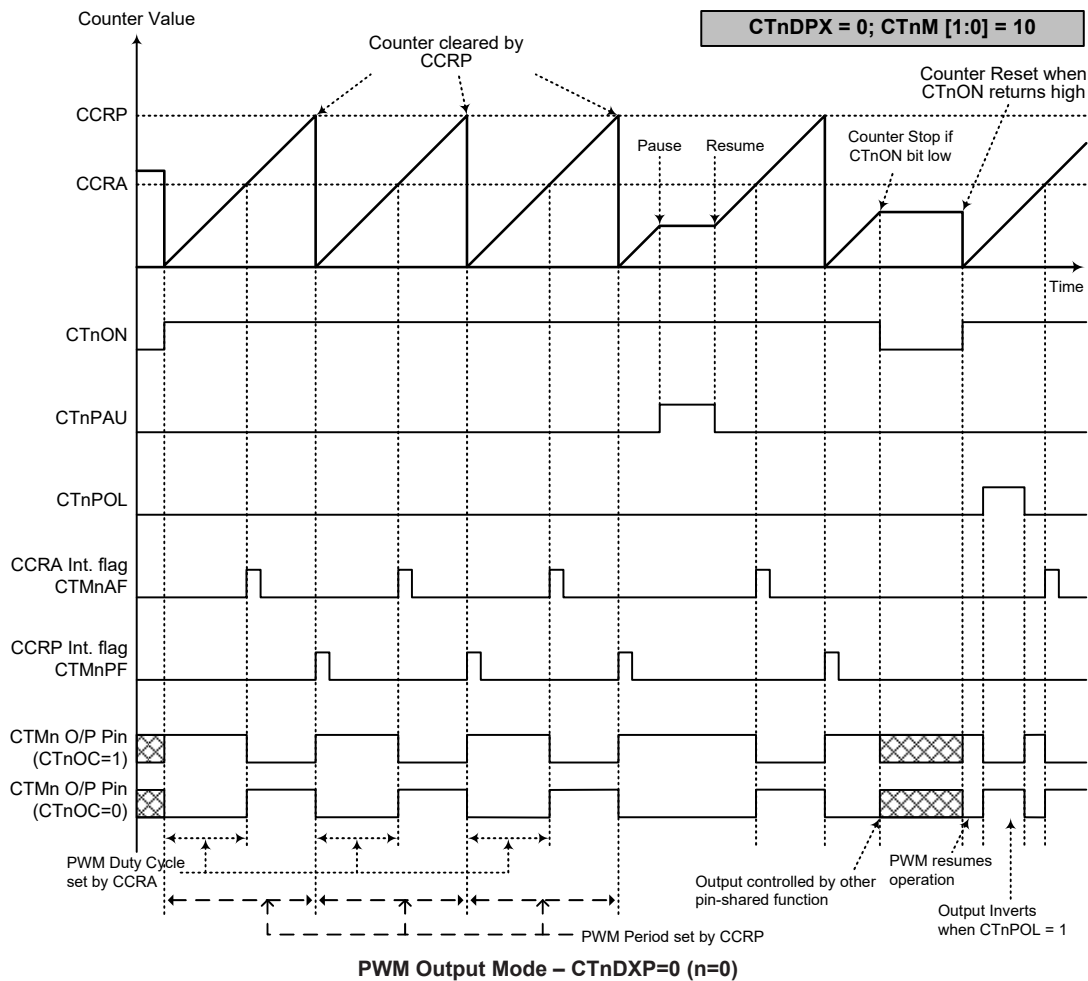

- Note: 1. Here CTnDPX=0 – Counter cleared by CCRP
 2. A counter clear sets the PWM Period
 3. The internal PWM function continues running even when CTnIO[1:0]=00 or 01
 4. The CTnCCLR bit has no influence on PWM operation

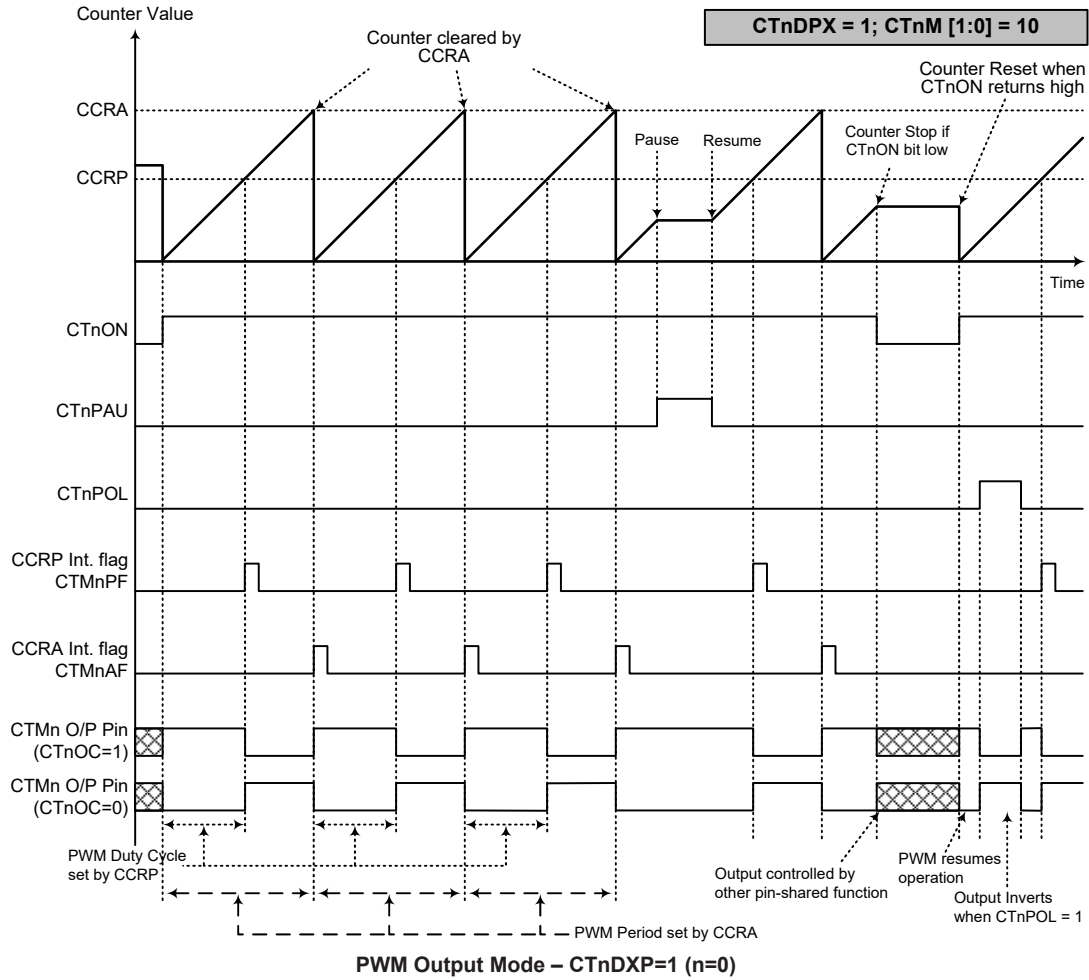

- Note: 1. Here CTnDPX=1 – Counter cleared by CCRA
 2. A counter clear sets the PWM Period
 3. The internal PWM function continues even when CTnIO[1:0]=00 or 01
 4. The CTnCLLR bit has no influence on PWM operation

Periodic Type TM – PTM

The Periodic Type TM contains five operating modes, which are Compare Match Output, Timer/Event Counter, Capture Input, Single Pulse Output and PWM Output modes. The Periodic TM can also be controlled with two external input pins and can drive two external output pins.

Device	PTM Core	PTM Input Pin	PTM Output Pin
BS86C08C BS86D12C	10-bit PTM (PTM0)	PTCK0, PTP0I	PTP0, PTP0B
BS86E16C BS86D20C	10-bit PTM (PTM0, PTM1)	PTCK0, PTP0I PTCK1, PTP1I	PTP0, PTP0B PTP1, PTP1B

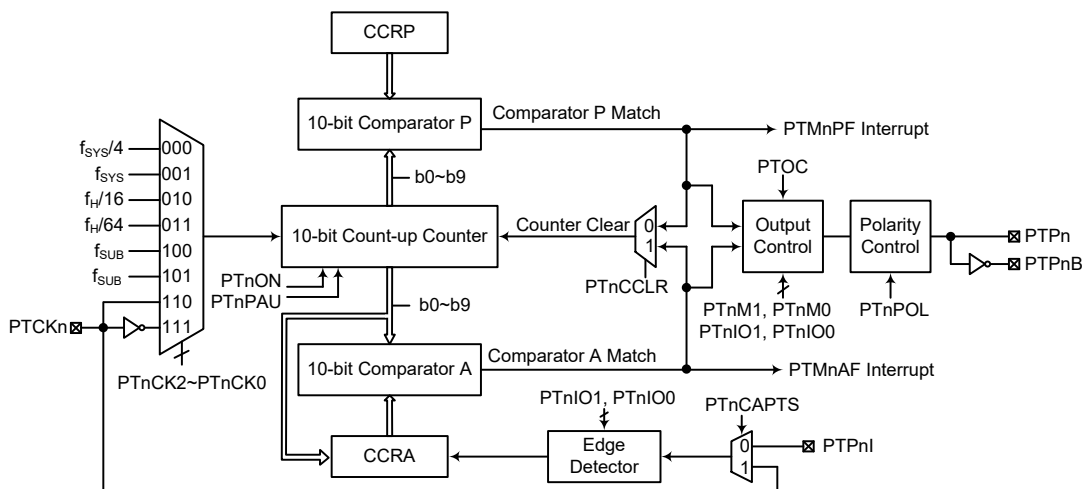

Note: The PTPnB pin outputs the inverted signal of the PTPn.

Periodic Type TM Block Diagram (n=0~1)

Periodic TM Operation

The size of Periodic TM is 10-bit wide and its core is a 10-bit count-up counter which is driven by a user selectable internal or external clock source. There are also two internal comparators with the names, Comparator A and Comparator P. These comparators will compare the value in the counter with CCRP and CCRA registers. The CCRP and CCRA comparators are 10-bit wide whose value is respectively compared with all counter bits.

The only way of changing the value of the 10-bit counter using the application program is to clear the counter by changing the PTnON bit from low to high. The counter will also be cleared automatically by a counter overflow or a compare match with one of its associated comparators. When these conditions occur, a PTMn interrupt signal will also usually be generated. The Periodic Type TM can operate in a number of different operational modes, can be driven by different clock sources including an input pin and can also control the output pins. All operating setup conditions are selected using relevant internal registers.

Periodic Type TM Register Description

Overall operation of the Periodic TM is controlled using a series of registers. A read only register pair exists to store the internal counter 10-bit value, while two read/write register pairs exist to store the internal 10-bit CCRA and CCRP value. The remaining two registers are control registers which setup the different operating and control modes.

Register Name	Bit							
	7	6	5	4	3	2	1	0
PTMnC0	PTnPAU	PTnCK2	PTnCK1	PTnCK0	PTnON	—	—	—
PTMnC1	PTnM1	PTnM0	PTnIO1	PTnIO0	PTnOC	PTnPOL	PTnCAPTS	PTnCCLR
PTMnDL	D7	D6	D5	D4	D3	D2	D1	D0
PTMnDH	—	—	—	—	—	—	D9	D8
PTMnAL	D7	D6	D5	D4	D3	D2	D1	D0
PTMnAH	—	—	—	—	—	—	D9	D8
PTMnRPL	PTnRP7	PTnRP6	PTnRP5	PTnRP4	PTnRP3	PTnRP2	PTnRP1	PTnRP0
PTMnRPH	—	—	—	—	—	—	PTnRP9	PTnRP8

10-bit Periodic TM Register List (n=0~1)

• **PTMnC0 Register**

Bit	7	6	5	4	3	2	1	0
Name	PTnPAU	PTnCK2	PTnCK1	PTnCK0	PTnON	—	—	—
R/W	R/W	R/W	R/W	R/W	R/W	—	—	—
POR	0	0	0	0	0	—	—	—

Bit 7 **PTnPAU**: PTMn Counter Pause control
 0: Run
 1: Pause

The counter can be paused by setting this bit high. Clearing the bit to zero restores normal counter operation. When in a Pause condition the PTMn will remain powered up and continue to consume power. The counter will retain its residual value when this bit changes from low to high and resume counting from this value when the bit changes to a low value again.

Bit 6~4 **PTnCK2~PTnCK0**: Select PTMn Counter clock
 000: $f_{SYS}/4$
 001: f_{SYS}
 010: $f_H/16$
 011: $f_H/64$
 100: f_{SUB}
 101: f_{SUB}
 110: PTCKn rising edge clock
 111: PTCKn falling edge clock

These three bits are used to select the clock source for the PTMn. The external pin clock source can be chosen to be active on the rising or falling edge. The clock source f_{SYS} is the system clock, while f_H and f_{SUB} are other internal clocks, the details of which can be found in the oscillator section.

Bit 3 **PTnON**: PTMn Counter On/Off control
 0: Off
 1: On

This bit controls the overall on/off function of the PTMn. Setting the bit high enables the counter to run while clearing the bit disables the PTMn. Clearing this bit to zero will stop the counter from counting and turn off the PTMn which will reduce its power consumption. When the bit changes state from low to high the internal counter value will be reset to zero, however when the bit changes from high to low, the internal counter will retain its residual value until the bit returns high again. If the PTMn is in the Compare Match Output Mode, PWM output Mode or Single Pulse Output Mode then the PTMn output pin will be reset to its initial condition, as specified by the PTnOC bit, when the PTnON bit changes from low to high.

Bit 2~0 Unimplemented, read as “0”

• **PTMnC1 Register**

Bit	7	6	5	4	3	2	1	0
Name	PTnM1	PTnM0	PTnIO1	PTnIO0	PTnOC	PTnPOL	PTnCAPTS	PTnCCLR
R/W	R/W	R/W	R/W	R/W	R/W	R/W	R/W	R/W
POR	0	0	0	0	0	0	0	0

Bit 7~6 **PTnM1~PTnM0**: Select PTMn Operating Mode
 00: Compare Match Output Mode
 01: Capture Input Mode
 10: PWM Output Mode or Single Pulse Output Mode
 11: Timer/Counter Mode

These bits setup the required operating mode for the PTMn. To ensure reliable operation the PTMn should be switched off before any changes are made to the PTnM1 and PTnM0 bits. In the Timer/Counter Mode, the PTMn output pin control will be disabled.

Bit 5~4 **PTnIO1~PTnIO0**: Select PTMn external pin PTPn, PTPnI or PTCKn function

Compare Match Output Mode

- 00: No change
- 01: Output low
- 10: Output high
- 11: Toggle output

PWM Output Mode/Single Pulse Output Mode

- 00: PWM output inactive state
- 01: PWM output active state
- 10: PWM output
- 11: Single Pulse Output

Capture Input Mode

- 00: Input capture at rising edge of PTPnI or PTCKn
- 01: Input capture at falling edge of PTPnI or PTCKn
- 10: Input capture at rising/falling edge of PTPnI or PTCKn
- 11: Input capture disabled

Timer/Counter Mode

Unused

These two bits are used to determine how the PTMn external pin changes state when a certain condition is reached. The function that these bits select depends upon in which mode the PTMn is running.

In the Compare Match Output Mode, the PTnIO1 and PTnIO0 bits determine how the PTMn output pin changes state when a compare match occurs from the Comparator A. The PTMn output pin can be setup to switch high, switch low or to toggle its present state when a compare match occurs from the Comparator A. When the bits are both zero, then no change will take place on the output. The initial value of the PTMn output pin should be setup using the PTnOC bit in the PTMnC1 register. Note that the output level requested by the PTnIO1 and PTnIO0 bits must be different from the initial value setup using the PTnOC bit otherwise no change will occur on the PTMn output pin when a compare match occurs. After the PTMn output pin changes state, it can be reset to its initial level by changing the level of the PTnON bit from low to high.

In the PWM Output Mode, the PTnIO1 and PTnIO0 bits determine how the TM output pin changes state when a certain compare match condition occurs. The PTMn output function is modified by changing these two bits. It is necessary to only change the values of the PTnIO1 and PTnIO0 bits only after the PTMn has been switched off. Unpredictable PWM outputs will occur if the PTnIO1 and PTnIO0 bits are changed when the PTMn is running.

- Bit 3 **PTnOC**: PTMn PTPn Output control
 Compare Match Output Mode
 0: Initial low
 1: Initial high
 PWM Output Mode/Single Pulse Output Mode
 0: Active low
 1: Active high

This is the output control bit for the PTMn output pin. Its operation depends upon whether PTMn is being used in the Compare Match Output Mode or in the PWM Output Mode/Single Pulse Output Mode. It has no effect if the PTMn is in the Timer/Counter Mode. In the Compare Match Output Mode it determines the logic level of the PTMn output pin before a compare match occurs. In the PWM Output Mode it determines if the PWM signal is active high or active low. In the Single Pulse Output Mode it determines the logic level of the PTMn output pin when the PTnON bit changes from low to high.

- Bit 2 **PTnPOL**: PTMn PTPn Output polarity control
 0: Non-invert
 1: Invert

This bit controls the polarity of the PTPn output pin. When the bit is set high the PTMn output pin will be inverted and not inverted when the bit is zero. It has no effect if the PTMn is in the Timer/Counter Mode.

- Bit 1 **PTnCAPTS**: PTMn Capture Trigger Source selection
 0: From PTPnI pin
 1: From PTCKn pin

- Bit 0 **PTnCCLR**: PTMn Counter Clear condition selection
 0: Comparator P match
 1: Comparator A match

This bit is used to select the method which clears the counter. Remember that the Periodic TM contains two comparators, Comparator A and Comparator P, either of which can be selected to clear the internal counter. With the PTnCCLR bit set high, the counter will be cleared when a compare match occurs from the Comparator A. When the bit is low, the counter will be cleared when a compare match occurs from the Comparator P or with a counter overflow. A counter overflow clearing method can only be implemented if the CCRP bits are all cleared to zero. The PTnCCLR bit is not used in the PWM Output, Single Pulse Output or Capture Input Mode.

• **PTMnDL Register**

Bit	7	6	5	4	3	2	1	0
Name	D7	D6	D5	D4	D3	D2	D1	D0
R/W	R	R	R	R	R	R	R	R
POR	0	0	0	0	0	0	0	0

- Bit 7~0 **D7~D0**: PTMn Counter Low Byte Register bit 7 ~ bit 0
 PTMn 10-bit Counter bit 7 ~ bit 0

• **PTMnDH Register**

Bit	7	6	5	4	3	2	1	0
Name	—	—	—	—	—	—	D9	D8
R/W	—	—	—	—	—	—	R	R
POR	—	—	—	—	—	—	0	0

- Bit 7~2 Unimplemented, read as “0”
 Bit 1~0 **D9~D8**: PTMn Counter High Byte Register bit 1 ~ bit 0
 PTMn 10-bit Counter bit 9 ~ bit 8

• **PTMnAL Register**

Bit	7	6	5	4	3	2	1	0
Name	D7	D6	D5	D4	D3	D2	D1	D0
R/W	R/W	R/W	R/W	R/W	R/W	R/W	R/W	R/W
POR	0	0	0	0	0	0	0	0

Bit 7~0 **D7~D0**: PTMn CCRA Low Byte Register bit 7 ~ bit 0
 PTMn 10-bit CCRA bit 7 ~ bit 0

• **PTMnAH Register**

Bit	7	6	5	4	3	2	1	0
Name	—	—	—	—	—	—	D9	D8
R/W	—	—	—	—	—	—	R/W	R/W
POR	—	—	—	—	—	—	0	0

Bit 7~2 Unimplemented, read as “0”
 Bit 1~0 **D9~D8**: PTMn CCRA High Byte Register bit 1 ~ bit 0
 PTMn 10-bit CCRA bit 9 ~ bit 8

• **PTMnRPL Register**

Bit	7	6	5	4	3	2	1	0
Name	PTnRP7	PTnRP6	PTnRP5	PTnRP4	PTnRP3	PTnRP2	PTnRP1	PTnRP0
R/W	R/W	R/W	R/W	R/W	R/W	R/W	R/W	R/W
POR	0	0	0	0	0	0	0	0

Bit 7~0 **PTnRP7~PTnRP0**: PTMn CCRP Low Byte Register bit 7 ~ bit 0
 PTMn 10-bit CCRP bit 7 ~ bit 0

• **PTMnRPH Register**

Bit	7	6	5	4	3	2	1	0
Name	—	—	—	—	—	—	PTnRP9	PTnRP8
R/W	—	—	—	—	—	—	R/W	R/W
POR	—	—	—	—	—	—	0	0

Bit 7~2 Unimplemented, read as “0”
 Bit 1~0 **PTnRP9~PTnRP8**: PTMn CCRP High Byte Register bit 1 ~ bit 0
 PTMn 10-bit CCRP bit 9 ~ bit 8

Periodic Type TM Operation Modes

The Periodic Type TM can operate in one of five operating modes, Compare Match Output Mode, PWM Output Mode, Single Pulse Output Mode, Capture Input Mode or Timer/Counter Mode. The operating mode is selected using the PTnM1 and PTnM0 bits in the PTMnC1 register.

Compare Match Output Mode

To select this mode, bits PTnM1 and PTnM0 in the PTMnC1 register, should be set to 00 respectively. In this mode once the counter is enabled and running it can be cleared by three methods. These are a counter overflow, a compare match from Comparator A and a compare match from Comparator P. When the PTnCCLR bit is low, there are two ways in which the counter can be cleared. One is when a compare match from Comparator P, the other is when the CCRP bits are all zero which allows the counter to overflow. Here both PTMnAF and PTMnPF interrupt request flags for Comparator A and Comparator P respectively, will both be generated.

If the PTnCCLR bit in the PTMnC1 register is high then the counter will be cleared when a compare match occurs from Comparator A. However, here only the PTMnAF interrupt request flag will be generated even if the value of the CCRP bits is less than that of the CCRA registers. Therefore when PTnCCLR is high no PTMnPF interrupt request flag will be generated. In the Compare Match Output Mode, the CCRA cannot be cleared to zero. If the CCRA bits are all zero, the counter will overflow when it reaches its maximum 10-bit, 3FF Hex, value, however here the PTMnAF interrupt request flag will not be generated.

As the name of the mode suggests, after a comparison is made, the PTMn output pin will change state. The PTMn output pin condition however only changes state when a PTMnAF interrupt request flag is generated after a compare match occurs from Comparator A. The PTMnPF interrupt request flag, generated from a compare match occurs from Comparator P, will have no effect on the PTMn output pin. The way in which the PTMn output pin changes state are determined by the condition of the PTnIO1 and PTnIO0 bits in the PTMnC1 register. The PTMn output pin can be selected using the PTnIO1 and PTnIO0 bits to go high, to go low or to toggle from its present condition when a compare match occurs from Comparator A. The initial condition of the PTMn output pin, which is setup after the PTnON bit changes from low to high, is setup using the PTnOC bit. Note that if the PTnIO1 and PTnIO0 bits are zero then no pin change will take place.

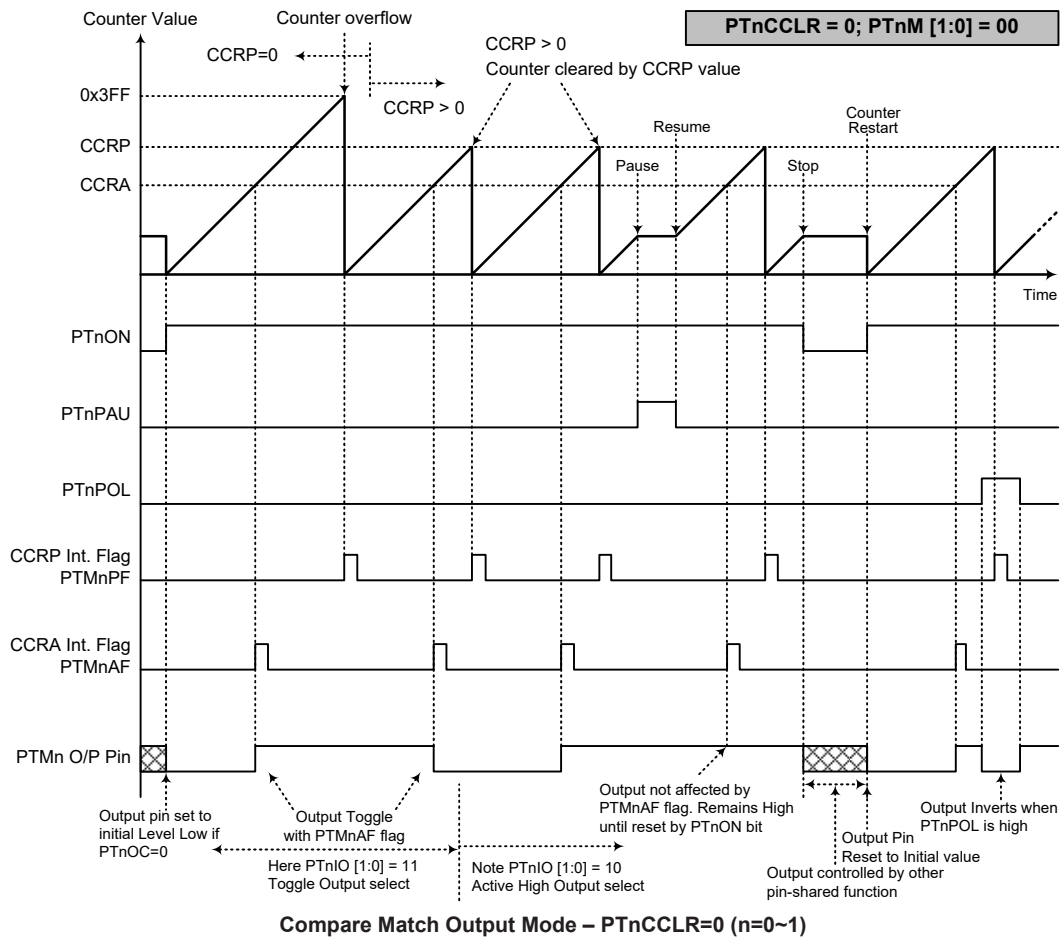

- Note: 1. With PTnCCR=0, a Comparator P match will clear the counter
 2. The PTMn output pin is controlled only by the PTMnAF flag
 3. The output pin is reset to its initial state by a PTnON bit rising edge

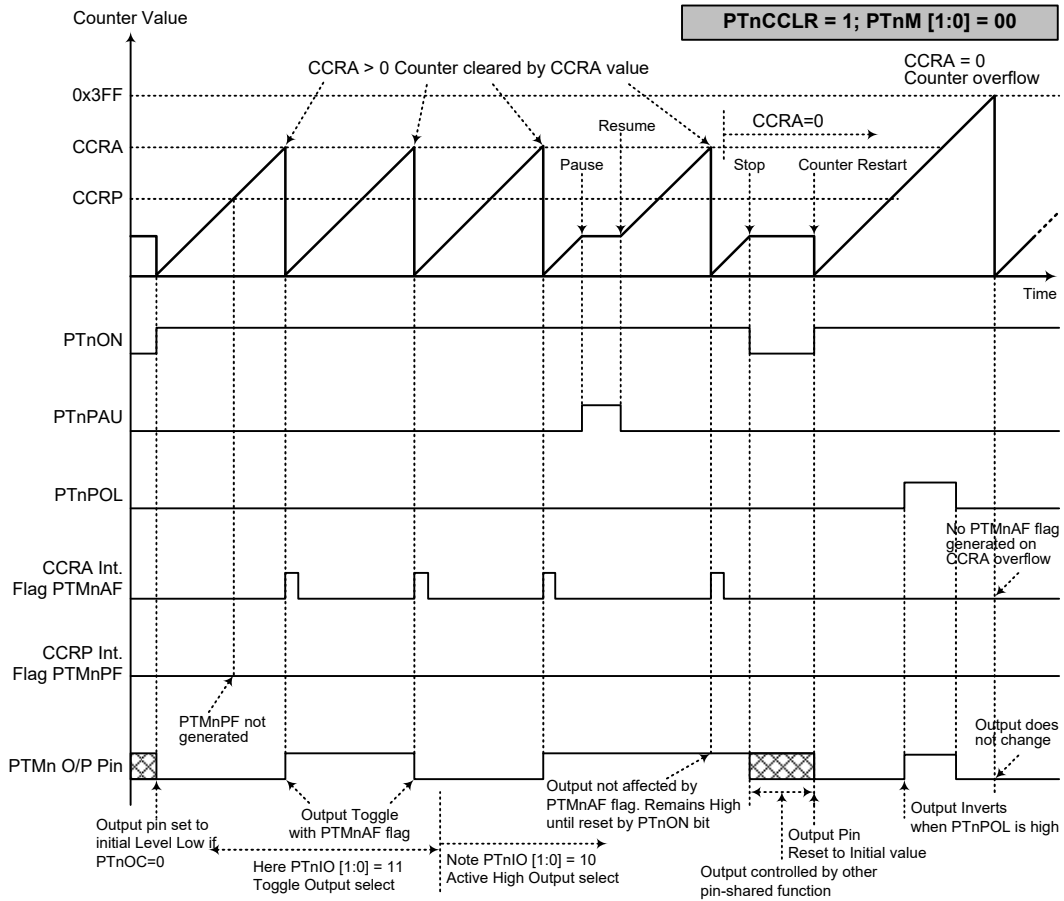

Compare Match Output Mode – PTnCCR=1 (n=0~1)

- Note: 1. With PTnCCR=1, a Comparator A match will clear the counter
 2. The PTMn output pin is controlled only by the PTMnAF flag
 3. The output pin is reset to its initial state by a PTnON bit rising edge
 4. A PTMnPF flag is not generated when PTnCCR=1

Timer/Counter Mode

To select this mode, bits PTnM1 and PTnM0 in the PTMnC1 register should be set to 11 respectively. The Timer/Counter Mode operates in an identical way to the Compare Match Output Mode generating the same interrupt flags. The exception is that in the Timer/Counter Mode the PTMn output pin is not used. Therefore the above description and Timing Diagrams for the Compare Match Output Mode can be used to understand its function. As the PTMn output pin is not used in this mode, the pin can be used as a normal I/O pin or other pin-shared function.

PWM Output Mode

To select this mode, bits PTnM1 and PTnM0 in the PTMnC1 register should be set to 10 respectively and also the PTnIO1 and PTnIO0 bits should be set to 10 respectively. The PWM function within the PTMn is useful for applications which require functions such as motor control, heating control, illumination control, etc. By providing a signal of fixed frequency but of varying duty cycle on the PTMn output pin, a square wave AC waveform can be generated with varying equivalent DC RMS values.

As both the period and duty cycle of the PWM waveform can be controlled, the choice of generated waveform is extremely flexible. In the PWM Output Mode, the PTnCCLR bit has no effect as the PWM period. Both of the CCRP and CCRA registers are used to generate the PWM waveform, one register is used to clear the internal counter and thus control the PWM waveform frequency, while the other one is used to control the duty cycle. The PWM waveform frequency and duty cycle can therefore be controlled by the values in the CCRA and CCRP registers.

An interrupt flag, one for each of the CCRA and CCRP, will be generated when a compare match occurs from either Comparator A or Comparator P. The PTnOC bit in the PTMnC1 register is used to select the required polarity of the PWM waveform while the two PTnIO1 and PTnIO0 bits are used to enable the PWM output or to force the PTMn output pin to a fixed high or low level. The PTnPOL bit is used to reverse the polarity of the PWM output waveform.

• 10-bit PTMn, PWM Output Mode, Edge-aligned Mode

CCRP	1~1023	0
Period	1~1023	1024
Duty	CCRA	

If $f_{SYS}=16\text{MHz}$, TM clock source select $f_{SYS}/4$, CCRP=512 and CCRA=128,

The PTMn PWM output frequency= $(f_{SYS}/4)/512=f_{SYS}/2048=8\text{kHz}$, duty= $128/512=25\%$,

If the Duty value defined by the CCRA register is equal to or greater than the Period value, then the PWM output duty is 100%.

Single Pulse Output Mode

To select this mode, bits PTnM1 and PTnM0 in the PTnMnC1 register should be set to 10 respectively and also the PTnIO1 and PTnIO0 bits should be set to 11 respectively. The Single Pulse Output Mode, as the name suggests, will generate a single shot pulse on the PTMn output pin.

The trigger for the pulse output leading edge is a low to high transition of the PTnON bit, which can be implemented using the application program. However in the Single Pulse Output Mode, the PTnON bit can also be made to automatically change from low to high using the external PTCKn pin, which will in turn initiate the Single Pulse output. When the PTnON bit transitions to a high level, the counter will start running and the pulse leading edge will be generated. The PTnON bit should remain high when the pulse is in its active state. The generated pulse trailing edge will be generated when the PTnON bit is cleared to zero, which can be implemented using the application program or when a compare match occurs from Comparator A.

However a compare match from Comparator A will also automatically clear the PTnON bit and thus generate the Single Pulse output trailing edge. In this way the CCRA value can be used to control the pulse width. A compare match from Comparator A will also generate a PTMn interrupt. The counter can only be reset back to zero when the PTnON bit changes from low to high when the counter restarts. In the Single Pulse Output Mode CCRP is not used. The PTnCCLR is not used in this Mode.

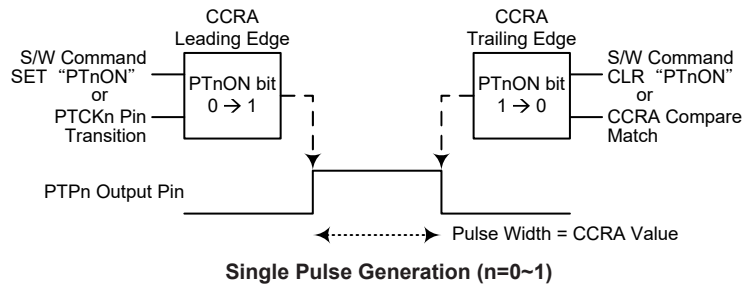

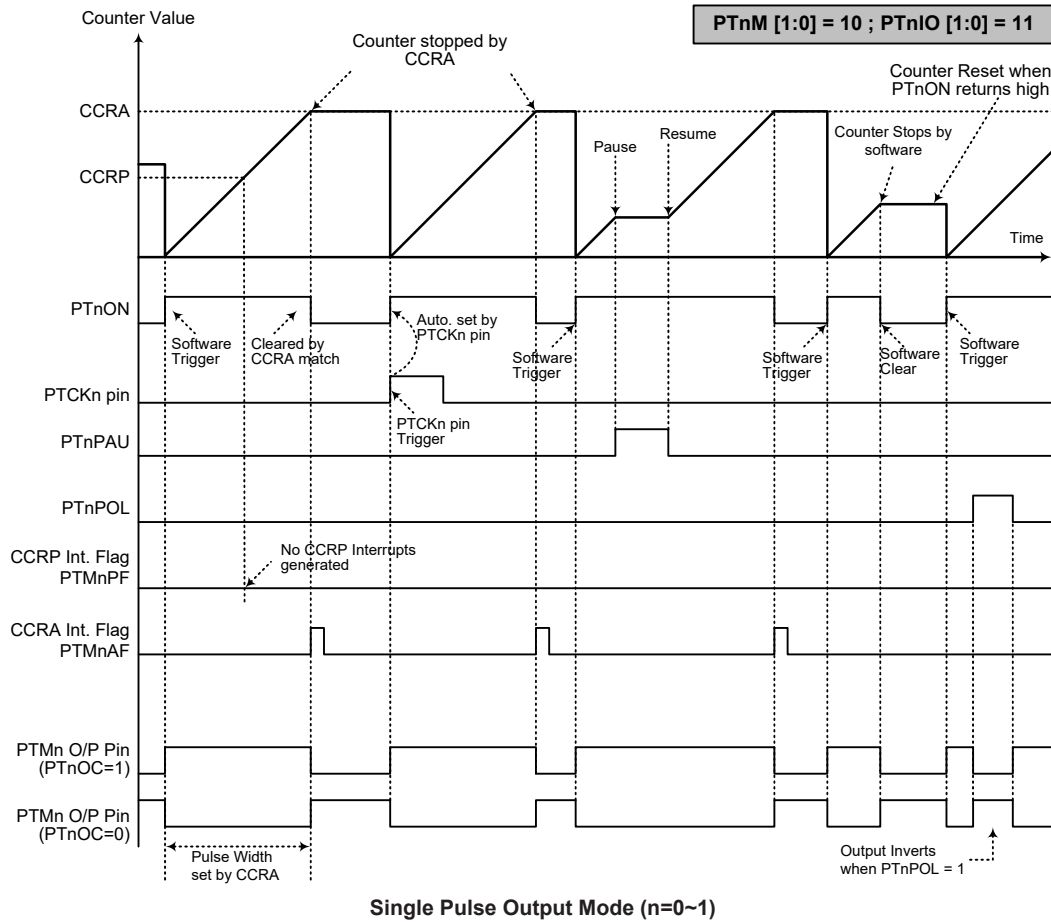

- Note:
1. Counter stopped by CCRA
 2. CCRP is not used
 3. The pulse triggered by the PTCKn pin or by setting the PTnON bit high
 4. A PTCKn pin active edge will automatically set the PTnON bit high
 5. In the Single Pulse Output Mode, PTnIO [1:0] must be set to "11" and cannot be changed

Capture Input Mode

To select this mode bits PTnM1 and PTnM0 in the PTMnC1 register should be set to 01 respectively. This mode enables external signals to capture and store the present value of the internal counter and can therefore be used for applications such as pulse width measurements. The external signal is supplied on the PTPnI or PTCKn pin, selected by the PTnCAPTS bit in the PTMnC1 register. The input pin active edge can be either a rising edge, a falling edge or both rising and falling edges; the active edge transition type is selected using the PTnIO1 and PTnIO0 bits in the PTMnC1 register. The counter is started when the PTnON bit changes from low to high which is initiated using the application program.

When the required edge transition appears on the PTPnI or PTCKn pin the present value in the counter will be latched into the CCRA registers and a PTMn interrupt generated. Irrespective of what events occur on the PTPnI or PTCKn pin the counter will continue to free run until the PTnON bit changes from high to low. When a CCRP compare match occurs the counter will reset back to zero; in this way the CCRP value can be used to control the maximum counter value. When a CCRP compare match occurs from Comparator P, a PTMn interrupt will also be generated. Counting the number of overflow interrupt signals from the CCRP can be a useful method in measuring long pulse widths. The PTnIO1 and PTnIO0 bits can select the active trigger edge on the PTPnI or PTCKn pin to be a rising edge, falling edge or both edge types. If the PTnIO1 and PTnIO0 bits are both set high, then no capture operation will take place irrespective of what happens on the PTPnI or PTCKn pin, however it must be noted that the counter will continue to run.

There are some considerations that should be noted. If PTCKn is used as the capture input source, then it cannot be selected as the PTMn clock source. If the captured pulse width is less than 2 timer clock periods, it may be ignored by hardware. After the counter value is latched to the CCRA registers by an active capture edge, the PTMnAF flag will be set high after 0.5 timer clock periods. The delay time from the active capture edge received to the action of latching counter value to CCRA registers is less than 1.5 timer clock periods.

The PTnCCLR, PTnOC and PTnPOL bits are not used in this Mode.

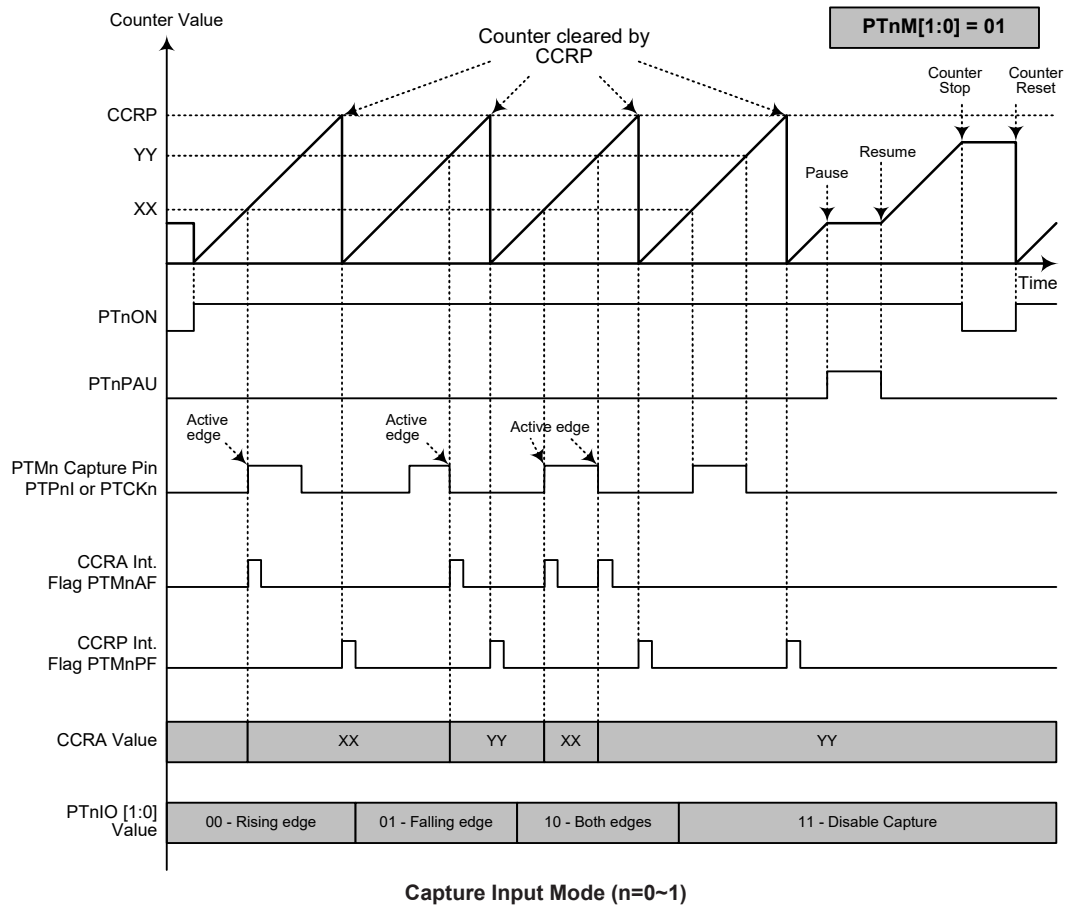

- Note: 1. PTnM[1:0]=01 and active edge set by the PTnIO[1:0] bits
 2. A PTMn Capture input pin active edge transfers the counter value to CCRA
 3. PTnCCLR bit not used
 4. No output function – PTnOC and PTnPOL bits are not used
 5. CCRP determines the counter value and the counter has a maximum count value when CCRP is equal to zero
 6. The capture input mode cannot be used if the selected PTMn counter clock is not available

Analog to Digital Converter

The need to interface to real world analog signals is a common requirement for many electronic systems. However, to properly process these signals by a microcontroller, they must first be converted into digital signals by A/D converters. By integrating the A/D conversion electronic circuitry into the microcontroller, the need for external components is reduced significantly with the corresponding follow-on benefits of lower costs and reduced component space requirements.

A/D Overview

These devices contain a multi-channel analog to digital converter which can directly interface to external analog signals, such as that from sensors or other control signals and convert these signals directly into a 12-bit digital value. It also can convert the internal signals, such as the internal reference voltage, into a 12-bit digital value. The external or internal analog signal to be converted is determined by the SAINS and SACS bit fields. When the external analog signal is to be converted, the corresponding external channel input pin function should first be properly configured and then the desired external channel input should be selected using the SAINS and SACS fields. Note that when the internal analog signal is selected to be converted, all external channel analog input pin function should first be deselected and then properly configured the SAINS and SACS fields. More detailed information about the A/D input signal selection will be described in the “A/D converter Control Registers” and “A/D Converter Input Signals” section respectively.

Device	External Input Channels	Internal Signal	A/D Signal Select
BS86C08C BS86D12C BS86E16C BS86D20C	AN0~AN7	V _{BG}	SAINS2~SAINS0 SACS3~SACS0

The accompanying block diagram shows the internal structure of the A/D converter together with its associated registers and control bits.

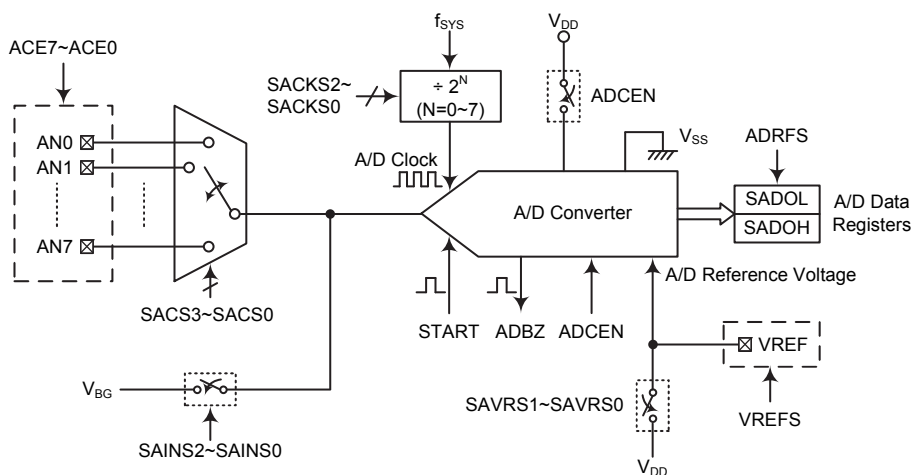

A/D Converter Structure

A/D Converter Register Description

Overall operation of the A/D converter is controlled using five registers. A read only register pair exists to store the A/D Converter data 12-bit value. The remaining three registers, SADC0, SADC1 and ACERL, are control registers which setup the operating conditions and control function of the A/D converter.

Register Name	Bit							
	7	6	5	4	3	2	1	0
SADOL (ADRFs=0)	D3	D2	D1	D0	—	—	—	—
SADOL (ADRFs=1)	D7	D6	D5	D4	D3	D2	D1	D0
SADOH (ADRFs=0)	D11	D10	D9	D8	D7	D6	D5	D4
SADOH (ADRFs=1)	—	—	—	—	D11	D10	D9	D8
SADC0	START	ADBZ	ADCEN	ADRFs	SACS3	SACS2	SACS1	SACS0
SADC1	SAINS2	SAINS1	SAINS0	SAVRS1	SAVRS0	SACKS2	SACKS1	SACKS0
ACERL	ACE7	ACE6	ACE5	ACE4	ACE3	ACE2	ACE1	ACE0

A/D Converter Register List

A/D Converter Data Registers – SADOL, SADOH

As these devices contain an internal 12-bit A/D converter, it requires two data registers to store the converted value. These are a high byte register, known as SADOH, and a low byte register, known as SADOL. After the conversion process takes place, these registers can be directly read by the microcontroller to obtain the digitised conversion value. As only 12 bits of the 16-bit register space is utilised, the format in which the data is stored is controlled by the ADRFS bit in the SADC0 register as shown in the accompanying table. D0~D11 are the A/D conversion result data bits. Any unused bits will be read as zero. The A/D data registers contents will be unchanged if the A/D converter is disabled.

ADRFs	SADOH								SADOL							
	7	6	5	4	3	2	1	0	7	6	5	4	3	2	1	0
0	D11	D10	D9	D8	D7	D6	D5	D4	D3	D2	D1	D0	0	0	0	0
1	0	0	0	0	D11	D10	D9	D8	D7	D6	D5	D4	D3	D2	D1	D0

A/D Converter Data Registers

A/D Converter Control Registers – SADC0, SADC1, ACERL

To control the function and operation of the A/D converter, three control registers known as SADC0, SADC1 and ACERL are provided. These 8-bit registers define functions such as the selection of which analog signal is connected to the internal A/D converter, the digitised data format, the A/D clock source as well as controlling the start function and monitoring the A/D converter busy status. As these devices contain only one actual analog to digital converter hardware circuit, each of the external and internal analog signals must be routed to the converter. The SACS3~SACS0 bits in the SADC0 register are used to determine which external channel input is selected to be converted. The SAINS2~SAINS0 bits in the SADC1 register are used to determine that the analog signal to be converted comes from the internal analog signal or external analog channel input.

The ACERL register contains the ACE7~ACE0 bits which determine which pins on I/O Ports are used as analog inputs for the A/D converter input and which pins are not. Setting the corresponding bit high will select the A/D input function while clearing the bit to zero will select either the I/O or other pin-shared function. When the pin is selected to be an A/D input, its original function whether it is an I/O or other pin-shared function will be removed. In addition, any internal pull-high resistor connected to the pin will be automatically removed if the pin is selected to be an A/D converter input.

• **SADC0 Register**

Bit	7	6	5	4	3	2	1	0
Name	START	ADBZ	ADCEN	ADRFS	SACS3	SACS2	SACS1	SACS0
R/W	R/W	R	R/W	R/W	R/W	R/W	R/W	R/W
POR	0	0	0	0	0	0	0	0

- Bit 7** **START:** Start the A/D Conversion
0→1→0: Start
This bit is used to initiate an A/D conversion process. The bit is normally low but if set high and then cleared low again, the A/D converter will initiate a conversion process.
- Bit 6** **ADBZ:** A/D Converter busy flag
0: No A/D conversion is in progress
1: A/D conversion is in progress
This read only flag is used to indicate whether the A/D conversion is in progress or not. When the START bit is set from low to high and then to low again, the ADBZ flag will be set to 1 to indicate that the A/D conversion is initiated. The ADBZ flag will be cleared to 0 after the A/D conversion is complete.
- Bit 5** **ADCEN:** A/D Converter function enable control
0: Disable
1: Enable
This bit controls the A/D internal function. This bit should be set to one to enable the A/D converter. If the bit is set low, then the A/D converter will be switched off reducing the device power consumption. When the A/D converter function is disabled, the contents of the A/D data register pair known as SADOH and SADOL will be unchanged.
- Bit 4** **ADRFS:** A/D conversion data format select
0: A/D converter data format → SADOH=D [11:4]; SADOL=D [3:0]
1: A/D converter data format → SADOH=D [11:8]; SADOL=D [7:0]
This bit controls the format of the 12-bit converted A/D value in the two A/D data registers. Details are provided in the A/D converter data register section.
- Bit 3~0** **SACS3~SACS0:** A/D converter external analog input channel select
0000: External AN0 input
0001: External AN1 input
0010: External AN2 input
0011: External AN3 input
0100: External AN4 input
0101: External AN5 input
0110: External AN6 input
0111: External AN7 input
1xxx: Non-existed channel, input floating if selected
These bits are used to select which external analog input channel is to be converted. When the external analog input channel is selected, the SAINS bit field must be set to “000”, “101” or “11x”. Details are summarized in the “A/D Converter Input Signal Selection” table.

• **SADC1 Register**

Bit	7	6	5	4	3	2	1	0
Name	SAINS2	SAINS1	SAINS0	SAVRS1	SAVRS0	SACKS2	SACKS1	SACKS0
R/W	R/W	R/W	R/W	R/W	R/W	R/W	R/W	R/W
POR	0	0	0	0	0	0	0	0

Bit 7~5 **SAINS2~SAINS0**: A/D converter input signal select
000: External source – External analog channel input, ANn
001: Internal source – Internal bandgap reference voltage, V_{BG}
010~100: Internal source – Reserved, connected to ground
101~111: External source – External analog channel input, ANn
Care must be taken if the SAINS field is set to “001” to select the internal analog signal to be converted. When the internal analog signal is selected to be converted, the external channel input pin must never be selected as the A/D input signal by properly setting the SACKS bit field with a value of “1xxx”. Otherwise, the external channel input will be connected together with the internal analog signal. This will result in unpredictable situations such as an irreversible damage.

Bit 4~3 **SAVRS1~SAVRS0**: A/D converter reference voltage select
00: External VREF pin
01: Internal A/D converter power, V_{DD}
1x: External VREF pin
These bits are used to select the A/D converter reference voltage source. Care must be taken if the SAVRS field is set to “01” to select the internal A/D converter power voltage as the reference voltage source. When the internal reference voltage source is selected, the external VREF cannot be configured as the reference voltage input by properly configuring the VREFS bit in the TMPC register. Otherwise, the external input voltage on the VREF pin will be connected to the internal A/D converter power. This will result in unpredictable situations.

Bit 2~0 **SACKS2~SACKS0**: A/D conversion clock source select
000: f_{sys}
001: f_{sys}/2
010: f_{sys}/4
011: f_{sys}/8
100: f_{sys}/16
101: f_{sys}/32
110: f_{sys}/64
111: f_{sys}/128
These bits are used to select the clock source for the A/D converter.

• **ACERL Register**

Bit	7	6	5	4	3	2	1	0
Name	ACE7	ACE6	ACE5	ACE4	ACE3	ACE2	ACE1	ACE0
R/W	R/W	R/W	R/W	R/W	R/W	R/W	R/W	R/W
POR	0	0	0	0	0	0	0	0

Bit 7 **ACE7**: AN7 input pin enable control
0: Disable – not A/D input
1: Enable – A/D input, AN7

Bit 6 **ACE6**: AN6 input pin enable control
0: Disable – not A/D input
1: Enable – A/D input, AN6

Bit 5 **ACE5**: AN5 input pin enable control
0: Disable – not A/D input
1: Enable – A/D input, AN5

Bit 4	ACE4: AN4 input pin enable control 0: Disable – not A/D input 1: Enable – A/D input, AN4 Note that for the BS86C08C/BS86D12C/BS86E16C device, as the AN4 pin is pin-shared with the VREF pin function, if the VREFS bit in the TMPC register is set high, the VREF pin will be selected and the AN4 pin function will be disabled automatically.
Bit 3	ACE3: AN3 input pin enable control 0: Disable – not A/D input 1: Enable – A/D input, AN3
Bit 2	ACE2: AN2 input pin enable control 0: Disable – not A/D input 1: Enable – A/D input, AN2
Bit 1	ACE1: AN1 input pin enable control 0: Disable – not A/D input 1: Enable – A/D input, AN1
Bit 0	ACE0: AN0 input pin enable control 0: Disable – not A/D input 1: Enable – A/D input, AN0 Note that for the BS86D20C device, as the AN0 pin is pin-shared with the VREF pin function, if the VREFS bit in the TMPC register is set high, the VREF pin will be selected and the AN0 pin function will be disabled automatically.

A/D Converter Reference Voltage

The actual reference voltage supply to the A/D Converter can be supplied from the positive power supply, V_{DD} , or an external reference source supplied on pin VREF determined by the SAVRS bit field in the SADC1 register. When the SAVRS field is set to “01”, the A/D converter reference voltage will come from the V_{DD} . Otherwise, the A/D converter reference voltage will come from the VREF pin if the SAVRS field is set to any other value except “01”. When the VREF pin is selected as the reference voltage supply pin, the VREFS bit in the TMPC register should first be properly configured to enable the VREF pin function as it is pin-shared with other functions. However, if the internal A/D converter power is selected as the reference voltage, the external VREF pin must not be configured as the reference voltage input function to avoid the internal connection between the VREF pin to the internal A/D converter power. Note that the analog input values must not be allowed to exceed the value of the selected reference voltage.

A/D Converter Input Signals

All of the external A/D analog input pins are pin-shared with the I/O pins as well as other functions. The corresponding pin-shared function control bits ACE_n in the ACERL register determine whether the external input pins are setup as A/D converter analog channel inputs or whether they have other functions. If the corresponding pin is setup to be an A/D converter analog channel input by setting the ACE_n bit high, the original pin function will be disabled. In this way, pins can be changed under program control to change their function between A/D inputs and other functions. All pull-high resistors, which are setup through register programming, will be automatically disconnected if the pins are setup as A/D inputs. Note that it is not necessary to first setup the A/D pin as an input in the port control register to enable the A/D input as when the relevant A/D input function selection bits enable an A/D input, the status of the port control register will be overridden.

As these devices contain only one actual analog to digital converter hardware circuit, one of the external or internal analog signals must be routed to the converter. The SAINS2~SAINS0 bits in the SADC1 register are used to determine that the analog signal to be converted comes from the external channel input or internal analog signal. The SACS3~SACS0 bits in the SADC0 register are

used to determine which external channel input is selected to be converted. If the SAINS2~SAINS0 bits are set to “000”, “101” or “11x”, the external channel input will be selected to be converted and the SACS3~SACS0 bits can determine which external channel is selected.

When the SAINS field is set to the value of “001”, the internal analog signal derived from the Bandgap reference voltage will be selected. If the internal analog signal is selected to be converted, the external channel signal input must be switched off by setting the SACS field to a value of “1xxx”. Otherwise, the internal analog signal will be connected together with the external channel input. This will result in unpredictable situations.

SAINS[2:0]	SACS[3:0]	Input Signals	Description
000, 101, 11x	0000~0111	AN0~AN7	External channel analog input ANn
	1xxx	—	Floating, no external channel is selected
001	1xxx	V _{BG}	Internal Bandgap reference voltage
010, 011, 100	1xxx	GND	Connected to the ground

A/D Converter Input Signal Selection

A/D Converter Operation

The START bit in the SADC0 register is used to start the AD conversion. When the microcontroller sets this bit from low to high and then low again, an analog to digital conversion cycle will be initiated.

The ADBZ bit in the SADC0 register is used to indicate whether the analog to digital conversion process is in progress or not. This bit will be automatically set to 1 by the microcontroller after an A/D conversion is successfully initiated. When the A/D conversion is complete, the ADBZ bit will be cleared to 0. In addition, the corresponding A/D interrupt request flag will be set in the interrupt control register, and if the A/D interrupt is enabled, an internal A/D interrupt signal will be generated. This A/D internal interrupt signal will direct the program flow to the associated A/D internal interrupt address for processing. If the A/D internal interrupt is disabled, the microcontroller can poll the ADBZ bit in the SADC0 register to check whether it has been cleared as an alternative method of detecting the end of an A/D conversion cycle.

The clock source for the A/D converter, which originates from the system clock f_{SYS} , can be chosen to be either f_{SYS} or a subdivided version of f_{SYS} . The division ratio value is determined by the SACKS bit field in the SADC1 register. Although the A/D clock source is determined by the system clock f_{SYS} and by bits SACKS2~SACKS0, there are some limitations on the A/D clock source speed that can be selected. As the recommended range of permissible A/D clock period, t_{ADCK} , is from 0.5 μ s to 10 μ s, care must be taken for system clock frequencies. For example, if the system clock operates at a frequency of 8MHz, the SACKS2~SACKS0 bits should not be set to 000, 001 or 111. Doing so will give A/D clock periods that are less than the minimum A/D clock period or greater than the maximum A/D clock period which may result in inaccurate A/D conversion values. Refer to the following table for examples, where values marked with an asterisk * show where, special care must be taken, as the values may be beyond the specified A/D Clock Period range.

f _{sys}	A/D Clock Period (t _{ADCK})							
	SACKS[2:0]=000 (f _{sys})	SACKS[2:0]=001 (f _{sys} /2)	SACKS[2:0]=010 (f _{sys} /4)	SACKS[2:0]=011 (f _{sys} /8)	SACKS[2:0]=100 (f _{sys} /16)	SACKS[2:0]=101 (f _{sys} /32)	SACKS[2:0]=110 (f _{sys} /64)	SACKS[2:0]=111 (f _{sys} /128)
1MHz	1μs	2μs	4μs	8μs	16μs*	32μs*	64μs*	128μs*
2MHz	500ns	1μs	2μs	4μs	8μs	16μs*	32μs*	64μs*
4MHz	250ns*	500ns	1μs	2μs	4μs	8μs	16μs*	32μs*
8MHz	125ns*	250ns*	500ns	1μs	2μs	4μs	8μs	16μs*
12MHz	83ns*	167ns*	333ns*	667ns	1.33μs	2.67μs	5.33μs	10.67μs*
16MHz	62.5ns*	125ns*	250ns*	500ns	1μs	2μs	4μs	8μs

A/D Clock Period Examples

Controlling the power on/off function of the A/D converter circuitry is implemented using the ADCEN bit in the SADC0 register. This bit must be set high to power on the A/D converter. When the ADCEN bit is set high to power on the A/D converter internal circuitry, a certain delay, as indicated in the timing diagram, must be allowed before an A/D conversion is initiated. Even if no pins are selected for use as A/D inputs by clearing the ACE7~ACE0 bits in the ACERL register, if the ADCEN bit is high, then some power will still be consumed. In power conscious applications it is therefore recommended that the ADCEN is set low to reduce power consumption when the A/D converter function is not being used.

Conversion Rate and Timing Diagram

A complete A/D conversion contains two parts, data sampling and data conversion. The data sampling which is defined as t_{ADS} takes 4 A/D clock periods and the data conversion takes 12 A/D clock periods. Therefore a total of 16 A/D clock periods for an analog signal A/D conversion which is defined as t_{ADC} are necessary.

$$\text{Maximum single A/D conversion rate} = 1/(\text{A/D clock period} \times 16)$$

The accompanying diagram shows graphically the various stages involved in an external channel input signal analog to digital conversion process and its associated timing. After an A/D conversion process has been initiated by the application program, the microcontroller internal hardware will begin to carry out the conversion, during which time the program can continue with other functions. The time taken for the A/D conversion is 16 t_{ADCK} where t_{ADCK} is equal to the A/D clock period.

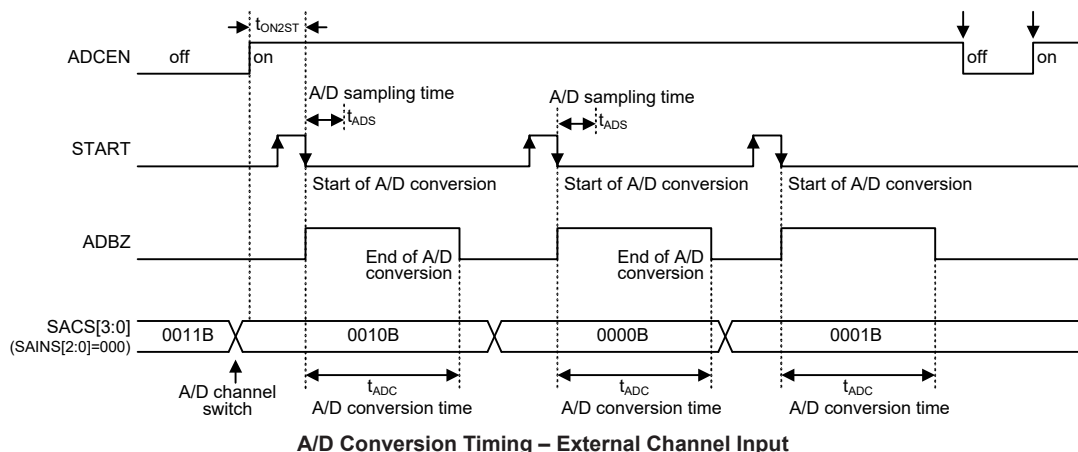

Summary of A/D Conversion Steps

The following summarises the individual steps that should be executed in order to implement an A/D conversion process.

- Step 1
Select the required A/D conversion clock by properly programming the SACKS2~SACKS0 bits in the SADC1 register.
- Step 2
Enable the A/D converter by setting the ADCEN bit in the SADC0 register to one.
- Step 3
Select which signal is to be connected to the internal A/D converter by correctly configuring the SACS and SAINS bit fields
Selecting the external channel input to be converted, go to Step 4.
Selecting the internal analog signal to be converted, go to Step 5.
- Step 4
If the SAINS field is 000, 101 or 11x, the external channel input can be selected. The desired external channel input is selected by configuring the SACS field. When the A/D input signal comes from the external channel input, the corresponding pin should be configured as an A/D input function by selecting the relevant function control bits, ACE_n. Then go to Step 6.
- Step 5
If the SAINS field is set to 001, the relevant internal analog signal can be selected. Before the A/D input signal is selected to come from the internal analog signal by properly configuring the SAINS field, the SACS field must be set to “1xxx” to select a non-existent channel input. Then go to Step 6.
- Step 6
Select the A/D converter output data format by configuring the ADRFS bit in the SADC0 register.
- Step 7
Select the A/D converter reference voltage source by configuring the SAVRS bit field in the SADC1 register. If the internal reference voltage is selected, the external reference input pin function must be disabled by properly configuring the VREFS bit in the TMPC register.
- Step 8
If A/D conversion interrupt is used, the interrupt control registers must be correctly configured to ensure the A/D interrupt function is active. The master interrupt control bit, EMI, and the A/D conversion interrupt control bit, ADE, must both be set high in advance.
- Step 9
The A/D conversion procedure can now be initialized by setting the START bit from low to high and then low again.
- Step 10
If A/D conversion is in progress, the ADBZ flag will be set high. After the A/D conversion process is complete, the ADBZ flag will go low and then the output data can be read from SADOH and SADOL registers.

Note: When checking for the end of the conversion process, if the method of polling the ADBZ bit in the SADC0 register is used, the interrupt enable step above can be omitted.

Programming Considerations

During microcontroller operations where the A/D converter is not being used, the A/D internal circuitry can be switched off to reduce power consumption, by clearing bit ADCEN to zero in the SADC0 register. When this happens, the internal A/D converter circuits will not consume power irrespective of what analog voltage is applied to their input lines. If the A/D converter input lines are used as normal I/Os, then care must be taken as if the input voltage is not at a valid logic level, then this may lead to some increase in power consumption.

A/D Transfer Function

As the devices contain a 12-bit A/D converter, its full-scale converted digitised value is equal to FFFH. Since the full-scale analog input value is equal to the actual A/D converter reference voltage, V_{REF} , this gives a single bit analog input value of reference voltage value divided by 4096.

$$1 \text{ LSB} = V_{REF} \div 4096$$

The A/D Converter input voltage value can be calculated using the following equation:

$$\text{A/D input voltage} = \text{A/D output digital value} \times (V_{REF} \div 4096)$$

The diagram shows the ideal transfer function between the analog input value and the digitised output value for the A/D converter. Except for the digitised zero value, the subsequent digitised values will change at a point 0.5 LSB below where they would change without the offset, and the last full scale digitised value will change at a point 1.5 LSB below the V_{REF} level. Note that here the V_{REF} voltage is the actual A/D converter reference voltage source determined by the SAVRS field.

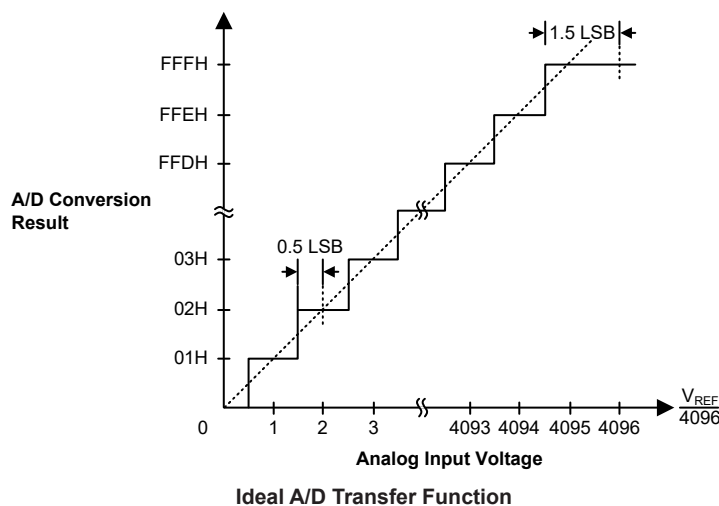

A/D Programming Examples

The following two programming examples illustrate how to setup and implement an A/D conversion. In the first example, the method of polling the ADBZ bit in the SADC0 register is used to detect when the conversion cycle is complete, whereas in the second example, the A/D interrupt is used to determine when the conversion is complete.

Example: using an ADBZ polling method to detect the end of conversion

```

clr ADE           ; disable ADC interrupt
mov a,03H        ; select fsys/8 as A/D clock and A/D input
mov SADC1,a      ; signal comes from external channel
                 ; select VREF pin voltage as A/D reference voltage source
mov a,01H
    
```

```

mov SADC0,a           ; and AN1 is selected as the external channel input
set ADCEN            ; enable the A/D converter
mov a,02H            ; setup ACERL to configure pin AN1 as analog input
mov ACERL,a
:
start_conversion:
clr START            ; high pulse on start bit to initiate conversion
set START            ; reset A/D
clr START            ; start A/D
:
polling_EOC:
sz ADBZ              ; poll the SADC0 register ADBZ bit to detect end of A/D conversion
jmp polling_EOC      ; continue polling
mov a,SADOL           ; read low byte conversion result value
mov SADOL_buffer,a  ; save result to user defined register
mov a,SAD0H           ; read high byte conversion result value
mov SAD0H_buffer,a  ; save result to user defined register
:
jmp start_conversion ; start next A/D conversion

```

Example: using the interrupt method to detect the end of conversion

```

clr ADE              ; disable ADC interrupt
mov a,03H            ; select fsys/8 as A/D clock and A/D input
mov SADC1,a          ; signal comes from external channel
                    ; select VREF pin voltage as A/D reference voltage source

mov a,01H
mov SADC0,a          ; and AN1 is selected as the external channel input
set ADCEN            ; enable the A/D converter
mov a,02H            ; setup ACERL to configure pin AN1 as analog input
mov ACERL,a
:
Start_conversion:
clr START            ; high pulse on START bit to initiate conversion
set START            ; reset A/D
clr START            ; start A/D
clr ADF              ; clear ADC interrupt request flag
set ADE              ; enable ADC interrupt
set EMI              ; enable global interrupt
:
:
ADC_ISR:             ; ADC interrupt service routine
mov acc_stack,a     ; save ACC to user defined memory
mov a,STATUS
mov status_stack,a ; save STATUS to user defined memory
:
mov a,SADOL           ; read low byte conversion result value
mov SADOL_buffer,a  ; save result to user defined register
mov a,SAD0H           ; read high byte conversion result value
mov SAD0H_buffer,a  ; save result to user defined register
:
EXIT_INT_ISR:
mov a,status_stack
mov STATUS,a        ; restore STATUS from user defined memory
mov a,acc_stack     ; restore ACC from user defined memory
reti

```

Touch Key Function

Each device provides multiple touch key functions. The touch key function is fully integrated and requires no external components, allowing touch key functions to be implemented by the simple manipulation of internal registers.

Touch Key Structure

The touch keys are pin-shared with the I/O pins, with the desired function chosen via the corresponding selection register bits. Keys are organised into several groups, with each group known as a module and having a module number, M0 to Mn. Each module is a fully independent set of four Touch Keys and each Touch Key has its own oscillator. Each module contains its own control logic circuits and register set. Examination of the register names will reveal the module number it is referring to.

Device	Total Key Number	Touch Key Module	Touch Key	
BS86C08C	8	Mn (n=0~1)	M0	KEY1~KEY4
			M1	KEY5~KEY8
BS86D12C	12	Mn (n=0~2)	M0	KEY1~KEY4
			M1	KEY5~KEY8
			M2	KEY9~KEY12
BS86E16C	16	Mn (n=0~3)	M0	KEY1~KEY4
			M1	KEY5~KEY8
			M2	KEY9~KEY12
			M3	KEY13~KEY16
BS86D20C	20	Mn (n=0~4)	M0	KEY1~KEY4
			M1	KEY5~KEY8
			M2	KEY9~KEY12
			M3	KEY13~KEY16
			M4	KEY17~KEY20

Touch Key Structure

Touch Key Register Definition

Each touch key module, which contains four touch key functions, has its own suite registers. The following table shows the register set for each touch key module. The Mn within the register name refers to the Touch Key module number. The series of devices has up to five Touch Key Modules dependent upon the selected device.

Register Name	Description
TKTMR	Touch key time slot 8-bit counter preload register
TKC0	Touch key function Control register 0
TKC1	Touch key function Control register 1
TK16DL	Touch key function 16-bit counter low byte
TK16DH	Touch key function 16-bit counter high byte
TKMn16DL	Touch key module n 16-bit C/F counter low byte
TKMn16DH	Touch key module n 16-bit C/F counter high byte
TKMnROL	Touch key module n reference oscillator capacitor select low byte
TKMnROH	Touch key module n reference oscillator capacitor select high byte
TKMnC0	Touch key module n Control register 0
TKMnC1	Touch key module n Control register 1

Touch Key Function Register Definition (n=0~4)

Register Name	Bit							
	7	6	5	4	3	2	1	0
TKTMR	D7	D6	D5	D4	D3	D2	D1	D0
TKC0	—	TKRCOV	TKST	TKCFOV	TK16OV	TSCS	TK16S1	TK16S0
TKC1	—	—	—	—	—	—	TKFS1	TKFS0
TK16DL	D7	D6	D5	D4	D3	D2	D1	D0
TK16DH	D15	D14	D13	D12	D11	D10	D9	D8
TKMn16DL	D7	D6	D5	D4	D3	D2	D1	D0
TKMn16DH	D15	D14	D13	D12	D11	D10	D9	D8
TKMnROL	D7	D6	D5	D4	D3	D2	D1	D0
TKMnROH	—	—	—	—	—	—	D9	D8
TKMnC0	MnMXS1	MnMXS0	MnDFEN	MnFILEN	MnSOFC	MnSOF2	MnSOF1	MnSOF0
TKMnC1	MnTSS	—	MnROEN	MnKOEN	MnK4IO	MnK3IO	MnK2IO	MnK1IO

Touch Key Function Register List (n=0~4)

• **TKTMR Register**

Bit	7	6	5	4	3	2	1	0
Name	D7	D6	D5	D4	D3	D2	D1	D0
R/W	R/W	R/W	R/W	R/W	R/W	R/W	R/W	R/W
POR	0	0	0	0	0	0	0	0

Bit 7~0 **D7~D0:** Touch key time slot 8-bit counter preload register

The touch key time slot counter preload register is used to determine the touch key time slot overflow time. The time slot unit period is obtained by a 5-bit counter and equal to 32 time slot clock cycles. Therefore, the time slot counter overflow time is equal to the following equation shown.

Time slot counter overflow time=(256–TKTMR[7:0])×32 t_{TSC} , where t_{TSC} is the time slot counter clock period.

• **TKC0 Register**

Bit	7	6	5	4	3	2	1	0
Name	—	TKRCOV	TKST	TKCFOV	TK16OV	TSCS	TK16S1	TK16S0
R/W	—	R/W	R/W	R/W	R/W	R/W	R/W	R
POR	—	0	0	0	0	0	0	0

Bit 7 Unimplemented, read as “0”

Bit 6 **TKRCOV:** Touch key time slot counter overflow flag

- 0: No overflow occurs
- 1: Overflow occurs

This bit can be accessed by application program. When this bit is set by touch key time slot counter overflow, the corresponding touch key interrupt request flag will be set. However, if this bit is set by application program, the touch key interrupt request flag will not be affected. Therefore, this bit cannot be set by application program but must be cleared to 0 by application program.

If the module 0 or all module time slot counter, selected by the TSCS bit, overflows, the TKRCOV bit and the Touch Key Interrupt request flag, TKMF, will be set and all module key oscillators and reference oscillators will automatically stop. The touch key module 16-bit C/F counter, touch key function 16-bit counter, 5-bit time slot unit period counter and 8-bit time slot counter will be automatically switched off.

- Bit 5 **TKST**: Touch key detection Start control
 0: Stopped or no operation
 0 → 1: Start detection
 In all modules the touch key module 16-bit C/F counter, touch key function 16-bit counter and 5-bit time slot unit period counter will automatically be cleared when this bit is cleared to zero. However, the 8-bit programmable time slot counter will not be cleared. When this bit is changed from low to high, the touch key module 16-bit C/F counter, touch key function 16-bit counter, 5-bit time slot unit period counter and 8-bit time slot counter will be switched on together with the key and reference oscillators to drive the corresponding counters.
- Bit 4 **TKCFOV**: Touch key module 16-bit C/F counter overflow flag
 0: No overflow occurs
 1: Overflow occurs
 This bit is set high by the touch key module 16-bit C/F counter overflow and must be cleared to 0 by application programs.
- Bit 3 **TK16OV**: Touch key function 16-bit counter overflow flag
 0: No overflow occurs
 1: Overflow occurs
 This bit is set high by the touch key function 16-bit counter overflow and must be cleared to 0 by application programs.
- Bit 2 **TSCS**: Touch key time slot counter select
 0: Each touch key module uses its own time slot counter
 1: All touch key modules use Module 0 time slot counter
- Bit 1~0 **TK16S1~TK16S0**: Touch key function 16-bit counter clock source select
 00: f_{SYS}
 01: $f_{SYS}/2$
 10: $f_{SYS}/4$
 11: $f_{SYS}/8$

• **TKC1 Register**

Bit	7	6	5	4	3	2	1	0
Name	—	—	—	—	—	—	TKFS1	TKFS0
R/W	—	—	—	—	—	—	R/W	R/W
POR	—	—	—	—	—	—	1	1

- Bit 7~2 Unimplemented, read as “0”
- Bit 1~0 **TKFS1~TKFS0**: Touch Key oscillator and Reference oscillator frequency select
 00: 1MHz
 01: 3MHz
 10: 7MHz
 11: 11MHz

• **TK16DH/TK16DL – Touch Key Function 16-bit Counter Register Pair**

Register	TK16DH								TK16DL							
	7	6	5	4	3	2	1	0	7	6	5	4	3	2	1	0
Name	D15	D14	D13	D12	D11	D10	D9	D8	D7	D6	D5	D4	D3	D2	D1	D0
R/W	R	R	R	R	R	R	R	R	R	R	R	R	R	R	R	R
POR	0	0	0	0	0	0	0	0	0	0	0	0	0	0	0	0

This register pair is used to store the touch key function 16-bit counter value. This 16-bit counter can be used to calibrate the reference or key oscillator frequency. When the touch key time slot counter overflows, this 16-bit counter will be stopped and the counter content will be unchanged. This register pair will be cleared to zero when the TKST bit is set low.

• **TKMn16DH/TKMn16DL – Touch Key Module n 16-bit C/F Counter Register Pair**

Register	TKMn16DH								TKMn16DL							
Bit	7	6	5	4	3	2	1	0	7	6	5	4	3	2	1	0
Name	D15	D14	D13	D12	D11	D10	D9	D8	D7	D6	D5	D4	D3	D2	D1	D0
R/W	R	R	R	R	R	R	R	R	R	R	R	R	R	R	R	R
POR	0	0	0	0	0	0	0	0	0	0	0	0	0	0	0	0

This register pair is used to store the touch key module n 16-bit C/F counter value. This 16-bit C/F counter will be stopped and the counter content will be kept unchanged when the touch key time slot counter overflows. This register pair will be cleared to zero when the TKST bit is set low.

• **TKMnROH/TKMnROL – Touch Key Module n Reference Oscillator Capacitor Select Register Pair**

Register	TKMnROH								TKMnROL							
Bit	7	6	5	4	3	2	1	0	7	6	5	4	3	2	1	0
Name	—	—	—	—	—	—	D9	D8	D7	D6	D5	D4	D3	D2	D1	D0
R/W	—	—	—	—	—	—	R/W	R/W	R/W	R/W	R/W	R/W	R/W	R/W	R/W	R/W
POR	—	—	—	—	—	—	0	0	0	0	0	0	0	0	0	0

This register pair is used to store the touch key module n reference oscillator capacitor value. The reference oscillator internal capacitor value=(TKMnRO[9:0]×50pF)/1024.

• **TKMnC0 Register**

Bit	7	6	5	4	3	2	1	0
Name	MnMXS1	MnMXS0	MnDFEN	MnFILEN	MnSOFC	MnSOF2	MnSOF1	MnSOF0
R/W	R/W	R/W	R/W	R/W	R/W	R/W	R/W	R/W
POR	0	0	0	0	0	0	0	0

Bit 7~6 **MnMXS1~MnMXS0**: Multiplexer Key Select

Bit	Touch Key Module Number				
MnMXS[1:0]	M0	M1	M2	M3	M4
00	KEY1	KEY5	KEY9	KEY13	KEY17
01	KEY2	KEY6	KEY10	KEY14	KEY18
10	KEY3	KEY7	KEY11	KEY15	KEY19
11	KEY4	KEY8	KEY12	KEY16	KEY20
BS86C08C	√	√	—	—	—
BS86D12C	√	√	√	—	—
BS86E16C	√	√	√	√	—
BS86D20C	√	√	√	√	√

Bit 5 **MnDFEN**: Touch key module n multi-frequency control

- 0: Disable
- 1: Enable

This bit is used to control the touch key oscillator frequency doubling function. When this bit is set to 1, the key oscillator frequency will be doubled.

Bit 4 **MnFILEN**: Touch key module n filter function control

- 0: Disable
- 1: Enable

Bit 3 **MnSOFC**: Touch key module n C-to-F oscillator frequency hopping function control select

- 0: Controlled by the MnSOF2~MnSOF0
- 1: Controlled by hardware circuit

This bit is used to select the touch key oscillator frequency hopping function control method. When this bit is set to 1, the key oscillator frequency hopping function is controlled by the hardware circuit regardless of the MnSOF2~MnSOF0 bits value.

- Bit 2~0 **MnSOF2~MnSOF0**: Touch key module n Reference and Key oscillators hopping frequency select (MnSOFC=0)
- 000: 1.020MHz
 - 001: 1.040MHz
 - 010: 1.059MHz
 - 011: 1.074MHz
 - 100: 1.085MHz
 - 101: 1.099MHz
 - 110: 1.111MHz
 - 111: 1.125MHz

These bits are used to select the touch key oscillator frequency for the hopping function. Note that these bits are only available when the MnSOFC bit is cleared to 0.

The frequency mentioned here will be changed when the external or internal capacitor is with different values. If the touch key operates at 1MHz frequency, users can adjust the frequency in scale when any other frequency is selected.

• **TKMnC1 Register**

Bit	7	6	5	4	3	2	1	0
Name	MnTSS	—	MnROEN	MnKOEN	MnK4IO	MnK3IO	MnK2IO	MnK1IO
R/W	R/W	—	R/W	R/W	R/W	R/W	R/W	R/W
POR	0	—	0	0	0	0	0	0

- Bit 7 **MnTSS**: Touch key module n time slot counter clock source select
 0: Touch key module n reference oscillator
 1: $f_{SYS}/4$

- Bit 6 Unimplemented, read as “0”

- Bit 5 **MnROEN**: Touch key module n Reference oscillator enable control
 0: Disable
 1: Enable

- Bit 4 **MnKOEN**: Touch key module n Key oscillator enable control
 0: Disable
 1: Enable

- Bit 3 **MnK4IO**: Touch key module n Key 4 enable control

MnK4IO	Touch Key Module n (Mn)				
	M0	M1	M2	M3	M4
0: Disable	I/O or other functions				
1: Enable	KEY4	KEY8	KEY12	KEY16	KEY20
BS86C08C	√	√	—	—	—
BS86D12C	√	√	√	—	—
BS86E16C	√	√	√	√	—
BS86D20C	√	√	√	√	√

- Bit 2 **MnK3IO**: Touch key module n Key 3 enable control

MnK3IO	Touch Key Module n (Mn)				
	M0	M1	M2	M3	M4
0: Disable	I/O or other functions				
1: Enable	KEY3	KEY7	KEY11	KEY15	KEY19
BS86C08C	√	√	—	—	—
BS86D12C	√	√	√	—	—
BS86E16C	√	√	√	√	—
BS86D20C	√	√	√	√	√

Bit 1 **MnK2IO**: Touch key module n Key 2 enable control

MnK2IO	Touch Key Module n (Mn)				
	M0	M1	M2	M3	M4
0: Disable	I/O or other functions				
1: Enable	KEY2	KEY6	KEY10	KEY14	KEY18
BS86C08C	√	√	—	—	—
BS86D12C	√	√	√	—	—
BS86E16C	√	√	√	√	—
BS86D20C	√	√	√	√	√

Bit 0 **MnK1IO**: Touch key module n Key 1 enable control

MnK1IO	Touch Key Module n (Mn)				
	M0	M1	M2	M3	M4
0: Disable	I/O or other functions				
1: Enable	KEY1	KEY5	KEY9	KEY13	KEY17
BS86C08C	√	√	—	—	—
BS86D12C	√	√	√	—	—
BS86E16C	√	√	√	√	—
BS86D20C	√	√	√	√	√

Touch Key Operation

When a finger touches or is in proximity to a touch pad, the capacitance of the pad will increase. By using this capacitance variation to change slightly the frequency of the internal sense oscillator, touch actions can be sensed by measuring these frequency changes. Using an internal programmable divider the reference clock is used to generate a fixed time period. By counting a number of generated clock cycles from the sense oscillator during this fixed time period touch key actions can be determined.

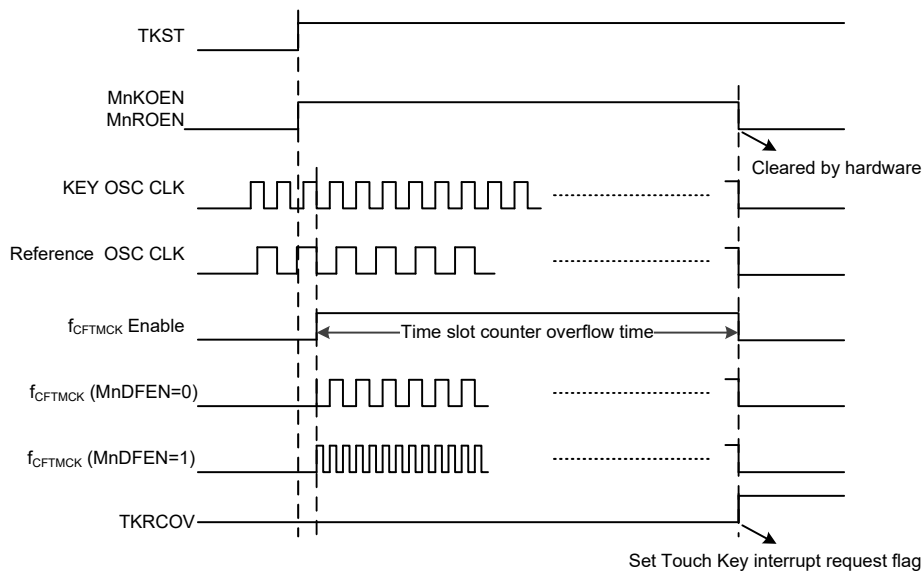

Touch Key Scan Mode Timing Diagram

Each touch key module contains four touch key inputs which are shared with logical I/O pins, and the desired function is selected using register bits. Each touch key has its own independent sense oscillator. Therefore, there are four sense oscillators within each touch key module.

During this reference clock fixed interval, the number of clock cycles generated by the sense oscillator is measured, and it is this value that is used to determine if a touch action has been made or not. At the end of the fixed reference clock time interval a Touch Key interrupt signal will be generated.

Using the TSCS bit in the TKC0 register can select the module 0 time slot counter as the time slot counter for all modules. All modules use the same started signal, TKST, in the TKC0 register. The touch key module 16-bit C/F counter, touch key function 16-bit counter, 5-bit time slot unit period counter in all modules will be automatically cleared when the TKST bit is cleared to zero, but the 8-bit programmable time slot counter will not be cleared. The overflow time is setup by user. When the TKST bit changes from low to high, the 16-bit C/F counter, touch key function 16-bit counter, 5-bit time slot unit period counter and 8-bit time slot timer counter will be automatically switched on.

The key oscillator and reference oscillator in all modules will be automatically stopped and the 16-bit C/F counter, touch key function 16-bit counter, 5-bit time slot unit period counter and 8-bit time slot timer counter will be automatically switched off when the time slot counter overflows. The clock source for the time slot counter is sourced from the reference oscillator or $f_{SYS}/4$ which is selected using the MnTSS bit in the TKMnC1 register. The reference oscillator and key oscillator will be enabled by setting the MnROEN bit and MnKOEN bits in the TKMnC1 register.

When the time slot counter in all the touch key modules or in the touch key module 0 overflows, an actual touch key interrupt will take place. The touch keys mentioned here are the keys which are enabled.

Each touch key module consists of four touch keys, KEY1~KEY4 are contained in module 0, KEY5~KEY8 are contained in module 1, KEY9~KEY12 are contained in module 2, etc. Each touch key module has an identical structure.

Touch Key Interrupt

The touch key only has single interrupt, when the time slot counter in all the touch key modules or in the touch key module 0 overflows, an actual touch key interrupt will take place. The touch keys mentioned here are the keys which are enabled. The 16-bit C/F counter, 16-bit counter, 5-bit time slot unit period counter and 8-bit time slot counter in all modules will be automatically cleared. More details regarding the touch key interrupt is located in the interrupt section of the datasheet.

Programming Considerations

After the relevant registers are setup, the touch key detection process is initiated by changing the TKST bit from low to high. This will enable and synchronise all relevant oscillators. The TKRCOV flag which is the time slot counter flag will go high when the counter overflows. When this happens an interrupt signal will be generated. As the TKRCOV flag will not be automatically cleared, it has to be cleared by the application program.

The TKCFOV flag which is the 16-bit C/F counter overflow flag will go high when any of the Touch Key Module 16-bit C/F counter overflows. As this flag will not be automatically cleared, it has to be cleared by the application program.

The TK16OV flag which is the 16-bit counter overflow flag will go high when the 16-bit counter overflows. As this flag will not be automatically cleared, it has to be cleared by the application program.

When the external touch key size and layout are defined, their related capacitances will then determine the sensor oscillator frequency.

I²C Interface – BS86C08C/BS86D12C/BS86E16C

The I²C interface is used to communicate with external peripheral devices such as sensors, EEPROM memory etc. Originally developed by Philips, it is a two line low speed serial interface for synchronous serial data transfer. The advantage of only two lines for communication, relatively simple communication protocol and the ability to accommodate multiple devices on the same bus has made it an extremely popular interface type for many applications.

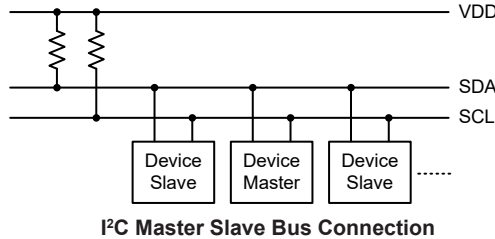

I²C Interface Operation

The I²C serial interface is a two line interface, a serial data line, SDA, and serial clock line, SCL. As many devices may be connected together on the same bus, their outputs are both open drain types. For this reason it is necessary that external pull-high resistors are connected to these outputs. Note that no chip select line exists, as each device on the I²C bus is identified by a unique address which will be transmitted and received on the I²C bus.

When two devices communicate with each other on the bidirectional I²C bus, one is known as the master device and one as the slave device. Both master and slave can transmit and receive data. However, it is the master device that has overall control of the bus. For these devices, which only operate in slave mode, there are two methods of transferring data on the I²C bus, the slave transmit mode and the slave receive mode. It is suggested that the device shall not enter the IDLE or SLEEP mode during the I²C communication is in progress. The pull-high control function pin-shared with SCL/SDA pin is still applicable even if I²C device is activated and the related internal pull-high function could be controlled by its corresponding pull-high control register.

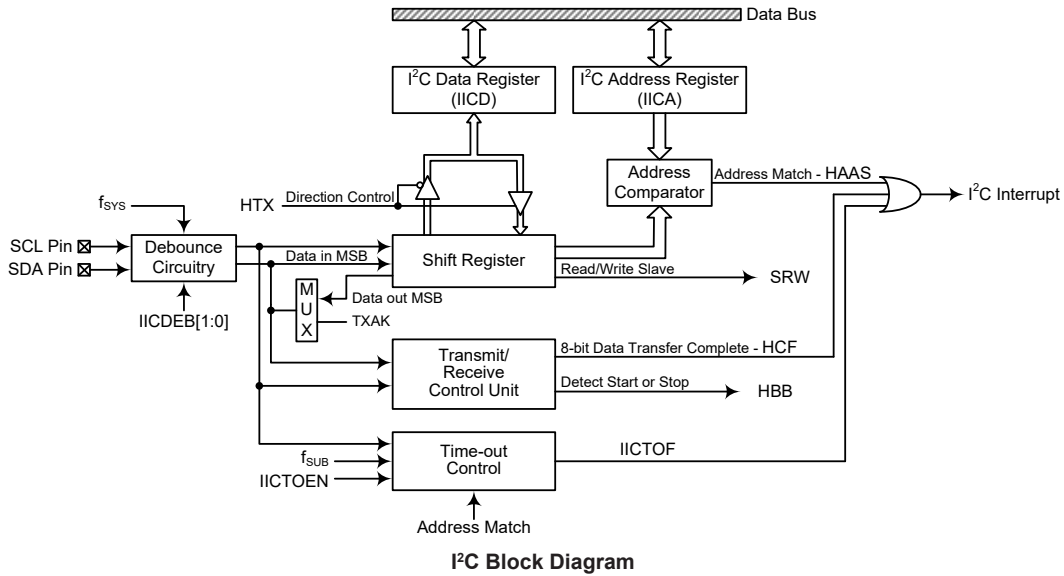

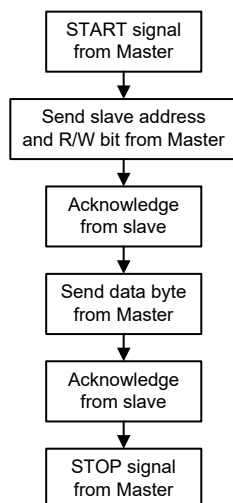

I²C Interface Operation

The IICDEB1 and IICDEB0 bits determine the debounce time of the I²C interface. This uses the internal clock to in effect add a debounce time to the external clock to reduce the possibility of glitches on the clock line causing erroneous operation. The debounce time, if selected, can be chosen to be either 2 or 4 system clocks. To achieve the required I²C data transfer speed, there exists a relationship between the system clock, f_{SYS} , and the I²C debounce time. For either the I²C Standard or Fast mode operation, users must take care of the selected system clock frequency and the configured debounce time to match the criterion shown in the following table.

I ² C Debounce Time Selection	I ² C Standard Mode (100kHz)	I ² C Fast Mode (400kHz)
No Debounce	$f_{SYS} > 2\text{MHz}$	$f_{SYS} > 5\text{MHz}$
2 system clock debounce	$f_{SYS} > 4\text{MHz}$	$f_{SYS} > 10\text{MHz}$
4 system clock debounce	$f_{SYS} > 8\text{MHz}$	$f_{SYS} > 20\text{MHz}$

I²C Minimum f_{SYS} Frequency Requirements

I²C Registers

There are three control registers associated with the I²C bus, IICC0, IICC1 and IICTOC, one address register IICA and one data register, IICD.

Register Name	Bit							
	7	6	5	4	3	2	1	0
IICC0	—	—	—	—	IICDEB1	IICDEB0	IICEN	—
IICC1	HCF	HAAS	HBB	HTX	TXAK	SRW	IAMWU	RXAK
IICD	D7	D6	D5	D4	D3	D2	D1	D0
IICA	IICA6	IICA5	IICA4	IICA3	IICA2	IICA1	IICA0	—
IICTOC	IICTOEN	IICTOF	IICTOS5	IICTOS4	IICTOS3	IICTOS2	IICTOS1	IICTOS0

I²C Register List

I²C Data Register

The IICD register is used to store the data being transmitted and received. Before the device writes data to the I²C bus, the actual data to be transmitted must be placed in the IICD register. After the data is received from the I²C bus, the device can read it from the IICD register. Any transmission or reception of data from the I²C bus must be made via the IICD register.

• **IICD Register**

Bit	7	6	5	4	3	2	1	0
Name	D7	D6	D5	D4	D3	D2	D1	D0
R/W	R/W	R/W	R/W	R/W	R/W	R/W	R/W	R/W
POR	x	x	x	x	x	x	x	x

“x”: unknown

Bit 7~0 **D7~D0**: I²C data register bit 7 ~ bit 0

I²C Address Register

The IICA register is the location where the 7-bit slave address of the slave device is stored. Bits 7~1 of the IICA register define the device slave address. Bit 0 is not defined. When a master device, which is connected to the I²C bus, sends out an address, which matches the slave address in the IICA register, the slave device will be selected.

• **IICA Register**

Bit	7	6	5	4	3	2	1	0
Name	IICA6	IICA5	IICA4	IICA3	IICA2	IICA1	IICA0	—
R/W	R/W	R/W	R/W	R/W	R/W	R/W	R/W	—
POR	0	0	0	0	0	0	0	—

Bit 7~1 **IICA6~IICA0**: I²C slave address
IICA6~IICA0 is the I²C slave address bit 6 ~ bit 0.

Bit 0 Unimplemented, read as “0”

I²C Control Registers

There are three control registers for the I²C interface, IICC0, IICC1 and IICTOC. The IICC0 register is used to control the enable/disable function and to set the data transmission clock frequency. The IICC1 register contains the relevant flags which are used to indicate the I²C communication status. Another register, IICTOC, is used to control the I²C time-out function and is described in the corresponding section.

• **IICC0 Register**

Bit	7	6	5	4	3	2	1	0
Name	—	—	—	—	IICDEB1	IICDEB0	IICEN	—
R/W	—	—	—	—	R/W	R/W	R/W	—
POR	—	—	—	—	0	0	0	—

Bit 7~4 Unimplemented, read as “0”

Bit 3~2 **IICDEB1~IICDEB0**: I²C Debounce Time Selection

- 00: No debounce
- 01: 2 system clock debounce
- 1x: 4 system clock debounce

Note that the I²C debounce circuit will operate normally if the system clock, f_{SYS} , is derived from the f_{H} clock or the IAMWU bit is equal to 0. Otherwise, the debounce circuit will have no effect and be bypassed.

Bit 1 **IICEN**: I²C Enable Control

- 0: Disable
- 1: Enable

The bit is the overall on/off control for the I²C interface. When the IICEN bit is cleared to zero to disable the I²C interface, the SDA and SCL lines will lose their I²C function and the I²C operating current will be reduced to a minimum value. When the bit is high the I²C interface is enabled. The I²C configuration option must have first enabled the I²C interface for this bit to be effective. If the IICEN bit changes from low to high,

the contents of the I²C control bits such as HTX and TXAK will remain at the previous settings and should therefore be first initialised by the application program while the relevant I²C flags such as HCF, HAAS, HBB, SRW and RXAK will be set to their default states.

Bit 0 Unimplemented, read as “0”

• **IICC1 Register**

Bit	7	6	5	4	3	2	1	0
Name	HCF	HAAS	HBB	HTX	TXAK	SRW	IAMWU	RXAK
R/W	R	R	R	R/W	R/W	R	R/W	R
POR	1	0	0	0	0	0	0	1

- Bit 7 HCF:** I²C Bus data transfer completion flag
 0: Data is being transferred
 1: Completion of an 8-bit data transfer
 The HCF flag is the data transfer flag. This flag will be zero when data is being transferred. Upon completion of an 8-bit data transfer the flag will go high and an interrupt will be generated.
- Bit 6 HAAS:** I²C Bus address match flag
 0: Not address match
 1: Address match
 The HAAS flag is the address match flag. This flag is used to determine if the slave device address is the same as the master transmit address. If the addresses match then this bit will be high, if there is no match then the flag will be low.
- Bit 5 HBB:** I²C Bus busy flag
 0: I²C Bus is not busy
 1: I²C Bus is busy
 The HBB flag is the I²C busy flag. This flag will be “1” when the I²C bus is busy which will occur when a START signal is detected. The flag will be set to “0” when the bus is free which will occur when a STOP signal is detected.
- Bit 4 HTX:** I²C slave device is transmitter or receiver selection
 0: Slave device is the receiver
 1: Slave device is the transmitter
- Bit 3 TXAK:** I²C Bus transmit acknowledge flag
 0: Slave send acknowledge flag
 1: Slave do not send acknowledge flag
 The TXAK bit is the transmit acknowledge flag. After the slave device receipt of 8 bits of data, this bit will be transmitted to the bus on the 9th clock from the slave device. The slave device must always set TXAK bit to “0” before further data is received.
- Bit 2 SRW:** I²C Slave Read/Write flag
 0: Slave device should be in receive mode
 1: Slave device should be in transmit mode
 The SRW flag is the I²C Slave Read/Write flag. This flag determines whether the master device wishes to transmit or receive data from the I²C bus. When the transmitted address and slave address is match, that is when the HAAS flag is set high, the slave device will check the SRW flag to determine whether it should be in transmit mode or receive mode. If the SRW flag is high, the master is requesting to read data from the bus, so the slave device should be in transmit mode. When the SRW flag is zero, the master will write data to the bus, therefore the slave device should be in receive mode to read this data.
- Bit 1 IAMWU:** I²C Address Match Wake-up control
 0: Disable
 1: Enable
 This bit should be set to 1 to enable the I²C address match wake up from the SLEEP or IDLE Mode. If the IAMWU bit has been set before entering either the SLEEP or IDLE mode to enable the I²C address match wake up, then this bit must be cleared by the application program after wake-up to ensure correction device operation.

Bit 0 **RXAK:** I²C Bus Receive acknowledge flag
 0: Slave receive acknowledge flag
 1: Slave does not receive acknowledge flag

The RXAK flag is the receiver acknowledge flag. When the RXAK flag is “0”, it means that a acknowledge signal has been received at the 9th clock, after 8 bits of data have been transmitted. When the slave device in the transmit mode, the slave device checks the RXAK flag to determine if the master receiver wishes to receive the next byte. The slave transmitter will therefore continue sending out data until the RXAK flag is “1”. When this occurs, the slave transmitter will release the SDA line to allow the master to send a STOP signal to release the I²C Bus.

I²C Bus Communication

Communication on the I²C bus requires four separate steps, a START signal, a slave device address transmission, a data transmission and finally a STOP signal. When a START signal is placed on the I²C bus, all devices on the bus will receive this signal and be notified of the imminent arrival of data on the bus. The first seven bits of the data will be the slave address with the first bit being the MSB. If the address of the slave device matches that of the transmitted address, the HAAS bit in the IICC1 register will be set and an I²C interrupt will be generated. After entering the interrupt service routine, the slave device must first check the condition of the HAAS and IICTOF bits to determine whether the interrupt source originates from an address match or from the completion of an 8-bit data transfer completion or from the I²C bus time-out occurrence. During a data transfer, note that after the 7-bit slave address has been transmitted, the following bit, which is the 8th bit, is the read/write bit whose value will be placed in the SRW bit. This bit will be checked by the slave device to determine whether to go into transmit or receive mode. Before any transfer of data to or from the I²C bus, the microcontroller must initialise the bus, the following are steps to achieve this:

- Step 1
Set the IICEN bit in the IICC0 register to “1” to enable the I²C bus.
- Step 2
Write the slave address of the device to the I²C bus address register IICA.
- Step 3
Set the IICE interrupt enable bit of the interrupt control register to enable the I²C interrupt.

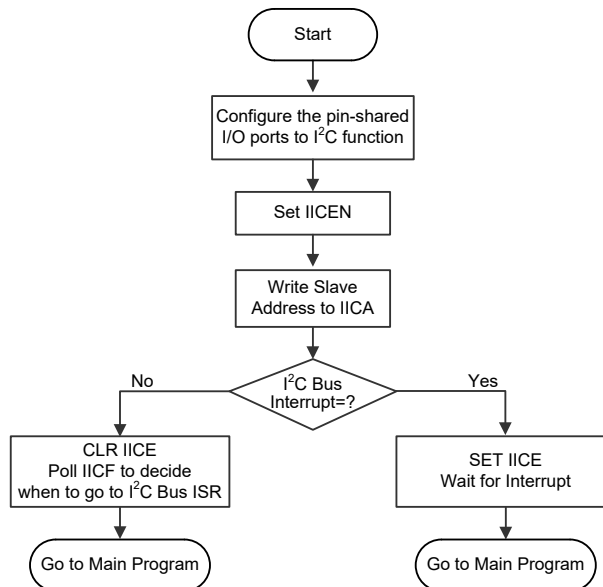

I²C Bus Initialisation Flowchart

I²C Bus Start Signal

The START signal can only be generated by the master device connected to the I²C bus and not by the slave device. This START signal will be detected by all devices connected to the I²C bus. When detected, this indicates that the I²C bus is busy and therefore the HBB bit will be set. A START condition occurs when a high to low transition on the SDA line takes place when the SCL line remains high.

I²C Slave Address

The transmission of a START signal by the master will be detected by all devices on the I²C bus. To determine which slave device the master wishes to communicate with, the address of the slave device will be sent out immediately following the START signal. All slave devices, after receiving this 7-bit address data, will compare it with their own 7-bit slave address. If the address sent out by the master matches the internal address of the microcontroller slave device, then an internal I²C bus interrupt signal will be generated. The next bit following the address, which is the 8th bit, defines the read/write status and will be saved to the SRW bit of the IICC1 register. The slave device will then transmit an acknowledge bit, which is a low level, as the 9th bit. The slave device will also set the status flag HAAS when the addresses match.

As an I²C bus interrupt can come from three sources, when the program enters the interrupt subroutine, the HAAS and IICTOF bits should be examined to see whether the interrupt source has come from a matching slave address or from the completion of a data byte transfer or from the I²C bus time-out occurrence. When a slave address is matched, the device must be placed in either the transmit mode and then write data to the IICD register, or in the receive mode where it must implement a dummy read from the IICD register to release the SCL line.

I²C Bus Read/Write Signal

The SRW bit in the IICC1 register defines whether the master device wishes to read data from the I²C bus or write data to the I²C bus. The slave device should examine this bit to determine if it is to be a transmitter or a receiver. If the SRW flag is “1” then this indicates that the master device wishes to read data from the I²C bus, therefore the slave device must be setup to send data to the I²C bus as a transmitter. If the SRW flag is “0” then this indicates that the master wishes to send data to the I²C bus, therefore the slave device must be setup to read data from the I²C bus as a receiver.

I²C Bus Slave Address Acknowledge Signal

After the master has transmitted a calling address, any slave device on the I²C bus, whose own internal address matches the calling address, must generate an acknowledge signal. The acknowledge signal will inform the master that a slave device has accepted its calling address. If no acknowledge signal is received by the master then a STOP signal must be transmitted by the master to end the communication. When the HAAS flag is high, the addresses have matched and the slave device must check the SRW flag to determine if it is to be a transmitter or a receiver. If the SRW flag is high, the slave device should be setup to be a transmitter so the HTX bit in the IICC1 register should be set to “1”. If the SRW flag is low, then the microcontroller slave device should be setup as a receiver and the HTX bit in the IICC1 register should be set to “0”.

I²C Bus Data and Acknowledge Signal

The transmitted data is 8-bit wide and is transmitted after the slave device has acknowledged receipt of its slave address. The order of serial bit transmission is the MSB first and the LSB last. After receipt of 8 bits of data, the receiver must transmit an acknowledge signal, level “0”, before it can receive the next data byte. If the slave transmitter does not receive an acknowledge bit signal from the master receiver, then the slave transmitter will release the SDA line to allow the master to send a STOP signal to release the I²C Bus. The corresponding data will be stored in the IICD register.

If setup as a transmitter, the slave device must first write the data to be transmitted into the IICD register. If setup as a receiver, the slave device must read the transmitted data from the IICD register. When the slave receiver receives the data byte, it must generate an acknowledge bit, known as TXAK, on the 9th clock. The slave device, which is setup as a transmitter will check the RXAK bit in the IICC1 register to determine if it is to send another data byte, if not then it will release the SDA line and await the receipt of a STOP signal from the master.

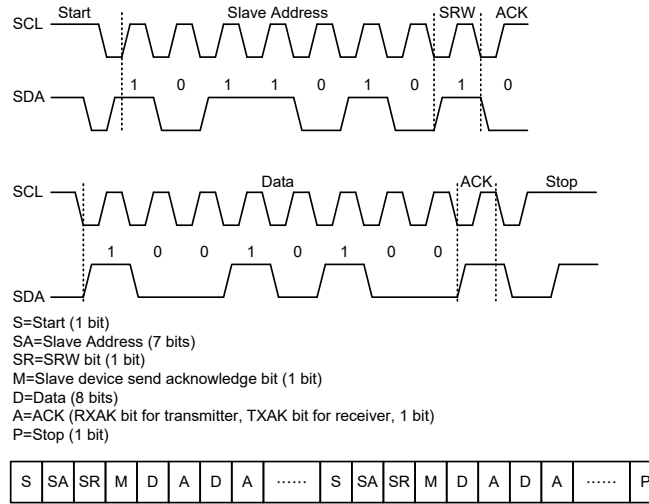

I²C Communication Timing Diagram

Note: When a slave address is matched, the device must be placed in either the transmit mode and then write data to the IICD register, or in the receive mode where it must implement a dummy read from the IICD register to release the SCL line.

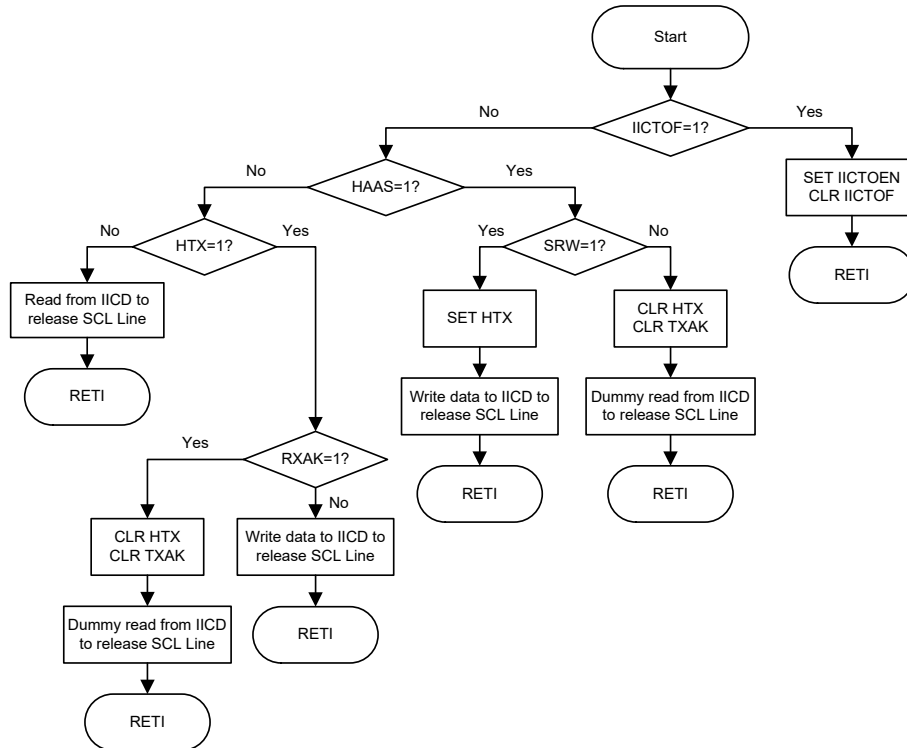

I²C Bus ISR Flowchart

I²C Time-out Control

In order to reduce the problem of I²C lockup due to reception of erroneous clock sources, a time-out function is provided. If the clock source to the I²C is not received for a while, then the I²C circuitry and registers will be reset after a certain time-out period. The time-out counter starts counting on an I²C bus “START” & “address match” condition, and is cleared by an SCL falling edge. Before the next SCL falling edge arrives, if the time elapsed is greater than the time-out setup by the IICTOC register, then a time-out condition will occur. The time-out function will stop when an I²C “STOP” condition occurs.

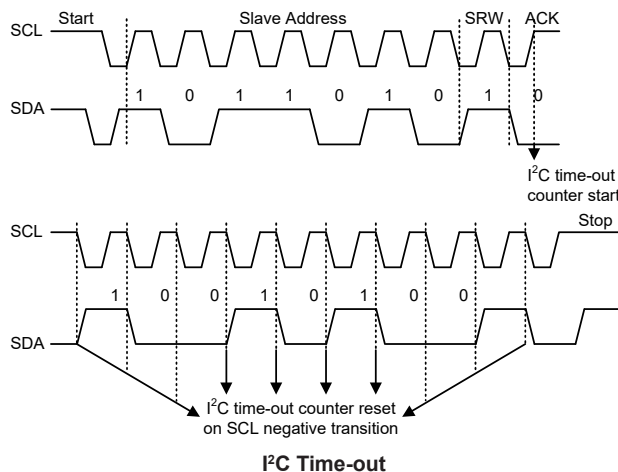

When an I²C time-out counter overflow occurs, the counter will stop and the IICTOEN bit will be cleared to zero and the IICTOF bit will be set high to indicate that a time-out condition has occurred. The time-out condition will also generate an interrupt which uses the I²C interrupt vector. When an I²C time-out occurs, the I²C internal circuitry will be reset and the registers will be reset into the following condition:

Registers	After I ² C Time-out
IICD, IICA, IICC0	No change
IICC1	Reset to POR condition

I²C Registers after Time-out

The IICTOF flag can be cleared by the application program. There are 64 time-out periods which can be selected using IICTOS bit field in the IICTOC register. The time-out time is given by the formula: $((1\sim64)\times32)/f_{SUB}$. This gives a time-out period which ranges from about 1ms to 64ms.

• IICTOC Register

Bit	7	6	5	4	3	2	1	0
Name	IICTOEN	IICTOF	IICTOS5	IICTOS4	IICTOS3	IICTOS2	IICTOS1	IICTOS0
R/W	R/W	R/W	R/W	R/W	R/W	R/W	R/W	R/W
POR	0	0	0	0	0	0	0	0

Bit 7 **IICTOEN**: I²C Time-out control
 0: Disable
 1: Enable

Bit 6 **IICTOF**: I²C Time-out flag
 0: No time-out occurred
 1: Time-out occurred

Bit 5~0 **IICTOS5~IICTOS0**: I²C Time-out period selection
 I²C time-out clock source is $f_{SUB}/32$.
 I²C time-out time is equal to $(IICTOS[5:0]+1)\times(32/f_{SUB})$.

Serial Interface Module – SIM – BS86D20C

The BS86D20C device contains a Serial Interface Module, which includes both the four line SPI interface and the two line I²C interface types, to allow an easy method of communication with external peripheral hardware. Having relatively simple communication protocols, these serial interface types allow the microcontroller to interface to external SPI or I²C based hardware such as sensors, Flash or EEPROM memory, etc. The SIM interface pins are pin-shared with other I/O pins therefore the SIM interface function must first be selected using the SIMEN bit in the SIMC0 register. As both interface types share the same pins and registers, the choice of whether the SPI or I²C type is used is made using the SIM operating mode control bits, named SIM2~SIM0, in the SIMC0 register. These pull-high resistors of the SIM pin-shared I/O are selected using pull-high control registers when the SIM function is enabled and the corresponding pins are used as SIM input pins.

SPI Interface

The SPI interface is often used to communicate with external peripheral devices such as sensors, Flash or EEPROM memory devices etc. Originally developed by Motorola, the four line SPI interface is a synchronous serial data interface that has a relatively simple communication protocol simplifying the programming requirements when communicating with external hardware devices.

The communication is full duplex and operates as a slave/master type, where the device can be either master or slave. Although the SPI interface specification can control multiple slave devices from a single master, but the device provides only one $\overline{\text{SCS}}$ pin. If the master needs to control multiple slave devices from a single master, the master can use I/O pin to select the slave devices.

SPI Interface Operation

The SPI interface is a full duplex synchronous serial data link. It is a four line interface with pin names SDI, SDO, SCK and $\overline{\text{SCS}}$. Pins SDI and SDO are the Serial Data Input and Serial Data Output lines, the SCK pin is the Serial Clock line and $\overline{\text{SCS}}$ is the Slave Select line. As the SPI interface pins are pin-shared with normal I/O pins and with the I²C function pins, the SPI interface pins must first be selected by setting the correct bits in the SIMC0 and SIMC2 registers. Communication between devices connected to the SPI interface is carried out in a slave/master mode with all data transfer initiations being implemented by the master. The Master also controls the clock signal. As the device only contains a single $\overline{\text{SCS}}$ pin only one slave device can be utilized. The $\overline{\text{SCS}}$ pin is controlled by software, set CSEN bit to 1 to enable $\overline{\text{SCS}}$ pin function, set CSEN bit to 0 the $\overline{\text{SCS}}$ pin will be floating state.

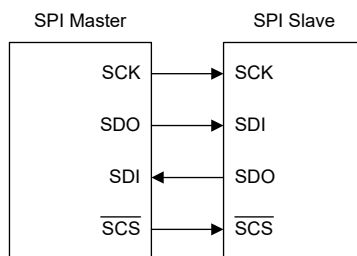

SPI Master/Slave Connection

The SPI function in the device offers the following features:

- Full duplex synchronous data transfer
- Both Master and Slave modes
- LSB first or MSB first data transmission modes
- Transmission complete flag
- Rising or falling active clock edge

The status of the SPI interface pins is determined by a number of factors such as whether the device is in the master or slave mode and upon the condition of certain control bits such as CSEN and SIMEN.

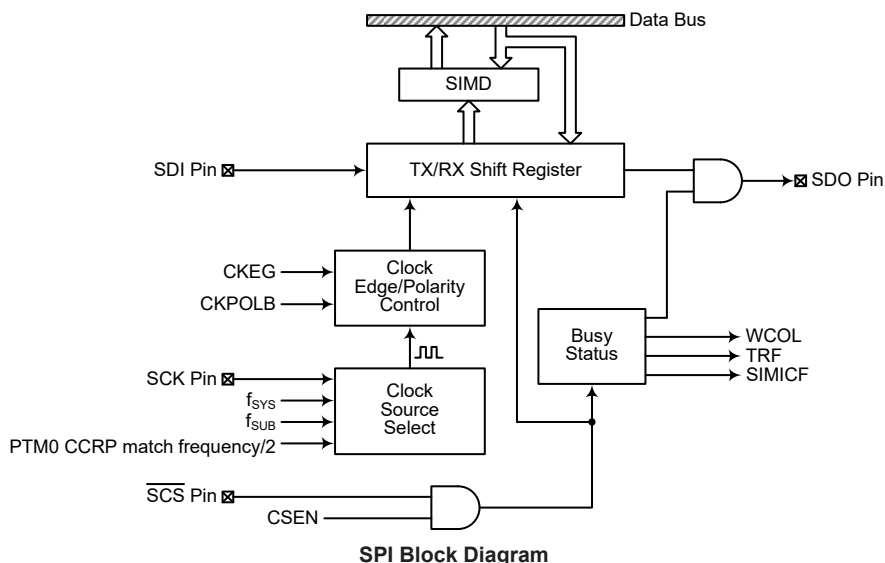

SPI Registers

There are three internal registers which control the overall operation of the SPI interface. These are the SIMD data register and two control registers, SIMC0 and SIMC2.

Register Name	Bit							
	7	6	5	4	3	2	1	0
SIMC0	SIM2	SIM1	SIM0	—	SIMDEB1	SIMDEB0	SIMEN	SIMICF
SIMC2	D7	D6	CKPOLB	CKEG	MLS	CSEN	WCOL	TRF
SIMD	D7	D6	D5	D4	D3	D2	D1	D0

SPI Register List

SPI Data Register

The SIMD register is used to store the data being transmitted and received. The same register is used by both the SPI and I²C functions. Before the device writes data to the SPI bus, the actual data to be transmitted must be placed in the SIMD register. After the data is received from the SPI bus, the device can read it from the SIMD register. Any transmission or reception of data from the SPI bus must be made via the SIMD register.

• SIMD Register

Bit	7	6	5	4	3	2	1	0
Name	D7	D6	D5	D4	D3	D2	D1	D0
R/W	R/W	R/W	R/W	R/W	R/W	R/W	R/W	R/W
POR	x	x	x	x	x	x	x	x

"x": unknown

Bit 7~0 **D7~D0**: SIM data register bit 7 ~ bit 0

SPI Control Registers

There are also two control registers for the SPI interface, SIMC0 and SIMC2. Note that the SIMC2 register also has the name SIMA which is used by the I²C function. The SIMC0 register is used to control the enable/disable function and to set the data transmission clock frequency. The SIMC2 register is used for other control functions such as LSB/MSB selection, write collision flag etc.

• SIMC0 Register

Bit	7	6	5	4	3	2	1	0
Name	SIM2	SIM1	SIM0	—	SIMDEB1	SIMDEB0	SIMEN	SIMICF
R/W	R/W	R/W	R/W	—	R/W	R/W	R/W	R/W
POR	1	1	1	—	0	0	0	0

Bit 7~5 **SIM2~SIM0**: SIM Operating Mode Control
 000: SPI master mode; SPI clock is $f_{SYS}/4$
 001: SPI master mode; SPI clock is $f_{SYS}/16$
 010: SPI master mode; SPI clock is $f_{SYS}/64$
 011: SPI master mode; SPI clock is f_{SUB}
 100: SPI master mode; SPI clock is PTM0 CCRP match frequency/2
 101: SPI slave mode
 110: I²C slave mode
 111: Unused mode

These bits setup the overall operating mode of the SIM function. As well as selecting if the I²C or SPI function, they are used to control the SPI Master/Slave selection and the SPI Master clock frequency. The SPI clock is a function of the system clock but can also be chosen to be sourced from PTM0 and f_{SUB} . If the SPI Slave Mode is selected then the clock will be supplied by an external Master device.

Bit 4 Unimplemented, read as “0”

Bit 3~2 **SIMDEB1~SIMDEB0**: I²C Debounce Time Selection

These bits are only available when the SIM is configured to operate in the I²C mode. Refer to the I²C register section.

Bit 1 **SIMEN**: SIM Enable Control

- 0: Disable
- 1: Enable

The bit is the overall on/off control for the SIM interface. When the SIMEN bit is cleared to zero to disable the SIM interface, the SDI, SDO, SCK and \overline{SCS} , or SDA and SCL lines will lose their SPI or I²C function and the SIM operating current will be reduced to a minimum value. When the bit is high the SIM interface is enabled. If the SIM is configured to operate as an SPI interface via the SIM2~SIM0 bits, the contents of the SPI control registers will remain at the previous settings when the SIMEN bit changes from low to high and should therefore be first initialised by the application program. If the SIM is configured to operate as an I²C interface via the SIM2~SIM0 bits and the SIMEN bit changes from low to high, the contents of the I²C control bits such as HTX and TXAK will remain at the previous settings and should therefore be first initialised by the application program while the relevant I²C flags such as HCF, HAAS, HBB, SRW and RXAK will be set to their default states.

Bit 0 **SIMICF**: SIM SPI Incomplete Flag

- 0: SIM SPI incomplete condition is not occurred
- 1: SIM SPI incomplete condition is occurred

This bit is only available when the SIM is configured to operate in an SPI slave mode. If the SPI operates in the slave mode with the SIMEN and CSEN bits both being set to 1 but the \overline{SCS} line is pulled high by the external master device before the SPI data transfer is completely finished, the SIMICF bit will be set to 1 together with the TRF bit. When this condition occurs, the corresponding interrupt will occur if the interrupt function is enabled. However, the TRF bit will not be set to 1 if the SIMICF bit is set to 1 by software application program.

• **SIMC2 Register**

Bit	7	6	5	4	3	2	1	0
Name	D7	D6	CKPOLB	CKEG	MLS	CSEN	WCOL	TRF
R/W	R/W	R/W	R/W	R/W	R/W	R/W	R/W	R/W
POR	0	0	0	0	0	0	0	0

- Bit 7~6 **D7~D6:** Undefined bits
 These bits can be read or written by the application program.
- Bit 5 **CKPOLB:** SPI clock line base condition selection
 0: The SCK line will be high when the clock is inactive
 1: The SCK line will be low when the clock is inactive
 The CKPOLB bit determines the base condition of the clock line, if the bit is high, then the SCK line will be low when the clock is inactive. When the CKPOLB bit is low, then the SCK line will be high when the clock is inactive.
- Bit 4 **CKEG:** SPI SCK clock active edge type selection
 CKPOLB=0
 0: SCK is high base level and data capture at SCK rising edge
 1: SCK is high base level and data capture at SCK falling edge
 CKPOLB=1
 0: SCK is low base level and data capture at SCK falling edge
 1: SCK is low base level and data capture at SCK rising edge
 The CKEG and CKPOLB bits are used to setup the way that the clock signal outputs and inputs data on the SPI bus. These two bits must be configured before data transfer is executed otherwise an erroneous clock edge may be generated. The CKPOLB bit determines the base condition of the clock line, if the bit is high, then the SCK line will be low when the clock is inactive. When the CKPOLB bit is low, then the SCK line will be high when the clock is inactive. The CKEG bit determines active clock edge type which depends upon the condition of CKPOLB bit.
- Bit 3 **MLS:** SPI data shift order
 0: LSB first
 1: MSB first
 This is the data shift select bit and is used to select how the data is transferred, either MSB or LSB first. Setting the bit high will select MSB first and low for LSB first.
- Bit 2 **CSEN:** SPI \overline{SCS} pin control
 0: Disable
 1: Enable
 The CSEN bit is used as an enable/disable for the \overline{SCS} pin. If this bit is low, then the \overline{SCS} pin will be disabled and placed into a floating condition. If the bit is high the SCS pin will be enabled and used as a select pin.
- Bit 1 **WCOL:** SPI write collision flag
 0: No collision
 1: Collision
 The WCOL flag is used to detect if a data collision has occurred. If this bit is high it means that data has been attempted to be written to the SIMD register during a data transfer operation. This writing operation will be ignored if data is being transferred. The bit can be cleared by the application program.
- Bit 0 **TRF:** SPI Transmit/Receive complete flag
 0: SPI data is being transferred
 1: SPI data transmission is completed
 The TRF bit is the Transmit/Receive Complete flag and is set “1” automatically when an SPI data transmission is completed, but must set to “0” by the application program. It can be used to generate an interrupt.

SPI Communication

After the SPI interface is enabled by setting the SIMEN bit high, then in the Master Mode, when data is written to the SIMD register, transmission/reception will begin simultaneously. When the data transfer is completed, the TRF flag will be set automatically, but must be cleared using the application program. In the Slave Mode, when the clock signal from the master has been received, any data in the SIMD register will be transmitted and any data on the SDI pin will be shifted into the SIMD register. The master should output an \overline{SCS} signal to enable the slave devices before a clock signal is provided. The slave data to be transferred should be well prepared at the appropriate moment relative to the SCK signal depending upon the configurations of the CKPOLB bit and CKEG bit. The accompanying timing diagram shows the relationship between the slave data and SCK signal for various configurations of the CKPOLB and CKEG bits.

The SPI will continue to function in certain IDLE Modes if the clock source used by the SPI interface is still active.

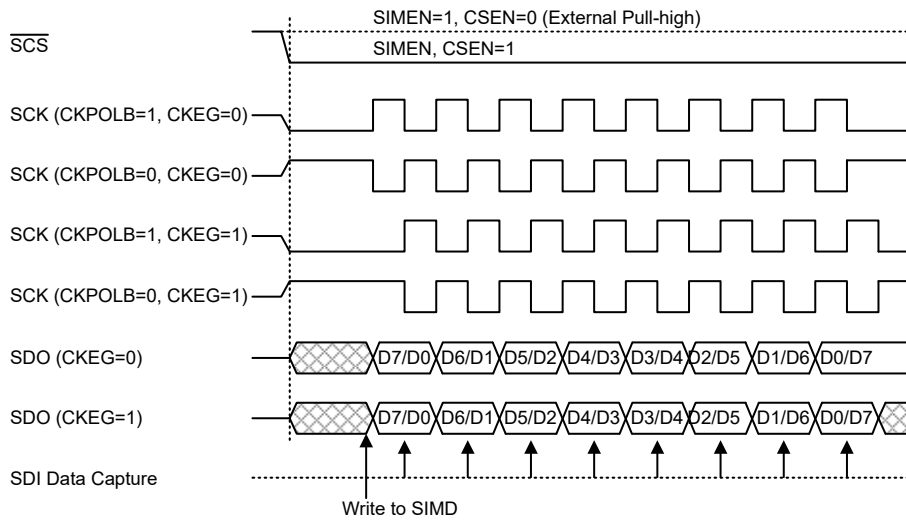

SPI Master Mode Timing

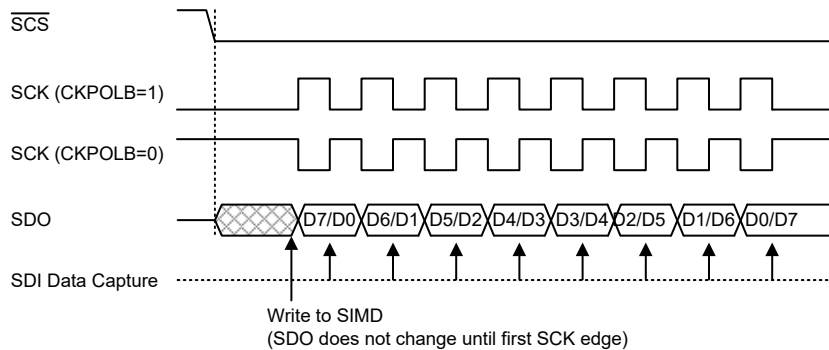

SPI Slave Mode Timing – CKEG=0

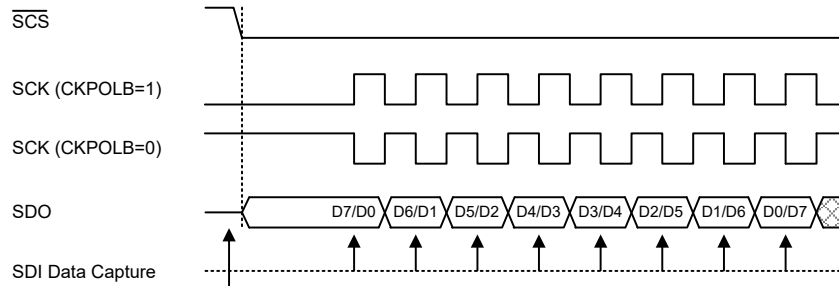

Write to SIMD
 (SDO changes as soon as writing occurs; SDO is floating if $\overline{SCS}=1$)

Note: For SPI slave mode, if SIMEN=1 and CSEN=0, SPI is always enabled and ignores the \overline{SCS} level.

SPI Slave Mode Timing – CKEG=1

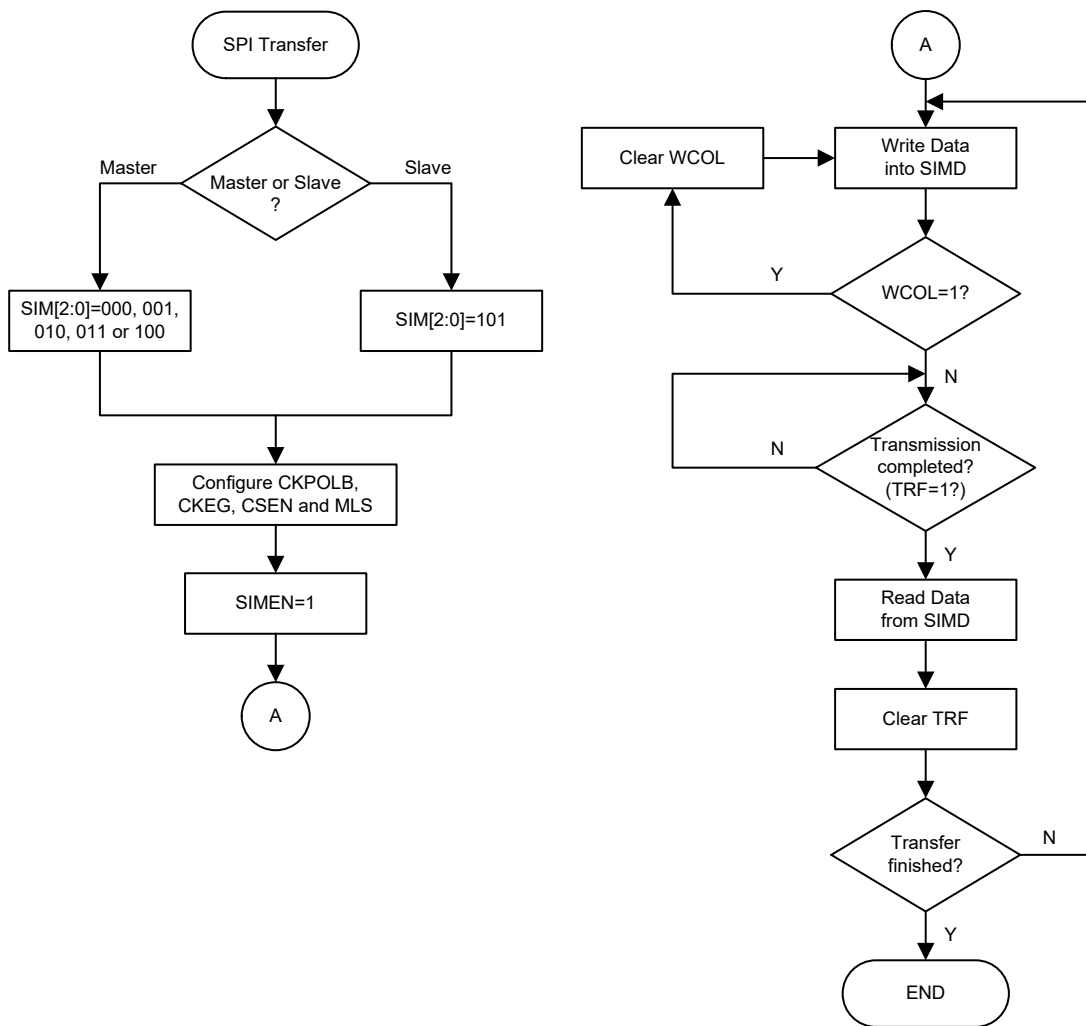

SPI Transfer Control Flowchart

SPI Bus Enable/Disable

To enable the SPI bus, set CSEN=1 and $\overline{\text{SCS}}=0$, then wait for data to be written into the SIMD (TXRX buffer) register. For the Master Mode, after data has been written to the SIMD (TXRX buffer) register, then transmission or reception will start automatically. When all the data has been transferred, the TRF bit should be set. For the Slave Mode, when clock pulses are received on SCK, data in the TXRX buffer will be shifted out or data on SDI will be shifted in.

When the SPI bus is disabled, SCK, SDI, SDO and $\overline{\text{SCS}}$ can become I/O pins or other pin-shared functions using the corresponding control bits.

SPI Operation Steps

All communication is carried out using the 4-line interface for either Master or Slave Mode.

The CSEN bit in the SIMC2 register controls the overall function of the SPI interface. Setting this bit high will enable the SPI interface by allowing the $\overline{\text{SCS}}$ line to be active, which can then be used to control the SPI interface. If the CSEN bit is low, the SPI interface will be disabled and the $\overline{\text{SCS}}$ line will be in a floating condition and can therefore not be used for control of the SPI interface. If the CSEN bit and the SIMEN bit in the SIMC0 are set high, this will place the SDI line in a floating condition and the SDO line high. If in Master Mode the SCK line will be either high or low depending upon the clock polarity selection bit CKPOLB in the SIMC2 register. If in Slave Mode the SCK line will be in a floating condition. If the SIMEN bit is low, then the bus will be disabled and $\overline{\text{SCS}}$, SDI, SDO and SCK will all become I/O pins or the other functions using the corresponding control bits. In the Master Mode the Master will always generate the clock signal. The clock and data transmission will be initiated after data has been written into the SIMD register. In the Slave Mode, the clock signal will be received from an external master device for both data transmission and reception. The following sequences show the order to be followed for data transfer in both Master and Slave Mode.

Master Mode

- Step 1
Select the SPI Master mode and clock source using the SIM2~SIM0 bits in the SIMC0 control register.
- Step 2
Setup the CSEN bit and setup the MLS bit to choose if the data is MSB or LSB first, this setting must be the same with the Slave devices.
- Step 3
Setup the SIMEN bit in the SIMC0 control register to enable the SPI interface.
- Step 4
For write operations: write the data to the SIMD register, which will actually place the data into the TXRX buffer. Then use the SCK and SDO lines to output the data. After this, go to step 5.
For read operations: the data transferred in on the SDI line will be stored in the TXRX buffer until all the data has been received at which point it will be latched into the SIMD register.
- Step 5
Check the WCOL bit if set high then a collision error has occurred so return to step 4. If equal to zero then go to the following step.
- Step 6
Check the TRF bit or wait for a SPI serial bus interrupt.
- Step 7
Read data from the SIMD register.

- Step 8
Clear TRF.
- Step 9
Go to step 4.

Slave Mode

- Step 1
Select the SPI Slave mode using the SIM2~SIM0 bits in the SIMC0 control register
- Step 2
- Setup the CSEN bit and setup the MLS bit to choose if the data is MSB or LSB first, this setting must be the same with the Master devices.
- Step 3
Setup the SIMEN bit in the SIMC0 control register to enable the SPI interface.
- Step 4
For write operations: write the data to the SIMD register, which will actually place the data into the TXRX buffer. Then wait for the master clock SCK and \overline{SCS} signal. After this, go to step 5.
For read operations: the data transferred in on the SDI line will be stored in the TXRX buffer until all the data has been received at which point it will be latched into the SIMD register.
- Step 5
Check the WCOL bit if set high then a collision error has occurred so return to step 4. If equal to zero then go to the following step.
- Step 6
Check the TRF bit or wait for a SPI serial bus interrupt.
- Step 7
Read data from the SIMD register.
- Step 8
Clear TRF.
- Step 9
Go to step 4.

Error Detection

The WCOL bit in the SIMC2 register is provided to indicate errors during data transfer. The bit is set by the SPI serial Interface but must be cleared by the application program. This bit indicates that a data collision has occurred which happens if a write to the SIMD register takes place during a data transfer operation and will prevent the write operation from continuing.

I²C Interface

The I²C interface is used to communicate with external peripheral devices such as sensors, EEPROM memory etc. Originally developed by Philips, it is a two line low speed serial interface for synchronous serial data transfer. The advantage of only two lines for communication, relatively simple communication protocol and the ability to accommodate multiple devices on the same bus has made it an extremely popular interface type for many applications.

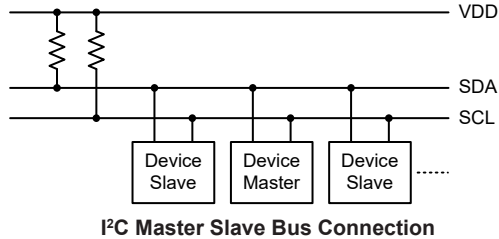

I²C Interface Operation

The I²C serial interface is a two line interface, a serial data line, SDA, and serial clock line, SCL. As many devices may be connected together on the same bus, their outputs are both open drain types. For this reason it is necessary that external pull-high resistors are connected to these outputs. Note that no chip select line exists, as each device on the I²C bus is identified by a unique address which will be transmitted and received on the I²C bus.

When two devices communicate with each other on the bidirectional I²C bus, one is known as the master device and one as the slave device. Both master and slave can transmit and receive data, however, it is the master device that has overall control of the bus. For the device, which only operates in slave mode, there are two methods of transferring data on the I²C bus, the slave transmit mode and the slave receive mode. It is suggested that the device shall not enter the IDLE or SLEEP mode during the I²C communication is in progress. The pull-high control function pin-shared with SCL/SDA pin is still applicable even if I²C device is activated and the related internal pull-high function could be controlled by its corresponding pull-high control register.

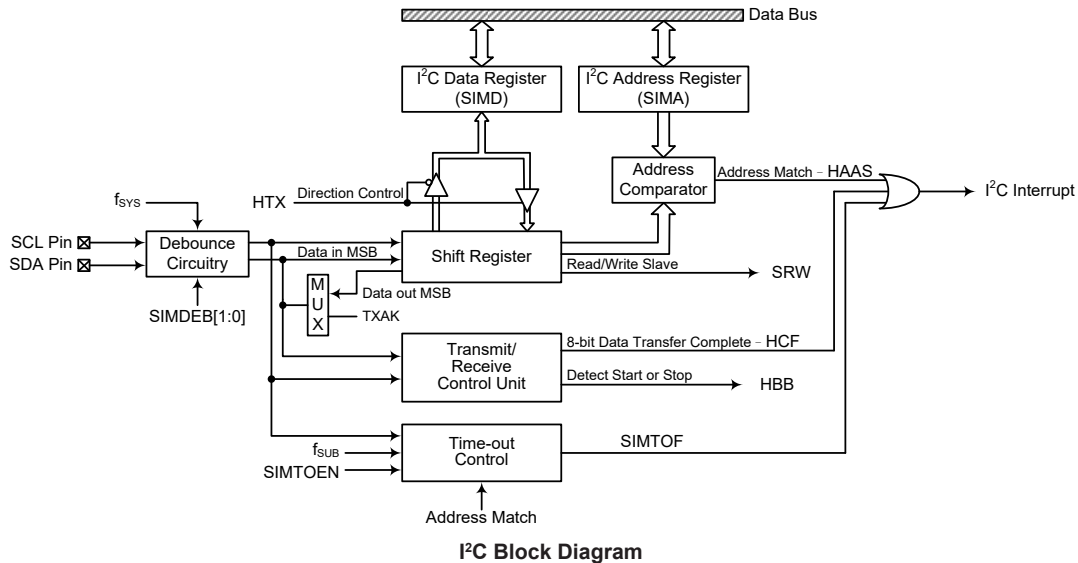

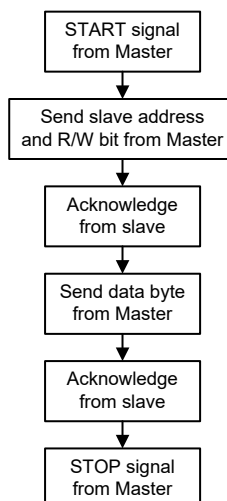

I²C Interface Operation

The SIMDEB1 and SIMDEB0 bits determine the debounce time of the I²C interface. This uses the internal clock to in effect add a debounce time to the external clock to reduce the possibility of glitches on the clock line causing erroneous operation. The debounce time, if selected, can be chosen to be either 2 or 4 system clocks. To achieve the required I²C data transfer speed, there exists a relationship between the system clock, f_{SYS} , and the I²C debounce time. For either the I²C Standard or Fast mode operation, users must take care of the selected system clock frequency and the configured debounce time to match the criterion shown in the following table.

I ² C Debounce Time Selection	I ² C Standard Mode (100kHz)	I ² C Fast Mode (400kHz)
No Debounce	$f_{SYS} > 2\text{MHz}$	$f_{SYS} > 5\text{MHz}$
2 system clock debounce	$f_{SYS} > 4\text{MHz}$	$f_{SYS} > 10\text{MHz}$
4 system clock debounce	$f_{SYS} > 8\text{MHz}$	$f_{SYS} > 20\text{MHz}$

I²C Minimum f_{SYS} Frequency Requirements

I²C Registers

There are three control registers associated with the I²C bus, SIMC0, SIMC1 and SIMTOC, one address register SIMA and one data register, SIMD.

Register Name	Bit							
	7	6	5	4	3	2	1	0
SIMC0	SIM2	SIM1	SIM0	—	SIMDEB1	SIMDEB0	SIMEN	SIMICF
SIMC1	HCF	HAAS	HBB	HTX	TXAK	SRW	IAMWU	RXAK
SIMD	D7	D6	D5	D4	D3	D2	D1	D0
SIMA	SIMA6	SIMA5	SIMA4	SIMA3	SIMA2	SIMA1	SIMA0	D0
SIMTOC	SIMTOEN	SIMTOF	SIMTOS5	SIMTOS4	SIMTOS3	SIMTOS2	SIMTOS1	SIMTOS0

I²C Register List

I²C Data Register

The SIMD register is used to store the data being transmitted and received. The same register is used by both the SPI and I²C functions. Before the device writes data to the I²C bus, the actual data to be transmitted must be placed in the SIMD register. After the data is received from the I²C bus, the device can read it from the SIMD register. Any transmission or reception of data from the I²C bus must be made via the SIMD register.

• **SIMD Register**

Bit	7	6	5	4	3	2	1	0
Name	D7	D6	D5	D4	D3	D2	D1	D0
R/W	R/W	R/W	R/W	R/W	R/W	R/W	R/W	R/W
POR	x	x	x	x	x	x	x	x

“x”: unknown

Bit 7~0 **D7~D0**: SIM data register bit 7 ~ bit 0

I²C Address Register

The SIMA register is also used by the SPI interface but has the name SIMC2. The SIMA register is the location where the 7-bit slave address of the slave device is stored. Bits 7~1 of the SIMA register define the device slave address. Bit 0 is not defined. When a master device, which is connected to the I²C bus, sends out an address, which matches the slave address in the SIMA register, the slave device will be selected. Note that the SIMA register is the same register address as SIMC2 which is used by the SPI interface.

• **SIMA Register**

Bit	7	6	5	4	3	2	1	0
Name	SIMA6	SIMA5	SIMA4	SIMA3	SIMA2	SIMA1	SIMA0	D0
R/W	R/W	R/W	R/W	R/W	R/W	R/W	R/W	R/W
POR	0	0	0	0	0	0	0	0

Bit 7~1 **SIMA6~SIMA0**: I²C slave address
 SIMA6~SIMA0 is the I²C slave address bit 6 ~ bit 0.

Bit 0 **D0**: Reserved bit, can be read or written by application program

I²C Control Registers

There are three control registers for the I²C interface, SIMC0, SIMC1 and SIMTOC. The SIMC0 register is used to control the enable/disable function and to set the data transmission clock frequency. The SIMC1 register contains the relevant flags which are used to indicate the I²C communication status. Another register, SIMTOC, is used to control the I²C time-out function and is described in the corresponding section.

• **SIMC0 Register**

Bit	7	6	5	4	3	2	1	0
Name	SIM2	SIM1	SIM0	—	SIMDEB1	SIMDEB0	SIMEN	SIMICF
R/W	R/W	R/W	R/W	—	R/W	R/W	R/W	R/W
POR	1	1	1	—	0	0	0	0

Bit 7~5 **SIM2~SIM0**: SIM Operating Mode Control
 000: SPI master mode; SPI clock is $f_{SYS}/4$
 001: SPI master mode; SPI clock is $f_{SYS}/16$
 010: SPI master mode; SPI clock is $f_{SYS}/64$
 011: SPI master mode; SPI clock is f_{SUB}
 100: SPI master mode; SPI clock is PTM0 CCRP match frequency/2
 101: SPI slave mode
 110: I²C slave mode
 111: Unused mode

These bits setup the overall operating mode of the SIM function. As well as selecting if the I²C or SPI function, they are used to control the SPI Master/Slave selection and the SPI Master clock frequency. The SPI clock is a function of the system clock but can also be chosen to be sourced from PTM0 and f_{SUB} . If the SPI Slave Mode is selected then the clock will be supplied by an external Master device.

- Bit 4 Unimplemented, read as “0”
- Bit 3~2 **SIMDEB1~SIMDEB0**: I²C Debounce Time Selection
 00: No debounce
 01: 2 system clock debounce
 1x: 4 system clock debounce
- These bits are used to select the I²C debounce time when the SIM is configured as the I²C interface function by setting the SIM2~SIM0 bits to “110”.
- Bit 1 **SIMEN**: SIM Enable Control
 0: Disable
 1: Enable
- The bit is the overall on/off control for the SIM interface. When the SIMEN bit is cleared to zero to disable the SIM interface, the SDI, SDO, SCK and \overline{SCS} , or SDA and SCL lines will lose their SPI or I²C function and the SIM operating current will be reduced to a minimum value. When the bit is high the SIM interface is enabled. If the SIM is configured to operate as an SPI interface via the SIM2~SIM0 bits, the contents of the SPI control registers will remain at the previous settings when the SIMEN bit changes from low to high and should therefore be first initialised by the application program. If the SIM is configured to operate as an I²C interface via the SIM2~SIM0 bits and the SIMEN bit changes from low to high, the contents of the I²C control bits such as HTX and TXAK will remain at the previous settings and should therefore be first initialised by the application program while the relevant I²C flags such as HCF, HAAS, HBB, SRW and RXAK will be set to their default states.
- Bit 0 **SIMICF**: SIM SPI Incomplete Flag
 This bit is only available when the SIM is configured to operate in an SPI slave mode. Refer to the SPI register section.

• **SIMC1 Register**

Bit	7	6	5	4	3	2	1	0
Name	HCF	HAAS	HBB	HTX	TXAK	SRW	IAMWU	RXAK
R/W	R	R	R	R/W	R/W	R	R/W	R
POR	1	0	0	0	0	0	0	1

- Bit 7 **HCF**: I²C Bus data transfer completion flag
 0: Data is being transferred
 1: Completion of an 8-bit data transfer
- The HCF flag is the data transfer flag. This flag will be zero when data is being transferred. Upon completion of an 8-bit data transfer the flag will go high and an interrupt will be generated.
- Bit 6 **HAAS**: I²C Bus address match flag
 0: Not address match
 1: Address match
- The HAAS flag is the address match flag. This flag is used to determine if the slave device address is the same as the master transmit address. If the addresses match then this bit will be high, if there is no match then the flag will be low.
- Bit 5 **HBB**: I²C Bus busy flag
 0: I²C Bus is not busy
 1: I²C Bus is busy
- The HBB flag is the I²C busy flag. This flag will be “1” when the I²C bus is busy which will occur when a START signal is detected. The flag will be set to “0” when the bus is free which will occur when a STOP signal is detected.
- Bit 4 **HTX**: I²C slave device is transmitter or receiver selection
 0: Slave device is the receiver
 1: Slave device is the transmitter

Bit 3	<p>TXAK: I²C Bus transmit acknowledge flag 0: Slave send acknowledge flag 1: Slave do not send acknowledge flag</p> <p>The TXAK bit is the transmit acknowledge flag. After the slave device receipt of 8 bits of data, this bit will be transmitted to the bus on the 9th clock from the slave device. The slave device must always set TXAK bit to “0” before further data is received.</p>
Bit 2	<p>SRW: I²C Slave Read/Write flag 0: Slave device should be in receive mode 1: Slave device should be in transmit mode</p> <p>The SRW flag is the I²C Slave Read/Write flag. This flag determines whether the master device wishes to transmit or receive data from the I²C bus. When the transmitted address and slave address is match, that is when the HAAS flag is set high, the slave device will check the SRW flag to determine whether it should be in transmit mode or receive mode. If the SRW flag is high, the master is requesting to read data from the bus, so the slave device should be in transmit mode. When the SRW flag is zero, the master will write data to the bus, therefore the slave device should be in receive mode to read this data.</p>
Bit 1	<p>IAMWU: I²C Address Match Wake-up control 0: Disable 1: Enable</p> <p>This bit should be set to 1 to enable the I²C address match wake up from the SLEEP or IDLE Mode. If the IAMWU bit has been set before entering either the SLEEP or IDLE mode to enable the I²C address match wake up, then this bit must be cleared by the application program after wake-up to ensure correction device operation.</p>
Bit 0	<p>RXAK: I²C Bus Receive acknowledge flag 0: Slave receive acknowledge flag 1: Slave does not receive acknowledge flag</p> <p>The RXAK flag is the receiver acknowledge flag. When the RXAK flag is “0”, it means that a acknowledge signal has been received at the 9th clock, after 8 bits of data have been transmitted. When the slave device in the transmit mode, the slave device checks the RXAK flag to determine if the master receiver wishes to receive the next byte. The slave transmitter will therefore continue sending out data until the RXAK flag is “1”. When this occurs, the slave transmitter will release the SDA line to allow the master to send a STOP signal to release the I²C Bus.</p>

I²C Bus Communication

Communication on the I²C bus requires four separate steps, a START signal, a slave device address transmission, a data transmission and finally a STOP signal. When a START signal is placed on the I²C bus, all devices on the bus will receive this signal and be notified of the imminent arrival of data on the bus. The first seven bits of the data will be the slave address with the first bit being the MSB. If the address of the slave device matches that of the transmitted address, the HAAS bit in the SIMC1 register will be set and an I²C interrupt will be generated. After entering the interrupt service routine, the slave device must first check the condition of the HAAS and SIMTOF bits to determine whether the interrupt source originates from an address match or from the completion of an 8-bit data transfer completion or from the I²C bus time-out occurrence. During a data transfer, note that after the 7-bit slave address has been transmitted, the following bit, which is the 8th bit, is the read/write bit whose value will be placed in the SRW bit. This bit will be checked by the slave device to determine whether to go into transmit or receive mode. Before any transfer of data to or from the I²C bus, the microcontroller must initialise the bus, the following are steps to achieve this:

- Step 1
 Set the SIM2~SIM0 and SIMEN bits in the SIMC0 register to “110” and “1” respectively to enable the I²C bus.

- Step 2
Write the slave address of the device to the I²C bus address register SIMA.
- Step 3
Set the SIME interrupt enable bit of the interrupt control register to enable the SIM interrupt.

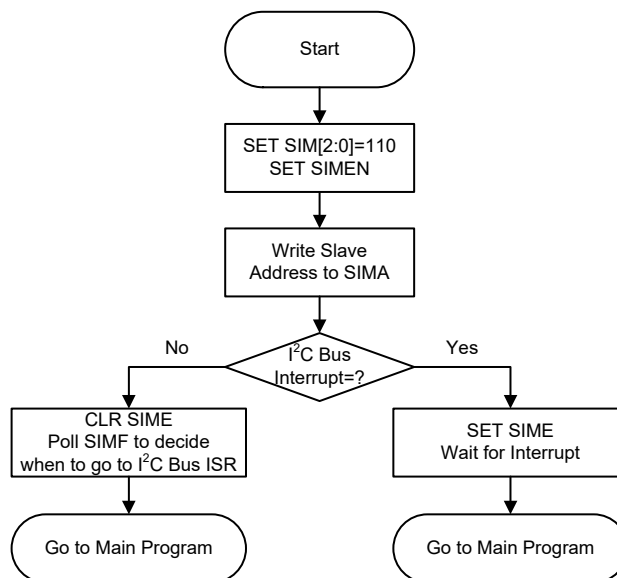

I²C Bus Initialisation Flow Chart

I²C Bus Start Signal

The START signal can only be generated by the master device connected to the I²C bus and not by the slave device. This START signal will be detected by all devices connected to the I²C bus. When detected, this indicates that the I²C bus is busy and therefore the HBB bit will be set. A START condition occurs when a high to low transition on the SDA line takes place when the SCL line remains high.

I²C Slave Address

The transmission of a START signal by the master will be detected by all devices on the I²C bus. To determine which slave device the master wishes to communicate with, the address of the slave device will be sent out immediately following the START signal. All slave devices, after receiving this 7-bit address data, will compare it with their own 7-bit slave address. If the address sent out by the master matches the internal address of the microcontroller slave device, then an internal I²C bus interrupt signal will be generated. The next bit following the address, which is the 8th bit, defines the read/write status and will be saved to the SRW bit of the SIMC1 register. The slave device will then transmit an acknowledge bit, which is a low level, as the 9th bit. The slave device will also set the status flag HAAS when the addresses match.

As an I²C bus interrupt can come from three sources, when the program enters the interrupt subroutine, the HAAS and SIMTOF bits should be examined to see whether the interrupt source has come from a matching slave address or from the completion of a data byte transfer or from the I²C bus time-out occurrence. When a slave address is matched, the device must be placed in either the transmit mode and then write data to the SIMD register, or in the receive mode where it must implement a dummy read from the SIMD register to release the SCL line.

I²C Bus Read/Write Signal

The SRW bit in the SIMC1 register defines whether the master device wishes to read data from the I²C bus or write data to the I²C bus. The slave device should examine this bit to determine if it is to be a transmitter or a receiver. If the SRW flag is “1” then this indicates that the master device wishes to read data from the I²C bus, therefore the slave device must be setup to send data to the I²C bus as a transmitter. If the SRW flag is “0” then this indicates that the master wishes to send data to the I²C bus, therefore the slave device must be setup to read data from the I²C bus as a receiver.

I²C Bus Slave Address Acknowledge Signal

After the master has transmitted a calling address, any slave device on the I²C bus, whose own internal address matches the calling address, must generate an acknowledge signal. The acknowledge signal will inform the master that a slave device has accepted its calling address. If no acknowledge signal is received by the master then a STOP signal must be transmitted by the master to end the communication. When the HAAS flag is high, the addresses have matched and the slave device must check the SRW flag to determine if it is to be a transmitter or a receiver. If the SRW flag is high, the slave device should be setup to be a transmitter so the HTX bit in the SIMC1 register should be set to “1”. If the SRW flag is low, then the microcontroller slave device should be setup as a receiver and the HTX bit in the SIMC1 register should be set to “0”.

I²C Bus Data and Acknowledge Signal

The transmitted data is 8-bit wide and is transmitted after the slave device has acknowledged receipt of its slave address. The order of serial bit transmission is the MSB first and the LSB last. After receipt of 8 bits of data, the receiver must transmit an acknowledge signal, level “0”, before it can receive the next data byte. If the slave transmitter does not receive an acknowledge bit signal from the master receiver, then the slave transmitter will release the SDA line to allow the master to send a STOP signal to release the I²C Bus. The corresponding data will be stored in the SIMD register. If setup as a transmitter, the slave device must first write the data to be transmitted into the SIMD register. If setup as a receiver, the slave device must read the transmitted data from the SIMD register.

When the slave receiver receives the data byte, it must generate an acknowledge bit, known as TXAK, on the 9th clock. The slave device, which is setup as a transmitter will check the RXAK bit in the SIMC1 register to determine if it is to send another data byte, if not then it will release the SDA line and await the receipt of a STOP signal from the master.

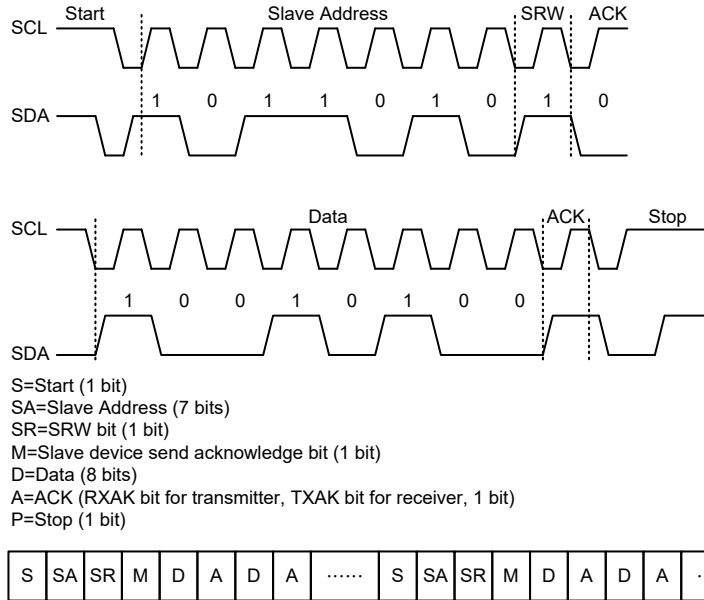

I²C Communication Timing Diagram

Note: When a slave address is matched, the device must be placed in either the transmit mode and then write data to the SIMD register, or in the receive mode where it must implement a dummy read from the SIMD register to release the SCL line.

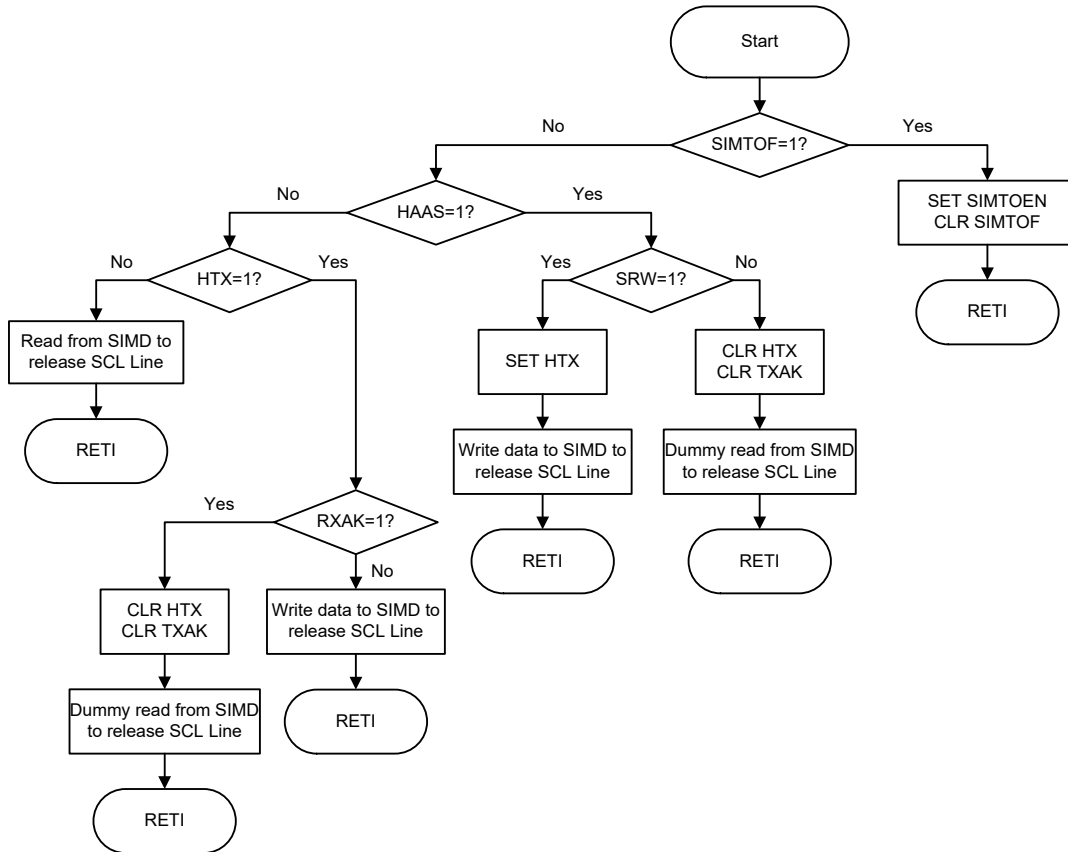

I²C Bus ISR Flow Chart

I²C Time-out Control

In order to reduce the problem of I²C lockup due to reception of erroneous clock sources, a time-out function is provided. If the clock source to the I²C is not received for a while, then the I²C circuitry and registers will be reset after a certain time-out period. The time-out counter starts counting on an I²C bus “START” & “address match” condition, and is cleared by an SCL falling edge. Before the next SCL falling edge arrives, if the time elapsed is greater than the time-out setup by the SIMTOC register, then a time-out condition will occur. The time-out function will stop when an I²C “STOP” condition occurs.

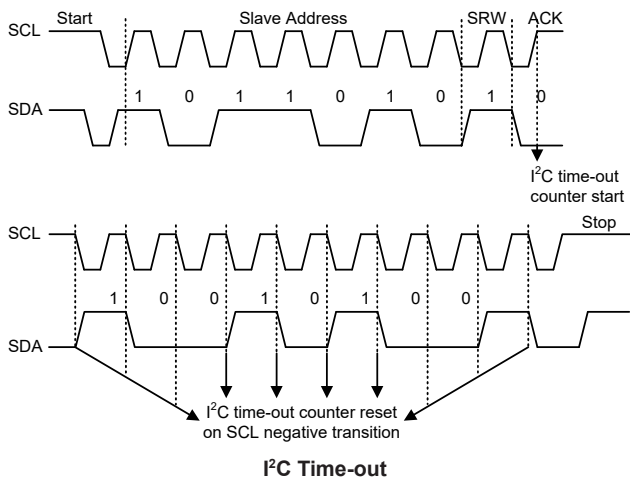

When an I²C time-out counter overflow occurs, the counter will stop and the SIMTOEN bit will be cleared to zero and the SIMTOF bit will be set high to indicate that a time-out condition has occurred. The time-out condition will also generate an interrupt which uses the I²C interrupt vector. When an I²C time-out occurs, the I²C internal circuitry will be reset and the registers will be reset into the following condition:

Registers	After I ² C Time-out
SIMD, SIMA, SIMC0	No change
SIMC1	Reset to POR condition

I²C Registers after Time-out

The SIMTOF flag can be cleared by the application program. There are 64 time-out periods which can be selected using SIMTOS bit field in the SIMTOC register. The time-out time is given by the formula: $((1\sim64)\times 32)/f_{SUB}$. This gives a time-out period which ranges from about 1ms to 64ms.

• SIMTOC Register

Bit	7	6	5	4	3	2	1	0
Name	SIMTOEN	SIMTOF	SIMTOS5	SIMTOS4	SIMTOS3	SIMTOS2	SIMTOS1	SIMTOS0
R/W	R/W	R/W	R/W	R/W	R/W	R/W	R/W	R/W
POR	0	0	0	0	0	0	0	0

Bit 7 **SIMTOEN**: SIM I²C Time-out control
 0: Disable
 1: Enable

Bit 6 **SIMTOF**: SIM I²C Time-out flag
 0: No time-out occurred
 1: Time-out occurred

Bit 5~0 **SIMTOS5~SIMTOS0**: SIM I²C Time-out period selection
 I²C time-out clock source is $f_{SUB}/32$.
 I²C time-out time is equal to $(SIMTOS[5:0]+1)\times(32/f_{SUB})$.

UART Interfaces

These devices contain up to two integrated full-duplex asynchronous serial communications UART interfaces that enable communication with external devices that contain a serial interface. Each UART function has many features and can transmit and receive data serially by transferring a frame of data with eight or nine data bits per transmission as well as being able to detect errors when the data is overwritten or incorrectly framed. Each UART function possesses its own internal interrupt which can be used to indicate when a reception occurs or when a transmission terminates.

Device	UART
BS86C08C BS86D12C BS86D20C	UART0
BS86E16C	UART0, UART1

The integrated UART functions contain the following features:

- Full-duplex, asynchronous communication
- 8 or 9 bits character length
- Even, odd or no parity options
- One or two stop bits
- Baud rate generator with 8-bit prescaler
- Parity, framing, noise and overrun error detection
- Support for interrupt on address detect (last character bit=1)
- Separately enabled transmitter and receiver
- 2-byte Deep FIFO Receive Data Buffer
- RXn pin wake-up function
- Transmit and receive interrupts
- Interrupts can be initialized by the following conditions:
 - ♦ Transmitter Empty
 - ♦ Transmitter Idle
 - ♦ Receiver Full
 - ♦ Receiver Overrun
 - ♦ Address Mode Detect

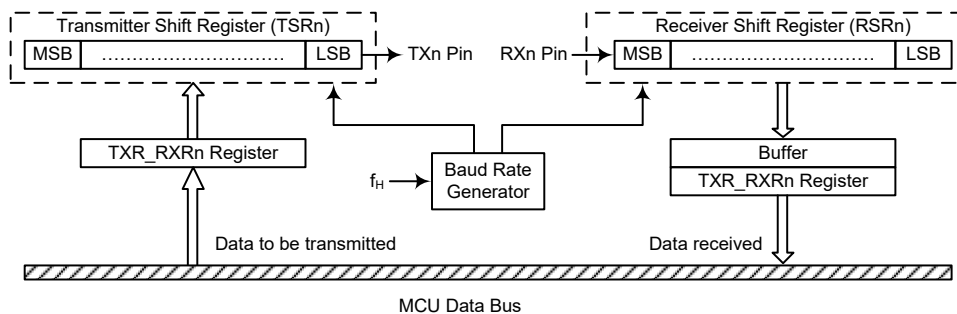

UARTn Data Transfer Block Diagram (n=0~1)

UARTn External Pins

To communicate with an external serial interface, the internal UARTn has two external pins known as TXn and RXn. The TXn and RXn pins are the UART transmitter and receiver pins respectively. Along with the UARTENn bit, the TXENn and RXENn bits, if set, will setup these pins to their respective TXn output and RXn input conditions and disable any pull-high resistor option which may exist on the TXn pin. However, the pull-high resistor related to the RXn pin is controlled by the corresponding I/O pull-high function control bit. However, the RXn pin function should first be selected by the corresponding pin-shared function control bit, RXnEN, in the IFS2 register before the UARTn function is used. When the TXn or RXn pin function is disabled by clearing the UARTENn, TXENn or RXENn bit, the TXn or RXn pin will be placed into a floating state. At this time whether the internal pull-high resistor is connected to the TXn or RXn pin or not is determined by the corresponding I/O pull-high function control bit.

UARTn Data Transfer Scheme

The above block diagram shows the overall data transfer structure arrangement for the UARTn. The actual data to be transmitted from the MCU is first transferred to the TXR_RXRn register by the application program. The data will then be transferred to the Transmit Shift Register from where it will be shifted out, LSB first, onto the TXn pin at a rate controlled by the Baud Rate Generator. Only the TXR_RXRn register is mapped onto the MCU Data Memory, the Transmit Shift Register is not mapped and is therefore inaccessible to the application program.

Data to be received by the UARTn is accepted on the external RXn pin, from where it is shifted in, LSB first, to the Receiver Shift Register at a rate controlled by the Baud Rate Generator. When the shift register is full, the data will then be transferred from the shift register to the internal TXR_RXRn register, where it is buffered and can be manipulated by the application program. Only the TXR_RXRn register is mapped onto the MCU Data Memory, the Receiver Shift Register is not mapped and is therefore inaccessible to the application program.

It should be noted that the actual register for data transmission and reception only exists as a single shared register in the Data Memory. This shared register known as the TXR_RXRn register is used for both data transmission and data reception.

UARTn Status and Control Registers

There are five control registers associated with the UARTn function. The UnSR, UnCR1 and UnCR2 registers control the overall function of the UARTn, while the BRGn register controls the Baud rate. The actual data to be transmitted and received on the serial interface is managed through the TXR_RXRn data register.

Register Name	Bit							
	7	6	5	4	3	2	1	0
UnSR	PERRn	NFn	FERRn	OERRn	RIDLEn	RXIFn	TIDLEn	TXIFn
UnCR1	UARTENn	BNOn	PRENn	PRTn	STOPSn	TXBRKn	RX8n	TX8n
UnCR2	TXENn	RXENn	BRGHn	ADDENn	WAKEn	RIEn	TIIEn	TEIEn
TXR_RXRn	TXRXn7	TXRXn6	TXRXn5	TXRXn4	TXRXn3	TXRXn2	TXRXn1	TXRXn0
BRGn	BRGn7	BRGn6	BRGn5	BRGn4	BRGn3	BRGn2	BRGn1	BRGn0

UARTn Register List (n=0~1)

• **UnSR Register**

The UnSR register is the status register for the UARTn, which can be read by the program to determine the present status of the UARTn. All flags within the UnSR register are read only. Further explanation on each of the flags is given below:

Bit	7	6	5	4	3	2	1	0
Name	PERRn	NFn	FERRn	OERRn	RIDLEn	RXIFn	TIDLEn	TXIFn
R/W	R	R	R	R	R	R	R	R
POR	0	0	0	0	1	0	1	1

- Bit 7 PERRn:** Parity error flag
 0: No parity error is detected
 1: Parity error is detected
 The PERRn flag is the parity error flag. When this read only flag is “0”, it indicates a parity error has not been detected. When the flag is “1”, it indicates that the parity of the received word is incorrect. This error flag is applicable only if Parity mode (odd or even) is selected. The flag can also be cleared by a software sequence which involves a read to the status register UnSR followed by an access to the TXR_RXRn data register.
- Bit 6 NFn:** Noise flag
 0: No noise is detected
 1: Noise is detected
 The NFn flag is the noise flag. When this read only flag is “0”, it indicates no noise condition. When the flag is “1”, it indicates that the UARTn has detected noise on the receiver input. The NFn flag is set during the same cycle as the RXIFn flag but will not be set in the case of an overrun. The NFn flag can be cleared by a software sequence which will involve a read to the status register UnSR followed by an access to the TXR_RXRn data register.
- Bit 5 FERRn:** Framing error flag
 0: No framing error is detected
 1: Framing error is detected
 The FERRn flag is the framing error flag. When this read only flag is “0”, it indicates that there is no framing error. When the flag is “1”, it indicates that a framing error has been detected for the current character. The flag can also be cleared by a software sequence which will involve a read to the status register UnSR followed by an access to the TXR_RXRn data register.
- Bit 4 OERRn:** Overrun error flag
 0: No overrun error is detected
 1: Overrun error is detected
 The OERRn flag is the overrun error flag which indicates when the receiver buffer has overflowed. When this read only flag is “0”, it indicates that there is no overrun error. When the flag is “1”, it indicates that an overrun error occurs which will inhibit further transfers to the TXR_RXRn receive data register. The flag is cleared by a software sequence, which is a read to the status register UnSR followed by an access to the TXR_RXRn data register.
- Bit 3 RIDLEn:** Receiver status
 0: Data reception is in progress (Data being received)
 1: No data reception is in progress (Receiver is idle)
 The RIDLEn flag is the receiver status flag. When this read only flag is “0”, it indicates that the receiver is between the initial detection of the start bit and the completion of the stop bit. When the flag is “1”, it indicates that the receiver is idle. Between the completion of the stop bit and the detection of the next start bit, the RIDLEn bit is “1” indicating that the UARTn receiver is idle and the RXn pin stays in logic high condition.

- Bit 2** **RXIFn:** Receive TXR_RXRn data register status
 0: TXR_RXRn data register is empty
 1: TXR_RXRn data register has available data
 The RXIFn flag is the receive data register status flag. When this read only flag is “0”, it indicates that the TXR_RXRn read data register is empty. When the flag is “1”, it indicates that the TXR_RXRn read data register contains new data. When the contents of the shift register are transferred to the TXR_RXRn register, an interrupt is generated if RIEn=1 in the UnCR2 register. If one or more errors are detected in the received word, the appropriate receive-related flags NF_n, FERR_n, and/or PERR_n are set within the same clock cycle. The RXIFn flag will eventually be cleared when the UnSR register is read with RXIFn set, followed by a read from the TXR_RXR register, and if the TXR_RXR register has no more new data available.
- Bit 1** **TIDLEn:** Transmission idle
 0: Data transmission is in progress (Data being transmitted)
 1: No data transmission is in progress (Transmitter is idle)
 The TIDLEn flag is known as the transmission complete flag. When this read only flag is “0”, it indicates that a transmission is in progress. This flag will be set high when the TXIFn flag is “1” and when there is no transmit data or break character being transmitted. When TIDLEn is equal to “1”, the TX_n pin becomes idle with the pin state in logic high condition. The TIDLEn flag is cleared by reading the UnSR register with TIDLEn set and then writing to the TXR_RXRn register. The flag is not generated when a data character or a break is queued and ready to be sent.
- Bit 0** **TXIFn:** Transmit TXR_RXRn data register status
 0: Character is not transferred to the transmit shift register
 1: Character has transferred to the transmit shift register (TXR_RXRn data register is empty)
 The TXIFn flag is the transmit data register empty flag. When this read only flag is “0”, it indicates that the character is not transferred to the transmitter shift register. When the flag is “1”, it indicates that the transmitter shift register has received a character from the TXR_RXRn data register. The TXIFn flag is cleared by reading the UARTn status register (UnSR) with TXIFn set and then writing to the TXR_RXRn data register. Note that when the TXENn bit is set, the TXIFn flag bit will also be set since the transmit data register is not yet full.

• **UnCR1 Register**

The UnCR1 register together with the UnCR2 register are the two UARTn control registers that are used to set the various options for the UARTn function, such as overall on/off control, parity control, data transfer bit length etc. Further explanation on each of the bits is given below:

Bit	7	6	5	4	3	2	1	0
Name	UARTEN _n	BNO _n	PREN _n	PRT _n	STOPS _n	TXBRK _n	RX8 _n	TX8 _n
R/W	R/W	R/W	R/W	R/W	R/W	R/W	R	W
POR	0	0	0	0	0	0	x	0

“x”: unknown

- Bit 7** **UARTENn:** UARTn function enable control
 0: Disable UARTn. TX_n and RX_n pins are in a floating state
 1: Enable UARTn. TX_n and RX_n pins function as UARTn pins
 The UARTENn bit is the UARTn enable bit. When this bit is equal to “0”, the UARTn will be disabled and the RX_n pin as well as the TX_n pin will be in a floating state. When the bit is equal to “1”, the UARTn will be enabled and the TX_n and RX_n pins will function as defined by the TXENn and RXENn enable control bits.

When the UARTn is disabled, it will empty the buffer so any character remaining in the buffer will be discarded. In addition, the value of the baud rate counter will be reset. If the UARTn is disabled, all error and status flags will be reset. Also the TXENn, RXENn, TXBRKn, RXIFn, OERRn, FERRn, PERRn and NFn bits will be cleared, while the TIDLEn, TXIFn and RIDLEn bits will be set. Other control bits in UnCR1, UnCR2 and BRGn registers will remain unaffected. If the UARTn is active and the UARTENn bit is cleared, all pending transmissions and receptions will be terminated and the module will be reset as defined above. When the UARTn is re-enabled, it will restart in the same configuration.

- Bit 6 **BNO**n: Number of data transfer bits selection
0: 8-bit data transfer
1: 9-bit data transfer
This bit is used to select the data length format, which can have a choice of either 8-bit or 9-bit format. When this bit is equal to “1”, a 9-bit data length format will be selected. If the bit is equal to “0”, then an 8-bit data length format will be selected. If 9-bit data length format is selected, then bits RX8n and TX8n will be used to store the 9th bit of the received and transmitted data respectively.
- Bit 5 **PRE**Nn: Parity function enable control
0: Parity function is disabled
1: Parity function is enabled
This is the parity enable bit. When this bit is equal to “1”, the parity function will be enabled. If the bit is equal to “0”, then the parity function will be disabled.
- Bit 4 **PRT**n: Parity type selection bit
0: Even parity for parity generator
1: Odd parity for parity generator
This bit is the parity type selection bit. When this bit is equal to “1”, odd parity type will be selected. If the bit is equal to “0”, then even parity type will be selected.
- Bit 3 **STOPS**n: Number of Stop bits selection
0: One stop bit format is used
1: Two stop bits format is used
This bit determines if one or two stop bits are to be used. When this bit is equal to “1”, two stop bits are used. If this bit is equal to “0”, then only one stop bit is used.
- Bit 2 **TXBRK**n: Transmit break character
0: No break character is transmitted
1: Break characters transmit
The TXBRKn bit is the Transmit Break Character bit. When this bit is “0”, there are no break characters and the TXn pin operates normally. When the bit is “1”, there are transmit break characters and the transmitter will send logic zeros. When this bit is equal to “1”, after the buffered data has been transmitted, the transmitter output is held low for a minimum of a 13-bit length and until the TXBRKn bit is reset.
- Bit 1 **RX8**n: Receive data bit 8 for 9-bit data transfer format (read only)
This bit is only used if 9-bit data transfers are used, in which case this bit location will store the 9th bit of the received data known as RX8n. The BNO n bit is used to determine whether data transfers are in 8-bit or 9-bit format.
- Bit 0 **TX8**n: Transmit data bit 8 for 9-bit data transfer format (write only)
This bit is only used if 9-bit data transfers are used, in which case this bit location will store the 9th bit of the transmitted data known as TX8n. The BNO n bit is used to determine whether data transfers are in 8-bit or 9-bit format.

• **UnCR2 Register**

The UnCR2 register is the second of the two UARTn control registers and serves several purposes. One of its main functions is to control the basic enable/disable operation of the UARTn Transmitter and Receiver as well as enabling the various UARTn interrupt sources. The register also serves to control the baud rate speed, receiver wake-up enable and the address detect enable. Further explanation on each of the bits is given below:

Bit	7	6	5	4	3	2	1	0
Name	TXENn	RXENn	BRGHn	ADDENn	WAKEn	RIEn	TIIEEn	TEIEEn
R/W	R/W	R/W	R/W	R/W	R/W	R/W	R/W	R/W
POR	0	0	0	0	0	0	0	0

Bit 7 **TXENn**: UARTn Transmitter enabled control

- 0: UARTn transmitter is disabled
- 1: UARTn transmitter is enabled

The bit named TXENn is the Transmitter Enable Bit. When this bit is equal to “0”, the transmitter will be disabled with any pending data transmissions being aborted. In addition the buffers will be reset. In this situation the TXn pin will be in a floating state.

If the TXENn bit is equal to “1” and the UARTEEn bit is also equal to “1”, the transmitter will be enabled and the TXn pin will be controlled by the UARTn. Clearing the TXENn bit during a transmission will cause the data transmission to be aborted and will reset the transmitter. If this situation occurs, the TXn pin will be in a floating state.

Bit 6 **RXENn**: UARTn Receiver enabled control

- 0: UARTn receiver is disabled
- 1: UARTn receiver is enabled

The bit named RXENn is the Receiver Enable Bit. When this bit is equal to “0”, the receiver will be disabled with any pending data receptions being aborted. In addition the receive buffers will be reset. In this situation the RXn pin will be in a floating state. If the RXENn bit is equal to “1” and the UARTEEn bit is also equal to “1”, the receiver will be enabled and the RXn pin will be controlled by the UARTn. Clearing the RXENn bit during a reception will cause the data reception to be aborted and will reset the receiver. If this situation occurs, the RXn pin will be in a floating state.

Bit 5 **BRGHn**: Baud Rate speed selection

- 0: Low speed baud rate
- 1: High speed baud rate

The bit named BRGHn selects the high or low speed mode of the Baud Rate Generator. This bit, together with the value placed in the baud rate register BRGn, controls the Baud Rate of the UARTn. If this bit is equal to “1”, the high speed mode is selected. If the bit is equal to “0”, the low speed mode is selected.

Bit 4 **ADDENn**: Address detect function enable control

- 0: Address detect function is disabled
- 1: Address detect function is enabled

The bit named ADDENn is the address detect function enable control bit. When this bit is equal to “1”, the address detect function is enabled. When it occurs, if the 8th bit, which corresponds to RX7n if BNO=0 or the 9th bit, which corresponds to RX8n if BNO=1, has a value of “1”, then the received word will be identified as an address, rather than data. If the corresponding interrupt is enabled, an interrupt request will be generated each time the received word has the address bit set, which is the 8th or 9th bit depending on the value of BNO. If the address bit known as the 8th or 9th bit of the received word is “0” with the address detect function being enabled, an interrupt will not be generated and the received data will be discarded.

- Bit 3 **WAKEn**: RXn pin wake-up UARTn function enable control
 0: RXn pin wake-up UARTn function is disabled
 1: RXn pin wake-up UARTn function is enabled
 This bit is used to control the wake-up UARTn function when a falling edge on the RXn pin occurs. Note that this bit is only available when the UARTn clock (f_{H1}) is switched off. There will be no RXn pin wake-up UARTn function if the UARTn clock (f_{H1}) exists. If the WAKEn bit is set to 1 as the UARTn clock (f_{H1}) is switched off, a UARTn wake-up request will be initiated when a falling edge on the RXn pin occurs. When this request happens and the corresponding interrupt is enabled, an RXn pin wake-up UARTn interrupt will be generated to inform the MCU to wake up the UARTn function by switching on the UARTn clock (f_{H1}) via the application program. Otherwise, the UARTn function cannot resume even if there is a falling edge on the RXn pin when the WAKEn bit is cleared to 0.
- Bit 2 **RIEn**: Receiver interrupt enable control
 0: Receiver related interrupt is disabled
 1: Receiver related interrupt is enabled
 This bit enables or disables the receiver interrupt. If this bit is equal to “1” and when the receiver overrun flag OERRn or receive data available flag RXIFn is set, the UARTn interrupt request flag will be set. If this bit is equal to “0”, the UARTn interrupt request flag will not be influenced by the condition of the OERRn or RXIFn flags.
- Bit 1 **TIEn**: Transmitter Idle interrupt enable control
 0: Transmitter idle interrupt is disabled
 1: Transmitter idle interrupt is enabled
 This bit enables or disables the transmitter idle interrupt. If this bit is equal to “1” and when the transmitter idle flag TIDLEn is set, due to a transmitter idle condition, the UARTn interrupt request flag will be set. If this bit is equal to “0”, the UARTn interrupt request flag will not be influenced by the condition of the TIDLEn flag.
- Bit 0 **TEIEn**: Transmitter Empty interrupt enable control
 0: Transmitter empty interrupt is disabled
 1: Transmitter empty interrupt is enabled
 This bit enables or disables the transmitter empty interrupt. If this bit is equal to “1” and when the transmitter empty flag TXIFn is set, due to a transmitter empty condition, the UARTn interrupt request flag will be set. If this bit is equal to “0”, the UARTn interrupt request flag will not be influenced by the condition of the TXIFn flag.

• **TXR_RXRn Register**

The TXR_RXRn register is the data register which is used to store the data to be transmitted on the TXn pin or being received from the RXn pin.

Bit	7	6	5	4	3	2	1	0
Name	TXRXn7	TXRXn6	TXRXn5	TXRXn4	TXRXn3	TXRXn2	TXRXn1	TXRXn0
R/W	R/W	R/W	R/W	R/W	R/W	R/W	R/W	R/W
POR	x	x	x	x	x	x	x	x

“x”: unknown

- Bit 7~0 **TXRXn7~TXRXn0**: UARTn Transmit/Receive Data bit 7 ~ bit 0

• **BRGn Register**

Bit	7	6	5	4	3	2	1	0
Name	BRGn7	BRGn6	BRGn5	BRGn4	BRGn3	BRGn2	BRGn1	BRGn0
R/W	R/W	R/W	R/W	R/W	R/W	R/W	R/W	R/W
POR	x	x	x	x	x	x	x	x

“x”: unknown

Bit 7~0 **BRGn7~BRGn0**: Baud Rate values

By programming the BRGHn bit in UnCR2 Register which allows selection of the related formula described above and programming the required value in the BRGn register, the required baud rate can be setup.

Note: Baud rate= $f_{H}/[64 \times (N+1)]$ if BRGHn=0.

Baud rate= $f_{H}/[16 \times (N+1)]$ if BRGHn=1.

Baud Rate Generator

To setup the speed of the serial data communication, the UARTn function contains its own dedicated baud rate generator. The baud rate is controlled by its own internal free running 8-bit timer, the period of which is determined by two factors. The first of these is the value placed in the baud rate register BRGn and the second is the value of the BRGHn bit with the control register UnCR2. The BRGHn bit decides if the baud rate generator is to be used in a high speed mode or low speed mode, which in turn determines the formula that is used to calculate the baud rate. The value N in the BRGn register which is used in the following baud rate calculation formula determines the division factor. Note that N is the decimal value placed in the BRGn register and has a range of between 0 and 255.

UnCR2 BRGHn Bit	0	1
Baud Rate (BR)	$f_{H}/[64 (N+1)]$	$f_{H}/[16 (N+1)]$

By programming the BRGHn bit which allows selection of the related formula and programming the required value in the BRGn register, the required baud rate can be setup. Note that because the actual baud rate is determined using a discrete value, N, placed in the BRGn register, there will be an error associated between the actual and requested value. The following example shows how the BRGn register value N and the error value can be calculated.

Calculating the Baud Rate and Error Values

For a clock frequency of 4MHz, and with BRGHn cleared to zero determine the BRGn register value N, the actual baud rate and the error value for a desired baud rate of 4800.

From the above table the desired baud rate $BR=f_{H}/[64 (N+1)]$

Re-arranging this equation gives $N=[f_{H}/(BR \times 64)] - 1$

Giving a value for $N=[4000000/(4800 \times 64)] - 1=12.0208$

To obtain the closest value, a decimal value of 12 should be placed into the BRGn register. This gives an actual or calculated baud rate value of $BR=4000000/[64 \times (12+1)]=4808$

Therefore the error is equal to $(4808 - 4800)/4800=0.16\%$

UARTn Setup and Control

For data transfer, the UARTn function utilizes a non-return-to-zero, more commonly known as NRZ, format. This is composed of one start bit, eight or nine data bits, and one or two stop bits. Parity is supported by the UARTn hardware, and can be setup to be even, odd or no parity. For the most common data format, 8 data bits along with no parity and one stop bit, denoted as 8, N, 1, is used as the default setting, which is the setting at power-on. The number of data bits and stop bits, along with the parity, are setup by programming the corresponding BNO_n, PRT_n, PREN_n, and STOPS_n

bits in the UnCR1 register. The baud rate used to transmit and receive data is setup using the internal 8-bit baud rate generator, while the data is transmitted and received LSB first. Although the UARTn transmitter and receiver are functionally independent, they both use the same data format and baud rate. In all cases stop bits will be used for data transmission.

Enabling/Disabling the UARTn Interface

The basic on/off function of the internal UARTn function is controlled using the UARTENn bit in the UnCR1 register. If the UARTENn, TXENn and RXENn bits are set, then these two UARTn pins will act as normal TXn output pin and RXn input pin respectively. If no data is being transmitted on the TXn pin, then it will default to a logic high value.

Clearing the UARTENn bit will disable the TXn and RXn pins and allow these two pins to be in a floating state. When the UARTn function is disabled the buffer will be reset to an empty condition, at the same time discarding any remaining residual data. Disabling the UARTn will also reset the error and status flags with bits TXENn, RXENn, TXBRKn, RXIFn, OERRn, FERRn, PERRn and NFn being cleared while bits TIDLEn, TXIFn and RIDLEn will be set. The remaining control bits in the UnCR1, UnCR2 and BRGn registers will remain unaffected. If the UARTENn bit in the UnCR1 register is cleared while the UARTn is active, then all pending transmissions and receptions will be immediately suspended and the UARTn will be reset to a condition as defined above. If the UARTn is then subsequently re-enabled, it will restart again in the same configuration.

Data, Parity and Stop Bit Selection

The format of the data to be transferred is composed of various factors such as data bit length, parity on/off, parity type, address bits and the number of stop bits. These factors are determined by the setup of various bits within the UnCR1 register. The BNO n bit controls the number of data bits which can be set to either 8 or 9, the PRTn bit controls the choice of odd or even parity, the PRENn bit controls the parity on/off function and the STOPSn bit decides whether one or two stop bits are to be used. The following table shows various formats for data transmission. The address bit, which is the MSB of the data byte, identifies the frame as an address character or data if the address detect function is enabled. The number of stop bits, which can be either one or two, is independent of the data length and is only used for the transmitter. There is only one stop bit for the receiver.

Start Bit	Data Bits	Address Bit	Parity Bit	Stop Bit
Example of 8-bit Data Formats				
1	8	0	0	1
1	7	0	1	1
1	7	1	0	1
Example of 9-bit Data Formats				
1	9	0	0	1
1	8	0	1	1
1	8	1	0	1

Transmitter Receiver Data Format

The following diagram shows the transmit and receive waveforms for both 8-bit and 9-bit data formats.

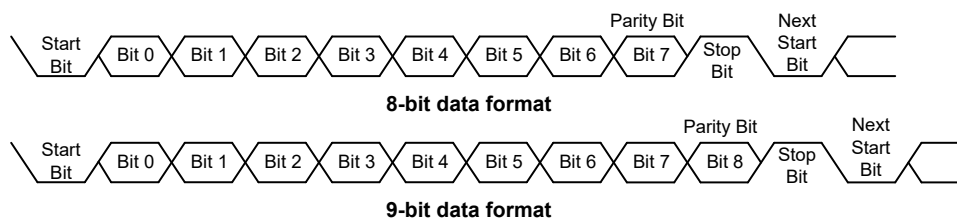

UARTn Transmitter

Data word lengths of either 8 or 9 bits can be selected by programming the BNO_n bit in the UnCR1 register. When BNO_n bit is set, the word length will be set to 9 bits. In this case the 9th bit, which is the MSB, needs to be stored in the TX8_n bit in the UnCR1 register. At the transmitter core lies the Transmitter Shift Register, more commonly known as the TSR_n, whose data is obtained from the transmit data register, which is known as the TXR_RXR_n register. The data to be transmitted is loaded into this TXR_RXR_n register by the application program. The TSR_n register is not written to with new data until the stop bit from the previous transmission has been sent out. As soon as this stop bit has been transmitted, the TSR_n can then be loaded with new data from the TXR_RXR_n register, if it is available. It should be noted that the TSR_n register, unlike many other registers, is not directly mapped into the Data Memory area and as such is not available to the application program for direct read/write operations. An actual transmission of data will normally be enabled when the TXEN_n bit is set, but the data will not be transmitted until the TXR_RXR_n register has been loaded with data and the baud rate generator has defined a shift clock source. However, the transmission can also be initiated by first loading data into the TXR_RXR_n register, after which the TXEN_n bit can be set. When a transmission of data begins, the TSR_n is normally empty, in which case a transfer to the TXR_RXR_n register will result in an immediate transfer to the TSR_n. If during a transmission the TXEN_n bit is cleared, the transmission will immediately cease and the transmitter will be reset. The TX_n output pin can then be in a floating state.

Transmitting Data

When the UART_n is transmitting data, the data is shifted on the TX_n pin from the shift register, with the least significant bit first. In the transmit mode, the TXR_RXR_n register forms a buffer between the internal bus and the transmitter shift register. It should be noted that if 9-bit data format has been selected, then the MSB will be taken from the TX8_n bit in the UnCR1 register. The steps to initiate a data transfer can be summarized as follows:

- Make the correct selection of the BNO_n, PRT_n, PREN_n and STOPS_n bits to define the required word length, parity type and number of stop bits.
- Setup the BRG_n register to select the desired baud rate.
- Set the TXEN_n bit to ensure that the TX_n pin is used as a UART_n transmitter pin.
- Access the UnSR register and write the data that is to be transmitted into the TXR_RXR_n register. Note that this step will clear the TXIF_n bit.

This sequence of events can now be repeated to send additional data.

It should be noted that when TXIF_n=0, data will be inhibited from being written to the TXR_RXR_n register. Clearing the TXIF_n flag is always achieved using the following software sequence:

1. A UnSR register access
2. A TXR_RXR_n register write execution

The read-only TXIF_n flag is set by the UART_n hardware and if set indicates that the TXR_RXR_n register is empty and that other data can now be written into the TXR_RXR_n register without overwriting the previous data. If the TEIEN bit is set then the TXIF_n flag will generate an interrupt.

During a data transmission, a write instruction to the TXR_RXR_n register will place the data into the TXR_RXR_n register, which will be copied to the shift register at the end of the present transmission. When there is no data transmission in progress, a write instruction to the TXR_RXR_n register will place the data directly into the shift register, resulting in the commencement of data transmission, and the TXIF_n bit being immediately set. When a frame transmission is complete, which happens after stop bits are sent or after the break frame, the TIDLEN bit will be set. To clear the TIDLEN bit the following software sequence is used:

1. A UnSR register access
2. A TXR_RXRn register write execution

Note that both the TXIFn and TIDLEn bits are cleared by the same software sequence.

Transmit Break

If the TXBRK_n bit is set and the state keeps for a time greater than $[(BRG_{n+1}) \times t_{th}]$ while TIDL_n=1 then break characters will be sent on the next transmission. Break character transmission consists of a start bit, followed by $13 \times N$ '0' bits and stop bits, where $N=1, 2, \text{etc.}$ If a break character is to be transmitted then the TXBRK_n bit must be first set by the application program, and then cleared to generate the stop bits. Transmitting a break character will not generate a transmit interrupt. Note that a break condition length is at least 13 bits long. If the TXBRK_n bit is continually kept at a logic high level then the transmitter circuitry will transmit continuous break characters. After the application program has cleared the TXBRK_n bit, the transmitter will finish transmitting the last break character and subsequently send out one or two stop bits. The automatic logic highs at the end of the last break character will ensure that the start bit of the next frame is recognized.

UARTn Receiver

The UART_n is capable of receiving word lengths of either 8 or 9 bits. If the BN_{On} bit is set, the word length will be set to 9 bits with the MSB being stored in the RX8_n bit of the UnCR1 register. At the receiver core lies the Receive Serial Shift Register, commonly known as the RSR_n. The data which is received on the RX_n external input pin is sent to the data recovery block. The data recovery block operating speed is 16 times that of the baud rate, while the main receive serial shifter operates at the baud rate. After the RX_n pin is sampled for the stop bit, the received data in RSR_n is transferred to the receive data register, if the register is empty. The data which is received on the external RX_n input pin is sampled three times by a majority detect circuit to determine the logic level that has been placed onto the RX_n pin. It should be noted that the RSR_n register, unlike many other registers, is not directly mapped into the Data Memory area and as such is not available to the application program for direct read/write operations.

Receiving Data

When the UART_n receiver is receiving data, the data is serially shifted in on the external RX_n input pin, LSB first. In the read mode, the TXR_RXR_n register forms a buffer between the internal bus and the receiver shift register. The TXR_RXR_n register is a two byte deep FIFO data buffer, where two bytes can be held in the FIFO while a third byte can continue to be received. Note that the application program must ensure that the data is read from TXR_RXR_n before the third byte has been completely shifted in, otherwise this third byte will be discarded and an overrun error OERR_n will be subsequently indicated. The steps to initiate a data transfer can be summarized as follows:

- Make the correct selection of BN_{On}, PRT_n and PREN_n bits to define the word length, parity type.
- Setup the BRG_n register to select the desired baud rate.
- Set the RXEN_n bit to ensure that the RX_n pin is used as a UART_n receiver pin.

At this point the receiver will be enabled which will begin to look for a start bit.

When a character is received the following sequence of events will occur:

- The RXIF_n bit in the UnSR register will be set when the TXR_RXR_n register has data available. There will be at most one more character available before an overrun error occurs.
- When the contents of the shift register have been transferred to the TXR_RXR_n register, then if the RIEN bit is set, an interrupt will be generated.
- If during reception, a frame error, noise error, parity error, or an overrun error has been detected, then the error flags can be set.

The RXIFn bit can be cleared using the following software sequence:

1. A UnSR register access
2. A TXR_RXRn register read execution

Receive Break

Any break character received by the UARTn will be managed as a framing error. The receiver will count and expect a certain number of bit times as specified by the values programmed into the BNO_n bit plus one stop bit. If the break is much longer than 13 bit times, the reception will be considered as complete after the number of bit times specified by BNO_n plus one stop bit. The RXIFn bit is set, FERRn is set, zeros are loaded into the receive data register, interrupts are generated if appropriate and the RIDLEn bit is set. A break is regarded as a character that contains only zeros with the FERRn flag set. If a long break signal has been detected, the receiver will regard it as a data frame including a start bit, data bits and the invalid stop bit and the FERRn flag will be set. The receiver must wait for a valid stop bit before looking for the next start bit. The receiver will not make the assumption that the break condition on the line is the next start bit. The break character will be loaded into the buffer and no further data will be received until stop bits are received. It should be noted that the RIDLEn read only flag will go high when the stop bits have not yet been received. The reception of a break character on the UARTn registers will result in the following:

- The framing error flag, FERRn, will be set.
- The receive data register, TXR_RXRn, will be cleared.
- The OERRn, NF_n, PERRn, RIDLEn or RXIFn flags will possibly be set.

Idle Status

When the receiver is reading data, which means it will be in between the detection of a start bit and the reading of a stop bit, the receiver status flag in the UnSR register, otherwise known as the RIDLEn flag, will have a zero value. In between the reception of a stop bit and the detection of the next start bit, the RIDLEn flag will have a high value, which indicates the receiver is in an idle condition.

Receiver Interrupt

The read only receive interrupt flag RXIFn in the UnSR register is set by an edge generated by the receiver. An interrupt is generated if RIEn=1, when a word is transferred from the Receive Shift Register, RSRn, to the Receive Data Register, TXR_RXRn. An overrun error can also generate an interrupt if RIEn=1.

Managing Receiver Errors

Several types of reception errors can occur within the UARTn module, the following section describes the various types and how they are managed by the UARTn.

Overrun Error – OERRn

The TXR_RXRn register is composed of a two byte deep FIFO data buffer, where two bytes can be held in the FIFO register, while a third byte can continue to be received. Before this third byte has been entirely shifted in, the data should be read from the TXR_RXRn register. If this is not done, the overrun error flag OERRn will be consequently indicated.

In the event of an overrun error occurring, the following will happen:

- The OERRn flag in the UnSR register will be set.
- The TXR_RXRn contents will not be lost.
- The shift register will be overwritten.
- An interrupt will be generated if the RIEn bit is set.

The OERRn flag can be cleared by an access to the UnSR register followed by a read to the TXR_RXRn register.

Noise Error – NF_n

Over-sampling is used for data recovery to identify valid incoming data and noise. If noise is detected within a frame the following will occur:

- The read only noise flag, NF_n, in the UnSR register will be set on the rising edge of the RXIF_n bit.
- Data will be transferred from the Shift register to the TXR_RXR_n register.
- No interrupt will be generated. However this bit rises at the same time as the RXIF_n bit which itself generates an interrupt.

Note that the NF_n flag is reset by an UnSR register read operation followed by a TXR_RXR_n register read operation.

Framing Error – FERR_n

The read only framing error flag, FERR_n, in the UnSR register, is set if a zero is detected instead of stop bits. If two stop bits are selected, both stop bits must be high; otherwise the FERR_n flag will be set. The FERR_n flag and the received data will be recorded in the UnSR and TXR_RXR_n registers respectively, and the flag is cleared in any reset.

Parity Error – PERR_n

The read only parity error flag, PERR_n, in the UnSR register, is set if the parity of the received word is incorrect. This error flag is only applicable if the parity is enabled, PREN_n=1, and if the parity type, odd or even is selected. The read only PERR_n flag and the received data will be recorded in the UnSR and TXR_RXR_n registers respectively. It is cleared on any reset, it should be noted that the flags, FERR_n and PERR_n, in the UnSR register should first be read by the application program before reading the data word.

UART_n Interrupt Structure

Several individual UART_n conditions can generate a UART_n interrupt. When these conditions exist, a low pulse will be generated to get the attention of the microcontroller. These conditions are a transmitter data register empty, transmitter idle, receiver data available, receiver overrun, address detect and an RX_n pin wake-up. When any of these conditions are created, if the global interrupt enable bit and its corresponding interrupt control bit are enabled and the stack is not full, the program will jump to its corresponding interrupt vector where it can be serviced before returning to the main program. Four of these conditions have the corresponding UnSR register flags which will generate a UART_n interrupt if its associated interrupt enable control bit in the UnCR2 register is set. The two transmitter interrupt conditions have their own corresponding enable control bits, while the two receiver interrupt conditions have a shared enable control bit. These enable bits can be used to mask out individual UART_n interrupt sources.

The address detect condition, which is also a UART_n interrupt source, does not have an associated flag, but will generate a UART_n interrupt when an address detect condition occurs if its function is enabled by setting the ADDEN_n bit in the UnCR2 register. An RX_n pin wake-up, which is also a UART_n interrupt source, does not have an associated flag, but will generate a UART_n interrupt if the UART_n clock (f_{H}) source is switched off and the WAKEN and RIEN bits in the UnCR2 register are set when a falling edge on the RX_n pin occurs.

Note that the UnSR register flags are read only and cannot be cleared or set by the application program, neither will they be cleared when the program jumps to the corresponding interrupt servicing routine, as is the case for some of the other interrupts. The flags will be cleared automatically when certain actions are taken by the UART_n, the details of which are given in the UART_n register section. The overall UART_n interrupt can be disabled or enabled by the related interrupt enable control bits in the interrupt control registers of the microcontroller to decide whether the interrupt requested by the UART_n module is masked out or allowed.

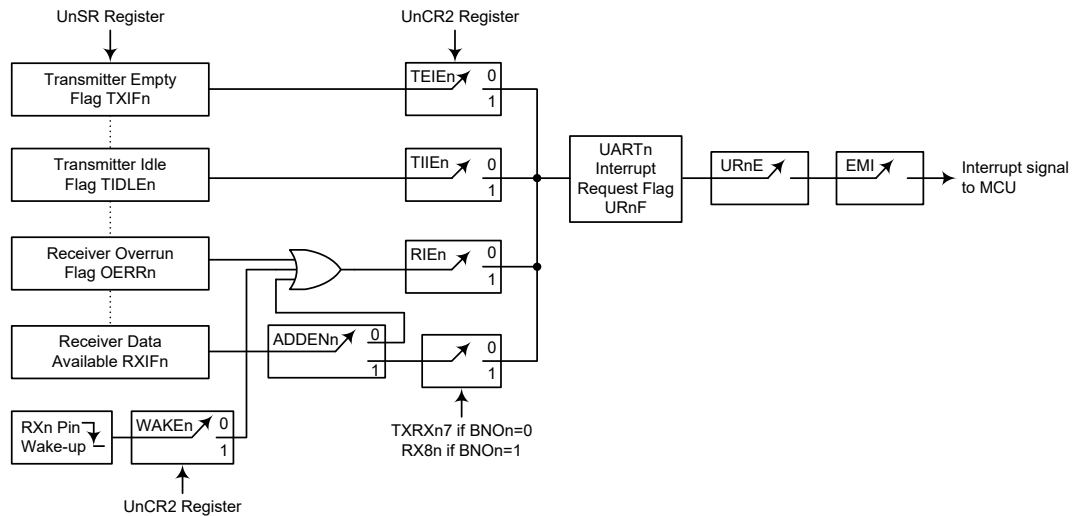

UARTn Interrupt Structure (n=0~1)

Address Detect Mode

Setting the Address Detect Mode bit, ADDENn, in the UnCR2 register, enables this special mode. If this bit is enabled then an additional qualifier will be placed on the generation of a Receiver Data Available interrupt, which is requested by the RXIFn flag. If the ADDENn bit is enabled, then when data is available, an interrupt will only be generated, if the highest received bit has a high value. Note that the URnE and EMI interrupt enable bits must also be enabled for correct interrupt generation. This highest address bit is the 9th bit if BNO=1 or the 8th bit if BNO=0. If this bit is high, then the received word will be defined as an address rather than data. A Data Available interrupt will be generated every time the last bit of the received word is set. If the ADDENn bit is not enabled, then a Receiver Data Available interrupt will be generated each time the RXIFn flag is set, irrespective of the data last bit status. The address detect mode and parity enable are mutually exclusive functions. Therefore if the address detect mode is enabled, then to ensure correct operation, the parity function should be disabled by resetting the parity enable bit PRENN to zero.

ADDENn	9th Bit if BNO=1 8th Bit if BNO=0	UARTn Interrupt Generated
0	0	√
	1	√
1	0	×
	1	√

ADDENn Bit Function

UARTn Power Down and Wake-up

When the UARTn clock (f_H) is off, the UARTn will cease to function, and all clock sources to the module are shutdown. If the UARTn clock (f_H) is off while a transmission is still in progress, then the transmission will be paused until the UARTn clock source derived from the microcontroller is activated. In a similar way, if the MCU enters the IDLE or SLEEP Mode while receiving data, then the reception of data will likewise be paused. When the MCU enters the IDLE or SLEEP Mode, note that the UnSR, UnCR1, UnCR2, TXR_RXRn, as well as the BRGn register will not be affected. It is recommended to make sure first that the UARTn data transmission or reception has been finished before the microcontroller enters the IDLE or SLEEP mode.

The UARTn function contains a receiver RXn pin wake-up function, which is enabled or disabled by the WAKEn bit in the UnCR2 register. If this bit, along with the UARTn enable bit, UARTENn, the receiver enable bit, RXENn and the receiver interrupt bit, RIEn, are all set when the UARTn clock (f_{HI}) is off, then a falling edge on the RXn pin will trigger an RXn pin wake-up UARTn interrupt. Note that as it takes certain system clock cycles after a wake-up, before normal microcontroller operation resumes, any data received during this time on the RXn pin will be ignored.

For a UARTn wake-up interrupt to occur, in addition to the bits for the wake-up being set, the global interrupt enable bit, EMI, and the UARTn interrupt enable bit, URnE, must be set. If the EMI and URnE bits are not set then only a wake up event will occur and no interrupt will be generated. Note also that as it takes certain system clock cycles after a wake-up before normal microcontroller resumes, the UARTn interrupt will not be generated until after this time has elapsed.

Low Voltage Detector – LVD

Each device has a Low Voltage Detector function, also known as LVD. This enabled the device to monitor the power supply voltage, V_{DD}, and provide a warning signal should it fall below a certain level. This function may be especially useful in battery applications where the supply voltage will gradually reduce as the battery ages, as it allows an early warning battery low signal to be generated. The Low Voltage Detector also has the capability of generating an interrupt signal.

LVD Register

The Low Voltage Detector function is controlled using a single register with the name LVDC. Three bits in this register, VLVD2~VLVD0, are used to select one of eight fixed voltages below which a low voltage condition will be determined. A low voltage condition is indicated when the LVDO bit is set. If the LVDO bit is low, this indicates that the V_{DD} voltage is above the preset low voltage value. The LVDEN bit is used to control the overall on/off function of the low voltage detector. Setting the bit high will enable the low voltage detector. Clearing the bit to zero will switch off the internal low voltage detector circuits. As the low voltage detector will consume a certain amount of power, it may be desirable to switch off the circuit when not in use, an important consideration in power sensitive battery powered applications.

• LVDC Register

Bit	7	6	5	4	3	2	1	0
Name	—	—	LVDO	LVDEN	VBGEN	VLVD2	VLVD1	VLVD0
R/W	—	—	R	R/W	R/W	R/W	R/W	R/W
POR	—	—	0	0	0	0	0	0

Bit 7~6 Unimplemented, read as “0”

Bit 5 **LVDO**: LVD Output Flag
 0: No Low Voltage Detect
 1: Low Voltage Detect

Bit 4 **LVDEN**: Low Voltage Detector Control
 0: Disable
 1: Enable

Bit 3 **VBGEN**: Bandgap Buffer Control
 0: Disable
 1: Enable

Note that the Bandgap circuit is enabled when the LVD or LVR function is enabled or when the VBGEN bit is set to 1.

Bit 2~0	VLVD2~VLVD0: Select LVD Voltage
	000: 2.0V
	001: 2.2V
	010: 2.4V
	011: 2.7V
	100: 3.0V
	101: 3.3V
	110: 3.6V
	111: 4.0V

LVD Operation

The Low Voltage Detector function operates by comparing the power supply voltage, V_{DD} , with a pre-specified voltage level stored in the LVDC register. This has a range of between 2.0V and 4.0V. When the power supply voltage, V_{DD} , falls below this pre-determined value, the LVDO bit will be set high indicating a low power supply voltage condition. When the device is in the SLEEP mode, the low voltage detector will be disabled even if the LVDEN bit is high. After enabling the Low Voltage Detector, a time delay t_{LVDS} should be allowed for the circuitry to stabilise before reading the LVDO bit. Note also that as the V_{DD} voltage may rise and fall rather slowly, at the voltage nears that of V_{LVD} , there may be multiple bit LVDO transitions.

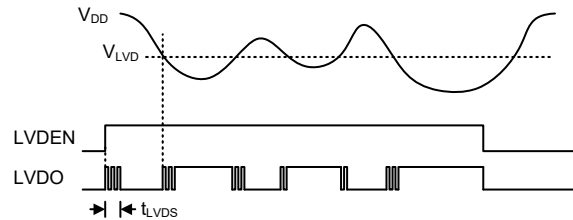

LVD Operation

The Low Voltage Detector also has its own interrupt, providing an alternative means of low voltage detection, in addition to polling the LVDO bit. The interrupt will only be generated after a delay of t_{LVD} after the LVDO bit has been set high by a low voltage condition. When the device is powered down the Low Voltage Detector will remain active if the LVDEN bit is high. In this case, the LVF interrupt request flag will be set, causing an interrupt to be generated if V_{DD} falls below the preset LVD voltage. This will cause the device to wake-up from the IDLE Mode, however if the Low Voltage Detector wake up function is not required then the LVF flag should be first set high before the device enters the IDLE Mode.

Interrupts

Interrupts are an important part of any microcontroller system. When an external event or an internal function such as a Timer Module or an A/D converter requires microcontroller attention, their corresponding interrupt will enforce a temporary suspension of the main program allowing the microcontroller to direct attention to their respective needs. These devices contain an external interrupt and several internal interrupt functions. The external interrupt is generated by the action of the external INT pin, while the internal interrupts are generated by various internal functions such as the TMs, Time Base, LVD, EEPROM, UART and the A/D converter, etc.

The various interrupt enable bits, together with their associated request flags, are shown in the accompanying diagrams with their order of priority. Some interrupt sources have their own individual vector while others share the same multi-function interrupt vector.

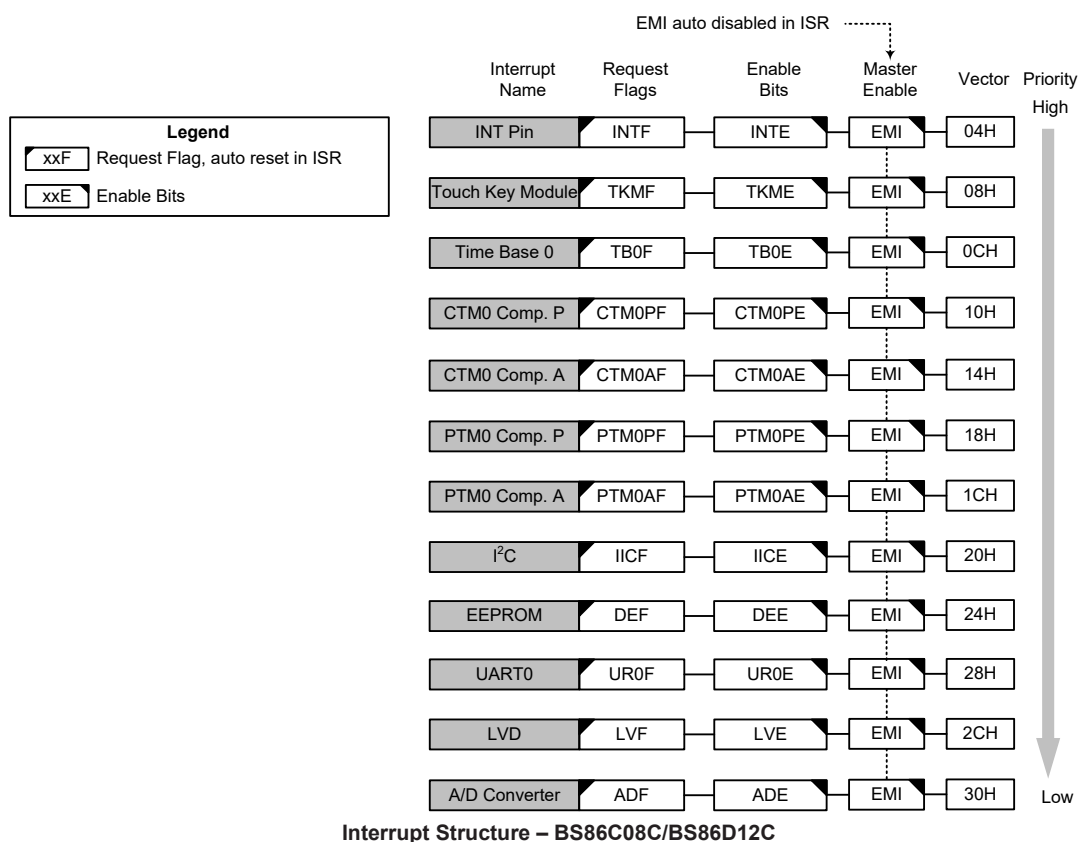

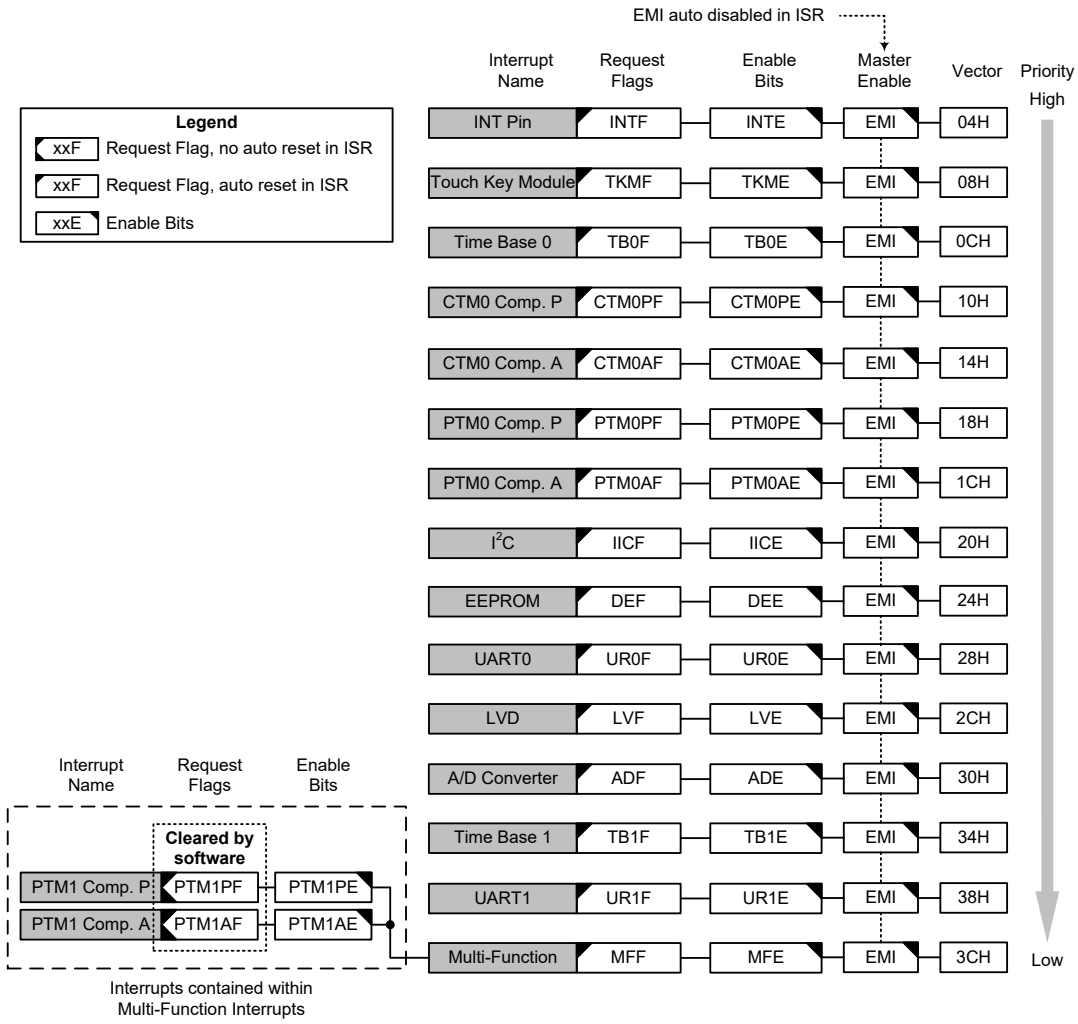

Interrupt Structure – BS86E16C

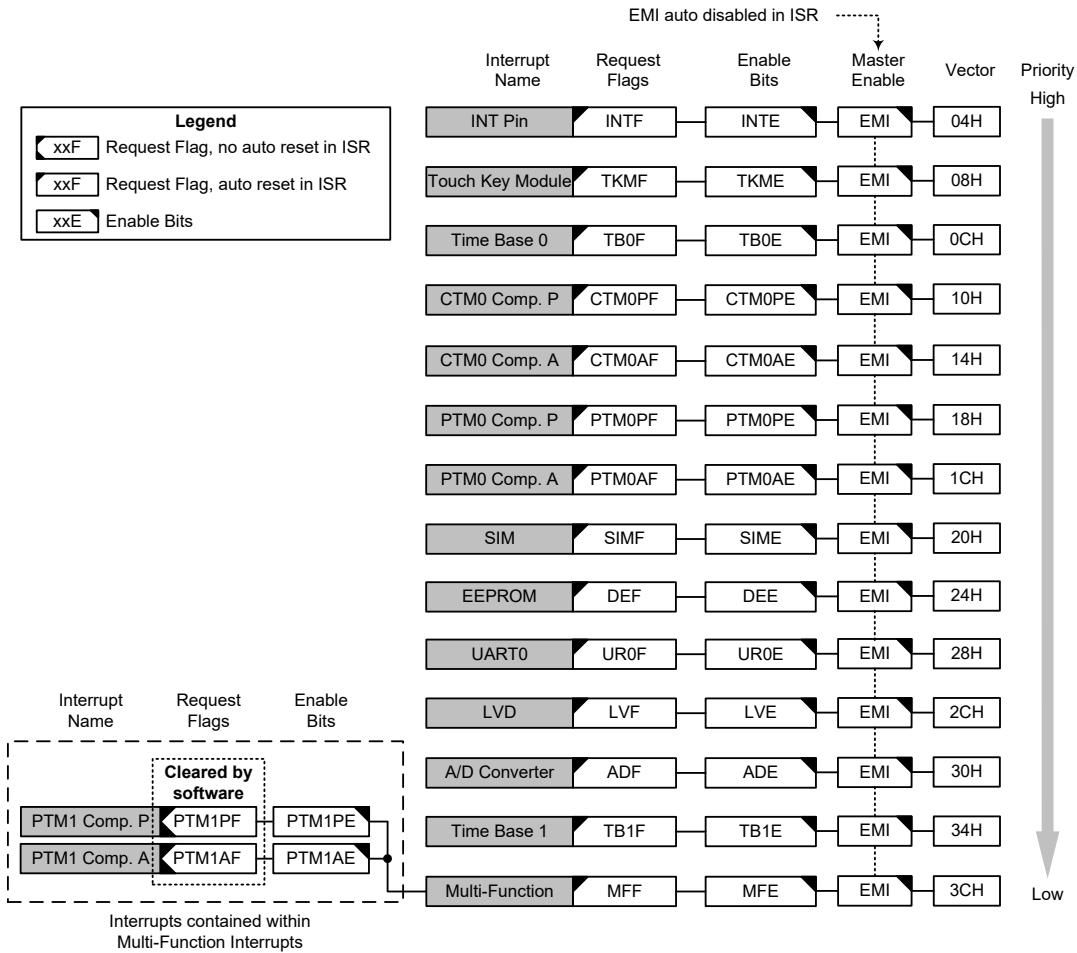

Interrupt Structure – BS86D20C

Interrupt Registers

Overall interrupt control, which basically means the setting of request flags when certain microcontroller conditions occur and the setting of interrupt enable bits by the application program, is controlled by a series of registers, located in the Special Purpose Data Memory, as shown in the accompanying table. The number of registers depends upon the device chosen but fall into three categories. The first is the INTC0~INTC3 registers which setup the primary interrupts. The second is the MFI register which setups the Multi-function interrupt. Finally there is an INTEG register to setup the external interrupt trigger edge type.

Each register contains a number of enable bits to enable or disable individual interrupts as well as interrupt flags to indicate the presence of an interrupt request. The naming convention of these follows a specific pattern. First is listed an abbreviated interrupt type, then the (optional) number of that interrupt followed by either an “E” for enable/disable bit or “F” for request flag.

Function	Enable Bit	Request Flag	Notes
Global	EMI	—	—
INT Pin	INTE	INTF	—
Touch Key Module	TKME	TKMF	—
Time Base	TBnE	TBnF	n=0 for BS86C08C/BS86D12C n=0~1 for BS86E16C/BS86D20C
I ² C	IICE	IICF	For BS86C08C/BS86D12C/BS86E16C
SIM	SIME	SIMF	For BS86D20C
EEPROM write operation	DEE	DEF	—
UART	URnE	URnF	n=0 for BS86C08C/BS86D12C/BS86D20C n=0~1 for BS86E16C
LVD	LVE	LVF	—
A/D Converter	ADE	ADF	—
Multi-function	MFE	MFF	For BS86E16C/BS86D20C
CTM	CTMnPE	CTMnPF	n=0
	CTMnAE	CTMnAF	
PTM	PTMnPE	PTMnPF	n=0 for BS86C08C/BS86D12C n=0~1 for BS86E16C/BS86D20C
	PTMnAE	PTMnAF	

Interrupt Register Bit Naming Conventions

Register Name	Bit							
	7	6	5	4	3	2	1	0
INTEG	—	—	—	—	—	—	INTS1	INTS0
INTC0	—	TB0F	TKMF	INTF	TB0E	TKME	INTE	EMI
INTC1	PTM0AF	PTM0PF	CTM0AF	CTM0PF	PTM0AE	PTM0PE	CTM0AE	CTM0PE
INTC2	LVF	UR0F	DEF	IICF	LVE	UR0E	DEE	IICE
INTC3	—	—	—	ADF	—	—	—	ADE

Interrupt Register List – BS86C08C/BS86D12C

Register Name	Bit							
	7	6	5	4	3	2	1	0
INTEG	—	—	—	—	—	—	INTS1	INTS0
INTC0	—	TB0F	TKMF	INTF	TB0E	TKME	INTE	EMI
INTC1	PTM0AF	PTM0PF	CTM0AF	CTM0PF	PTM0AE	PTM0PE	CTM0AE	CTM0PE
INTC2	LVF	UR0F	DEF	IICF	LVE	UR0E	DEE	IICE
INTC3	MFF	UR1F	TB1F	ADF	MFE	UR1E	TB1E	ADE
MFI	—	—	PTM1AF	PTM1PF	—	—	PTM1AE	PTM1PE

Interrupt Register List – BS86E16C

Register Name	Bit							
	7	6	5	4	3	2	1	0
INTEG	—	—	—	—	—	—	INTS1	INTS0
INTC0	—	TB0F	TKMF	INTF	TB0E	TKME	INTE	EMI
INTC1	PTM0AF	PTM0PF	CTM0AF	CTM0PF	PTM0AE	PTM0PE	CTM0AE	CTM0PE
INTC2	LVF	UR0F	DEF	SIMF	LVE	UR0E	DEE	SIME
INTC3	MFF	—	TB1F	ADF	MFE	—	TB1E	ADE
MFI	—	—	PTM1AF	PTM1PF	—	—	PTM1AE	PTM1PE

Interrupt Register List – BS86D20C

• **INTEG Register**

Bit	7	6	5	4	3	2	1	0
Name	—	—	—	—	—	—	INTS1	INTS0
R/W	—	—	—	—	—	—	R/W	R/W
POR	—	—	—	—	—	—	0	0

Bit 7~4 Unimplemented, read as “0”

Bit 1~0 **INTS1~INTS0**: Interrupt edge control for INT pin
 00: Disable
 01: Rising edge
 10: Falling edge
 11: Rising and falling edges

• **INTC0 Register**

Bit	7	6	5	4	3	2	1	0
Name	—	TB0F	TKMF	INTF	TB0E	TKME	INTE	EMI
R/W	—	R/W	R/W	R/W	R/W	R/W	R/W	R/W
POR	—	0	0	0	0	0	0	0

Bit 7 Unimplemented, read as “0”

Bit 6 **TB0F**: Time Base 0 interrupt request flag
 0: No request
 1: Interrupt request

Bit 5 **TKMF**: Touch key module interrupt request flag
 0: No request
 1: Interrupt request

Bit 4 **INTF**: INT interrupt request flag
 0: No request
 1: Interrupt request

Bit 3 **TB0E**: Time Base 0 interrupt control
 0: Disable
 1: Enable

Bit 2 **TKME**: Touch key module interrupt control
 0: Disable
 1: Enable

Bit 1 **INTE**: INT interrupt control
 0: Disable
 1: Enable

Bit 0 **EMI**: Global interrupt control
 0: Disable
 1: Enable

• **INTC1 Register**

Bit	7	6	5	4	3	2	1	0
Name	PTM0AF	PTM0PF	CTM0AF	CTM0PF	PTM0AE	PTM0PE	CTM0AE	CTM0PE
R/W	R/W	R/W	R/W	R/W	R/W	R/W	R/W	R/W
POR	0	0	0	0	0	0	0	0

Bit 7 **PTM0AF**: PTM0 Comparator A match interrupt request flag
 0: No request
 1: Interrupt request

- Bit 6 **PTM0PF**: PTM0 Comparator P match interrupt request flag
 0: No request
 1: Interrupt request
- Bit 5 **CTM0AF**: CTM0 Comparator A match interrupt request flag
 0: No request
 1: Interrupt request
- Bit 4 **CTM0PF**: CTM0 Comparator P match interrupt request flag
 0: No request
 1: Interrupt request
- Bit 3 **PTM0AE**: PTM0 Comparator A match interrupt control
 0: Disable
 1: Enable
- Bit 2 **PTM0PE**: PTM0 Comparator P match interrupt control
 0: Disable
 1: Enable
- Bit 1 **CTM0AE**: CTM0 Comparator A match interrupt control
 0: Disable
 1: Enable
- Bit 0 **CTM0PE**: CTM0 Comparator P match interrupt control
 0: Disable
 1: Enable

• **INTC2 Register – BS86C08C/BS86D12C/BS86E16C**

Bit	7	6	5	4	3	2	1	0
Name	LVF	UR0F	DEF	IICF	LVE	UR0E	DEE	IICE
R/W	R/W	R/W	R/W	R/W	R/W	R/W	R/W	R/W
POR	0	0	0	0	0	0	0	0

- Bit 7 **LVF**: LVD Interrupt request flag
 0: No request
 1: Interrupt request
- Bit 6 **UR0F**: UART0 transfer interrupt request flag
 0: No request
 1: Interrupt request
- Bit 5 **DEF**: Data EEPROM Interrupt request flag
 0: No request
 1: Interrupt request
- Bit 4 **IICF**: I²C interrupt request flag
 0: No request
 1: Interrupt request
- Bit 3 **LVE**: LVD Interrupt control
 0: Disable
 1: Enable
- Bit 2 **UR0E**: UART0 transfer interrupt control
 0: Disable
 1: Enable
- Bit 1 **DEE**: Data EEPROM Interrupt control
 0: Disable
 1: Enable
- Bit 0 **IICE**: I²C interrupt control
 0: Disable
 1: Enable

• **INTC2 Register – BS86D20C**

Bit	7	6	5	4	3	2	1	0
Name	LVF	UR0F	DEF	SIMF	LVE	UR0E	DEE	SIME
R/W	R/W	R/W	R/W	R/W	R/W	R/W	R/W	R/W
POR	0	0	0	0	0	0	0	0

- Bit 7 **LVF**: LVD Interrupt request flag
 0: No request
 1: Interrupt request
- Bit 6 **UR0F**: UART0 transfer interrupt request flag
 0: No request
 1: Interrupt request
- Bit 5 **DEF**: Data EEPROM Interrupt request flag
 0: No request
 1: Interrupt request
- Bit 4 **SIMF**: SIM interrupt request flag
 0: No request
 1: Interrupt request
- Bit 3 **LVE**: LVD Interrupt control
 0: Disable
 1: Enable
- Bit 2 **UR0E**: UART0 transfer interrupt control
 0: Disable
 1: Enable
- Bit 1 **DEE**: Data EEPROM Interrupt control
 0: Disable
 1: Enable
- Bit 0 **SIME**: SIM interrupt control
 0: Disable
 1: Enable

• **INTC3 Register – BS86C08C/BS86D12C**

Bit	7	6	5	4	3	2	1	0
Name	—	—	—	ADF	—	—	—	ADE
R/W	—	—	—	R/W	—	—	—	R/W
POR	—	—	—	0	—	—	—	0

- Bit 7~5 Unimplemented, read as “0”
- Bit 4 **ADF**: A/D Converter interrupt request flag
 0: No request
 1: Interrupt request
- Bit 3~1 Unimplemented, read as “0”
- Bit 0 **ADE**: A/D Converter interrupt control
 0: Disable
 1: Enable

• **INTC3 Register – BS86E16C**

Bit	7	6	5	4	3	2	1	0
Name	MFF	UR1F	TB1F	ADF	MFE	UR1E	TB1E	ADE
R/W	R/W	R/W	R/W	R/W	R/W	R/W	R/W	R/W
POR	0	0	0	0	0	0	0	0

- Bit 7 **MFF**: Multi-function interrupt request flag
 0: No request
 1: Interrupt request

- Bit 6 **URIF:** UART1 transfer interrupt request flag
 0: No request
 1: Interrupt request
- Bit 5 **TBIF:** Time Base 1 interrupt request flag
 0: No request
 1: Interrupt request
- Bit 4 **ADF:** A/D Converter interrupt request flag
 0: No request
 1: Interrupt request
- Bit 3 **MFE:** Multi-function interrupt control
 0: Disable
 1: Enable
- Bit 2 **URIE:** UART1 transfer interrupt control
 0: Disable
 1: Enable
- Bit 1 **TBIE:** Time Base 1 interrupt control
 0: Disable
 1: Enable
- Bit 0 **ADE:** A/D Converter interrupt control
 0: Disable
 1: Enable

• **INTC3 Register – BS86D20C**

Bit	7	6	5	4	3	2	1	0
Name	MFF	—	TB1F	ADF	MFE	—	TB1E	ADE
R/W	R/W	—	R/W	R/W	R/W	—	R/W	R/W
POR	0	—	0	0	0	—	0	0

- Bit 7 **MFF:** Multi-function interrupt request flag
 0: No request
 1: Interrupt request
- Bit 6 Unimplemented, read as “0”
- Bit 5 **TBIF:** Time Base 1 interrupt request flag
 0: No request
 1: Interrupt request
- Bit 4 **ADF:** A/D Converter interrupt request flag
 0: No request
 1: Interrupt request
- Bit 3 **MFE:** Multi-function interrupt control
 0: Disable
 1: Enable
- Bit 2 Unimplemented, read as “0”
- Bit 1 **TBIE:** Time Base 1 interrupt control
 0: Disable
 1: Enable
- Bit 0 **ADE:** A/D Converter interrupt control
 0: Disable
 1: Enable

• **MFI Register – BS86E16C/BS86D20C**

Bit	7	6	5	4	3	2	1	0
Name	—	—	PTM1AF	PTM1PF	—	—	PTM1AE	PTM1PE
R/W	—	—	R/W	R/W	—	—	R/W	R/W
POR	—	—	0	0	—	—	0	0

- Bit 7~6 Unimplemented, read as “0”
- Bit 5 **PTM1AF**: PTM1 Comparator A match interrupt request flag
 0: No request
 1: Interrupt request
 Note that this bit must be cleared to zero by the application program when the interrupt is serviced.
- Bit 4 **PTM1PF**: PTM1 Comparator P match interrupt request flag
 0: No request
 1: Interrupt request
 Note that this bit must be cleared to zero by the application program when the interrupt is serviced.
- Bit 3~2 Unimplemented, read as “0”
- Bit 1 **PTM1AE**: PTM1 Comparator A match interrupt control
 0: Disable
 1: Enable
- Bit 0 **PTM1PE**: PTM1 Comparator P match interrupt control
 0: Disable
 1: Enable

Interrupt Operation

When the conditions for an interrupt event occur, such as a Touch Key Counter overflow, a TM Comparator P or Comparator A match or A/D conversion completion, etc., the relevant interrupt request flag will be set. Whether the request flag actually generates a program jump to the relevant interrupt vector is determined by the condition of the interrupt enable bit. If the enable bit is set high then the program will jump to its relevant vector; if the enable bit is zero then although the interrupt request flag is set an actual interrupt will not be generated and the program will not jump to the relevant interrupt vector. The global interrupt enable bit, if cleared to zero, will disable all interrupts.

When an interrupt is generated, the Program Counter, which stores the address of the next instruction to be executed, will be transferred onto the stack. The Program Counter will then be loaded with a new address which will be the value of the corresponding interrupt vector. The microcontroller will then fetch its next instruction from this interrupt vector. The instruction at this vector will usually be a JMP which will jump to another section of program which is known as the interrupt service routine. Here is located the code to control the appropriate interrupt. The interrupt service routine must be terminated with a RETI, which retrieves the original Program Counter address from the stack and allows the microcontroller to continue with normal execution at the point where the interrupt occurred.

Once an interrupt subroutine is serviced, all other interrupts will be blocked, as the global interrupt enable bit, EMI bit will be cleared automatically. This will prevent any further interrupt nesting from occurring. However, if other interrupt requests occur during this interval, although the interrupt will not be immediately serviced, the request flag will still be recorded.

If an interrupt requires immediate servicing while the program is already in another interrupt service routine, the EMI bit should be set after entering the routine to allow interrupt nesting. If the stack is full, the interrupt request will not be acknowledged, even if the related interrupt is enabled, until the Stack Pointer is decremented. If immediate service is desired, the stack must be prevented from becoming full. In case of simultaneous requests, the accompanying diagram shows the priority that

is applied. All of the interrupt request flags when set will wake-up the device if it is in SLEEP or IDLE Mode, however to prevent a wake-up from occurring the corresponding flag should be set before the device is in SLEEP or IDLE Mode.

External Interrupt

The external interrupt is controlled by signal transitions on the INT pin. An external interrupt request will take place when the external interrupt request flag, INTF, is set, which will occur when a transition, whose type is chosen by the edge select bits, appears on the external interrupt pin. To allow the program to branch to its respective interrupt vector address, the global interrupt enable bit, EMI, and respective external interrupt enable bit, INTE, must first be set. Additionally the correct interrupt edge type must be selected using the INTEG register to enable the external interrupt function and to choose the trigger edge type. As the external interrupt pin is pin-shared with I/O pins, they can only be configured as an external interrupt pin if the external interrupt enable bit in the corresponding interrupt register has been set. The pin must also be setup as an input by setting the corresponding bit in the port control register. When the interrupt is enabled, the stack is not full and the correct transition type appears on the external interrupt pin, a subroutine call to the external interrupt vector, will take place. When the interrupt is serviced, the external interrupt request flags, INTF, will be automatically reset and the EMI bit will be automatically cleared to disable other interrupts. Note that any pull-high resistor selections on the external interrupt pins will remain valid even if the pin is used as an external interrupt input.

The INTEG register is used to select the type of active edge that will trigger the external interrupt. A choice of either rising or falling or both edge types can be chosen to trigger an external interrupt. Note that the INTEG register can also be used to disable the external interrupt function.

Touch Key Module Interrupt

For a Touch Key interrupt to occur, the global interrupt enable bit, EMI, and the Touch Key interrupt enable bit, TKME, must be first set. An actual Touch Key interrupt will take place when the Touch Key interrupt request flag, TMKF, is set, a situation that will occur when the time slot counter overflows. When the interrupt is enabled, the stack is not full and the Touch Key time slot counter overflow occurs, a subroutine call to the relevant interrupt vector, will take place. When the interrupt is serviced, the Touch Key interrupt request flag will be automatically reset and the EMI bit will also be automatically cleared to disable other interrupts.

Time Base Interrupts

The BS86C08C/BS86D12C devices both have one Time Base Interrupt while the BS86E16C/BS86D20C has two Time Base Interrupts. The function of the Time Base Interrupt is to provide regular time signal in the form of an internal interrupt. It is controlled by the overflow signal from its internal timer. When this happens its interrupt request flag, TBnF, will be set. To allow the program to branch to its respective interrupt vector addresses, the global interrupt enable bit, EMI and Time Base enable bit, TBnE, must first be set. When the interrupt is enabled, the stack is not full and the Time Base overflows, a subroutine call to its respective vector location will take place. When the interrupt is serviced, the interrupt request flag, TBnF, will be automatically reset and the EMI bit will be cleared to disable other interrupts.

The purpose of the Time Base Interrupt is to provide an interrupt signal at fixed time periods. Its clock source, f_{PSC0} or f_{PSC1} , originates from the internal clock source f_{SYS} , $f_{SYS}/4$, f_{SUB} or f_H and then passes through a divider, the division ratio of which is selected by programming the appropriate bits in the TBC register to obtain longer interrupt periods whose value ranges. The clock source which in turn controls the Time Base interrupt period is selected using the CLKSEL0[1:0] and CLKSEL1[1:0] bits in the PSCR register respectively.

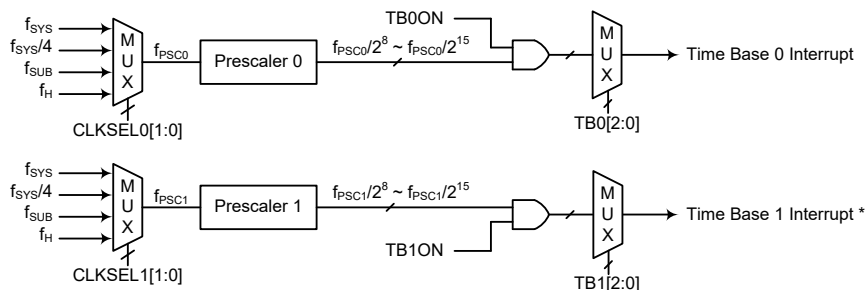

Note: The Time Base 1 Interrupt is only available for the BS86E16C/BS86D20C device.

Time Base Interrupts

• **PSCR Register – BS86C08C/BS86D12C**

Bit	7	6	5	4	3	2	1	0
Name	—	—	—	—	—	—	CLKSEL01	CLKSEL00
R/W	—	—	—	—	—	—	R/W	R/W
POR	—	—	—	—	—	—	0	0

Bit 7~2 Unimplemented, read as “0”

Bit 1~0 **CLKSEL01~CLKSEL00**: Prescaler 0 clock source f_{PSC0} selection
 00: f_{SYS}
 01: $f_{SYS}/4$
 10: f_{SUB}
 11: f_H

• **PSCR Register – BS86E16C/BS86D20C**

Bit	7	6	5	4	3	2	1	0
Name	—	—	CLKSEL11	CLKSEL10	—	—	CLKSEL01	CLKSEL00
R/W	—	—	R/W	R/W	—	—	R/W	R/W
POR	—	—	0	0	—	—	0	0

Bit 7~6 Unimplemented, read as “0”

Bit 5~4 **CLKSEL11~CLKSEL10**: Prescaler 1 clock source f_{PSC1} selection
 00: f_{SYS}
 01: $f_{SYS}/4$
 10: f_{SUB}
 11: f_H

Bit 3~2 Unimplemented, read as “0”

Bit 1~0 **CLKSEL01~CLKSEL00**: Prescaler 0 clock source f_{PSC0} selection
 00: f_{SYS}
 01: $f_{SYS}/4$
 10: f_{SUB}
 11: f_H

• **TBC Register – BS86C08C/BS86D12C**

Bit	7	6	5	4	3	2	1	0
Name	—	—	—	—	TB0ON	TB02	TB01	TB00
R/W	—	—	—	—	R/W	R/W	R/W	R/W
POR	—	—	—	—	0	0	0	0

Bit 7~4 Unimplemented, read as “0”

Bit 3 **TB0ON**: Time Base 0 Enable Control
 0: Disable
 1: Enable

Bit 2~0 **TB02~TB00**: Time Base 0 time-out period selection
 000: $2^8/f_{PSC0}$
 001: $2^9/f_{PSC0}$
 010: $2^{10}/f_{PSC0}$
 011: $2^{11}/f_{PSC0}$
 100: $2^{12}/f_{PSC0}$
 101: $2^{13}/f_{PSC0}$
 110: $2^{14}/f_{PSC0}$
 111: $2^{15}/f_{PSC0}$

• **TBC Register – BS86E16C/BS86D20C**

Bit	7	6	5	4	3	2	1	0
Name	TB1ON	TB12	TB11	TB10	TB0ON	TB02	TB01	TB00
R/W	R/W	R/W	R/W	R/W	R/W	R/W	R/W	R/W
POR	0	0	0	0	0	0	0	0

Bit 7 **TB1ON**: Time Base 1 Enable Control
 0: Disable
 1: Enable

Bit 6~4 **TB12~TB10**: Time Base 1 time-out period selection
 000: $2^8/f_{PSC1}$
 001: $2^9/f_{PSC1}$
 010: $2^{10}/f_{PSC1}$
 011: $2^{11}/f_{PSC1}$
 100: $2^{12}/f_{PSC1}$
 101: $2^{13}/f_{PSC1}$
 110: $2^{14}/f_{PSC1}$
 111: $2^{15}/f_{PSC1}$

Bit 3 **TB0ON**: Time Base 0 Enable Control
 0: Disable
 1: Enable

Bit 2~0 **TB02~TB00**: Time Base 0 time-out period selection
 000: $2^8/f_{PSC0}$
 001: $2^9/f_{PSC0}$
 010: $2^{10}/f_{PSC0}$
 011: $2^{11}/f_{PSC0}$
 100: $2^{12}/f_{PSC0}$
 101: $2^{13}/f_{PSC0}$
 110: $2^{14}/f_{PSC0}$
 111: $2^{15}/f_{PSC0}$

I²C Interrupt – BS86C08C/BS86D12C/BS86E16C

An I²C interrupt request will take place when the I²C Interrupt request flag, IICF, is set, which occurs when a byte of data has been received or transmitted by the I²C interface, or an I²C slave address match occurs, or an I²C bus time-out occurs. To allow the program to branch to its respective interrupt vector address, the global interrupt enable bit, EMI, and the Serial Interface Interrupt enable bit, IICE, must first be set. When the interrupt is enabled, the stack is not full and any of the above described situations occurs, a subroutine call to the respective Interrupt vector, will take place. When the interrupt is serviced, the Serial Interface Interrupt flag, IICF, will be automatically cleared. The EMI bit will also be automatically cleared to disable other interrupts.

Serial Interface Module Interrupt – BS86D20C

The Serial Interface Module Interrupt is also known as the SIM Interrupt. A SIM Interrupt request will take place when the SIM Interrupt request flag, SIMF, is set, which occurs when a byte of data has been received or transmitted by the SIM interface, an I²C address match or I²C time-out occurrence. To allow the program to branch to its respective interrupt vector address, the global interrupt enable bit, EMI, and the Serial Interface Interrupt enable bit, SIME, must first be set. When the interrupt is enabled, the stack is not full and any of the above described situations occurs, a subroutine call to the SIM interrupt vector, will take place. When the SIM Interface Interrupt is serviced, the interrupt request flag, SIMF, will be automatically reset and the EMI bit will be cleared to disable other interrupts.

EEPROM Interrupt

The EEPROM Write Interrupt is an individual interrupt source with its own interrupt vector. An EEPROM Write Interrupt request will take place when the EEPROM Write Interrupt request flag, DEF, is set, which occurs when an EEPROM Write cycle ends. To allow the program to branch to its respective interrupt vector address, the global interrupt enable bit, EMI, and EEPROM Write Interrupt enable bit, DEE, must first be set. When the interrupt is enabled, the stack is not full and an EEPROM Write cycle ends, a subroutine call to the respective interrupt vector will take place. When the EEPROM Write Interrupt is serviced, the DEF flag will be automatically cleared and the EMI bit will also be automatically cleared to disable other interrupts.

UART Transfer Interrupts

The UARTn Transfer Interrupt is controlled by several individual UARTn transfer conditions. When one of these conditions occurs, an interrupt pulse will be generated to get the attention of the microcontroller. These conditions are a transmitter data register empty, transmitter idle, receiver data available, receiver overrun, address detect and an RXn pin wake-up. To allow the program to branch to the respective interrupt vector addresses, the global interrupt enable bit, EMI, and the UARTn interrupt enable bit, URnE, must first be set. When the interrupt is enabled, the stack is not full and any of these conditions are created, a subroutine call to the UARTn Interrupt vector, will take place. When the UARTn Interrupt is serviced, the UARTn Interrupt flag, URnF, will be automatically cleared. The EMI bit will also be automatically cleared to disable other interrupts. However, the UnSR register flags will only be cleared when certain actions are taken by the UARTn, the details of which are given in the UART Interfaces chapter.

LVD Interrupt

The Low Voltage Detector Interrupt is an individual interrupt source with its own interrupt vector. An LVD Interrupt request will take place when the LVD Interrupt request flag, LVF, is set, which occurs when the Low Voltage Detector function detects a low power supply voltage. To allow the program to branch to its respective interrupt vector address, the global interrupt enable bit, EMI, and Low Voltage Interrupt enable bit, LVE, must first be set. When the interrupt is enabled, the stack is not full and a low voltage condition occurs, a subroutine call to the relevant interrupt vector will take place. When the Low Voltage Interrupt is serviced, the LVF flag will be automatically cleared. The EMI bit will also be automatically cleared to disable other interrupts.

A/D Converter Interrupt

The A/D Converter Interrupt is controlled by the termination of an A/D conversion process. An A/D Converter Interrupt request will take place when the A/D Converter Interrupt request flag, ADF, is set, which occurs when the A/D conversion process finishes. To allow the program to branch to its respective interrupt vector address, the global interrupt enable bit, EMI, and A/D Interrupt enable bit, ADE, must first be set. When the interrupt is enabled, the stack is not full and the A/D conversion process has ended, a subroutine call to the A/D Converter Interrupt vector will take place. When the interrupt is serviced, the A/D Converter Interrupt flag, ADF, will be automatically cleared. The EMI bit will also be automatically cleared to disable other interrupts.

Multi-function Interrupt – BS86E16C/BS86D20C

Within the BS86E16C/BS86D20C device there is one Multi-function interrupt. Unlike the other independent interrupts, this interrupt has no independent source, but rather are formed from other existing interrupt sources, namely the PTM1 interrupts.

A Multi-function interrupt request will take place when the Multi-function interrupt request flag MFF are set. The Multi-function interrupt flag will be set when any of its included functions generate an interrupt request flag. To allow the program to branch to its respective interrupt vector address, when the Multi-function interrupt is enabled and the stack is not full, and one of the interrupts contained within the Multi-function interrupt occurs, a subroutine call to the Multi-function interrupt vector will take place. When the interrupt is serviced, the related Multi-Function request flag will be automatically reset and the EMI bit will be automatically cleared to disable other interrupts.

However, it must be noted that, although the Multi-function Interrupt request flag will be automatically reset when the interrupt is serviced, the request flags from the original source of the Multi-function interrupt will not be automatically reset and must be manually reset by the application program.

TM Interrupts

The Compact and Periodic TMs have two interrupts, one comes from the comparator A match situation and the other comes from the comparator P match situation. The CTM0 and PTM0 interrupts have their own individual interrupt vectors respectively while the PTM1 are contained within the Multi-function Interrupts. For the CTM0 and PTM0 there are two interrupt request flags and two enable control bits. A TM interrupt request will take place when any of the TM request flags are set, a situation which occurs when a TM comparator P or A match situation happens.

To allow the program to branch to its respective interrupt vector address, the global interrupt enable bit, EMI, and respective TM Interrupt enable bit must first be set for the CTM0 and PTM0. However, the relevant Multi-function Interrupt enable bit, MFE, must also be set for the PTM1. When the interrupt is enabled, the stack is not full and a TM comparator match situation occurs, a subroutine call to the relevant TM Interrupt vector locations will take place. When the TM interrupt

is serviced, the EMI bit will be automatically cleared to disable other interrupts. The CTM0 or PTM0 interrupt request flag will automatically be cleared. However, for the PTM1 only the related MFF flag will be automatically cleared. The PTM1 interrupt request flags will be kept unchanged. As the PTM1 interrupt request flags will not be automatically cleared, it has to be cleared by the application program.

Interrupt Wake-up Function

Each of the interrupt functions has the capability of waking up the microcontroller when in the SLEEP or IDLE Mode. A wake-up is generated when an interrupt request flag changes from low to high and is independent of whether the interrupt is enabled or not. Therefore, even though these devices are in the SLEEP or IDLE Mode and its system oscillator stopped, situations such as external edge transitions on the external interrupt pin or a low power supply voltage may cause their respective interrupt flag to be set high and consequently generate an interrupt. Care must therefore be taken if spurious wake-up situations are to be avoided. If an interrupt wake-up function is to be disabled then the corresponding interrupt request flag should be set high before the device enters the SLEEP or IDLE Mode. The interrupt enable bits have no effect on the interrupt wake-up function.

Programming Considerations

By disabling the relevant interrupt enable bits, a requested interrupt can be prevented from being serviced, however, once an interrupt request flag is set, it will remain in this condition in the interrupt register until the corresponding interrupt is serviced or until the request flag is cleared by the application program.

Where a certain interrupt is contained within a Multi-function interrupt, then when the interrupt service routine is executed, as only the Multi-function interrupt request flags, MFF, will be automatically cleared, the individual request flag for the function needs to be cleared by the application program.

It is recommended that programs do not use the “CALL” instruction within the interrupt service subroutine. Interrupts often occur in an unpredictable manner or need to be serviced immediately. If only one stack is left and the interrupt is not well controlled, the original control sequence will be damaged once a CALL subroutine is executed in the interrupt subroutine.

Every interrupt has the capability of waking up the microcontroller when it is in the SLEEP or IDLE Mode, the wake up being generated when the interrupt request flag changes from low to high. If it is required to prevent a certain interrupt from waking up the microcontroller then its respective request flag should be first set high before enter SLEEP or IDLE Mode.

As only the Program Counter is pushed onto the stack, then when the interrupt is serviced, if the contents of the accumulator, status register or other registers are altered by the interrupt service program, their contents should be saved to the memory at the beginning of the interrupt service routine.

To return from an interrupt subroutine, either a RET or RETI instruction may be executed. The RETI instruction in addition to executing a return to the main program also automatically sets the EMI bit high to allow further interrupts. The RET instruction however only executes a return to the main program leaving the EMI bit in its present zero state and therefore disabling the execution of further interrupts.

Configuration Options

Configuration options refer to certain options within the MCU that are programmed into the device during the programming process. During the development process, these options are selected using the HT-IDE software development tools. As these options are programmed into the device using the hardware programming tools, once they are selected they cannot be changed later using the application program. All options must be defined for proper system function, the details of which are shown in the table.

No.	Options
Oscillator Option	
1	Low speed system oscillator selection – f_{SUB} : LIRC or LXT
2	HIRC frequency selection – f_{HIRC} : 8MHz, 12MHz or 16MHz

Note: 1. The low speed system oscillator selection is only available for the BS86E16C/BS86D20C device.

2. When the HIRC has been configured at a frequency shown in this table, the HIRCS1 and HIRCS0 bits should also be setup to select the same frequency to achieve the HIRC frequency accuracy specified in the A.C. Characteristics.

Application Circuits

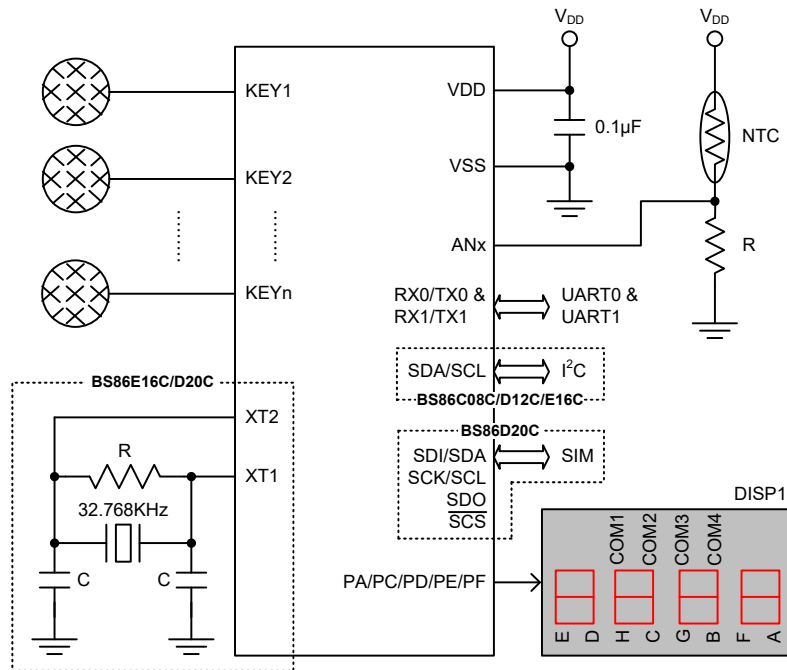

Instruction Set

Introduction

Central to the successful operation of any microcontroller is its instruction set, which is a set of program instruction codes that directs the microcontroller to perform certain operations. In the case of Holtek microcontroller, a comprehensive and flexible set of over 60 instructions is provided to enable programmers to implement their application with the minimum of programming overheads.

For easier understanding of the various instruction codes, they have been subdivided into several functional groupings.

Instruction Timing

Most instructions are implemented within one instruction cycle. The exceptions to this are branch, call, or table read instructions where two instruction cycles are required. One instruction cycle is equal to 4 system clock cycles, therefore in the case of an 8MHz system oscillator, most instructions would be implemented within 0.5 μ s and branch or call instructions would be implemented within 1 μ s. Although instructions which require one more cycle to implement are generally limited to the JMP, CALL, RET, RETI and table read instructions, it is important to realize that any other instructions which involve manipulation of the Program Counter Low register or PCL will also take one more cycle to implement. As instructions which change the contents of the PCL will imply a direct jump to that new address, one more cycle will be required. Examples of such instructions would be “CLR PCL” or “MOV PCL, A”. For the case of skip instructions, it must be noted that if the result of the comparison involves a skip operation then this will also take one more cycle, if no skip is involved then only one cycle is required.

Moving and Transferring Data

The transfer of data within the microcontroller program is one of the most frequently used operations. Making use of several kinds of MOV instructions, data can be transferred from registers to the Accumulator and vice-versa as well as being able to move specific immediate data directly into the Accumulator. One of the most important data transfer applications is to receive data from the input ports and transfer data to the output ports.

Arithmetic Operations

The ability to perform certain arithmetic operations and data manipulation is a necessary feature of most microcontroller applications. Within the Holtek microcontroller instruction set are a range of add and subtract instruction mnemonics to enable the necessary arithmetic to be carried out. Care must be taken to ensure correct handling of carry and borrow data when results exceed 255 for addition and less than 0 for subtraction. The increment and decrement instructions such as INC, INCA, DEC and DECA provide a simple means of increasing or decreasing by a value of one of the values in the destination specified.

Logical and Rotate Operation

The standard logical operations such as AND, OR, XOR and CPL all have their own instruction within the Holtek microcontroller instruction set. As with the case of most instructions involving data manipulation, data must pass through the Accumulator which may involve additional programming steps. In all logical data operations, the zero flag may be set if the result of the operation is zero. Another form of logical data manipulation comes from the rotate instructions such as RR, RL, RRC and RLC which provide a simple means of rotating one bit right or left. Different rotate instructions exist depending on program requirements. Rotate instructions are useful for serial port programming applications where data can be rotated from an internal register into the Carry bit from where it can be examined and the necessary serial bit set high or low. Another application which rotate data operations are used is to implement multiplication and division calculations.

Branches and Control Transfer

Program branching takes the form of either jumps to specified locations using the JMP instruction or to a subroutine using the CALL instruction. They differ in the sense that in the case of a subroutine call, the program must return to the instruction immediately when the subroutine has been carried out. This is done by placing a return instruction “RET” in the subroutine which will cause the program to jump back to the address right after the CALL instruction. In the case of a JMP instruction, the program simply jumps to the desired location. There is no requirement to jump back to the original jumping off point as in the case of the CALL instruction. One special and extremely useful set of branch instructions are the conditional branches. Here a decision is first made regarding the condition of a certain data memory or individual bits. Depending upon the conditions, the program will continue with the next instruction or skip over it and jump to the following instruction. These instructions are the key to decision making and branching within the program perhaps determined by the condition of certain input switches or by the condition of internal data bits.

Bit Operations

The ability to provide single bit operations on Data Memory is an extremely flexible feature of all Holtek microcontrollers. This feature is especially useful for output port bit programming where individual bits or port pins can be directly set high or low using either the “SET [m].i” or “CLR [m].i” instructions respectively. The feature removes the need for programmers to first read the 8-bit output port, manipulate the input data to ensure that other bits are not changed and then output the port with the correct new data. This read-modify-write process is taken care of automatically when these bit operation instructions are used.

Table Read Operations

Data storage is normally implemented by using registers. However, when working with large amounts of fixed data, the volume involved often makes it inconvenient to store the fixed data in the Data Memory. To overcome this problem, Holtek microcontrollers allow an area of Program Memory to be setup as a table where data can be directly stored. A set of easy to use instructions provides the means by which this fixed data can be referenced and retrieved from the Program Memory.

Other Operations

In addition to the above functional instructions, a range of other instructions also exist such as the “HALT” instruction for Power-down operations and instructions to control the operation of the Watchdog Timer for reliable program operations under extreme electric or electromagnetic environments. For their relevant operations, refer to the functional related sections.

Instruction Set Summary

The instructions related to the data memory access in the following table can be used when the desired data memory is located in Data Memory sector 0.

Table Conventions

x: Bits immediate data
 m: Data Memory address
 A: Accumulator
 i: 0~7 number of bits
 addr: Program memory address

Mnemonic	Description	Cycles	Flag Affected
Arithmetic			
ADD A,[m]	Add Data Memory to ACC	1	Z, C, AC, OV, SC
ADDM A,[m]	Add ACC to Data Memory	1 ^{Note}	Z, C, AC, OV, SC
ADD A,x	Add immediate data to ACC	1	Z, C, AC, OV, SC
ADC A,[m]	Add Data Memory to ACC with Carry	1	Z, C, AC, OV, SC
ADCM A,[m]	Add ACC to Data memory with Carry	1 ^{Note}	Z, C, AC, OV, SC
SUB A,x	Subtract immediate data from the ACC	1	Z, C, AC, OV, SC, CZ
SUB A,[m]	Subtract Data Memory from ACC	1	Z, C, AC, OV, SC, CZ
SUBM A,[m]	Subtract Data Memory from ACC with result in Data Memory	1 ^{Note}	Z, C, AC, OV, SC, CZ
SBC A,x	Subtract immediate data from ACC with Carry	1	Z, C, AC, OV, SC, CZ
SBC A,[m]	Subtract Data Memory from ACC with Carry	1	Z, C, AC, OV, SC, CZ
SBCM A,[m]	Subtract Data Memory from ACC with Carry, result in Data Memory	1 ^{Note}	Z, C, AC, OV, SC, CZ
DAA [m]	Decimal adjust ACC for Addition with result in Data Memory	1 ^{Note}	C
Logic Operation			
AND A,[m]	Logical AND Data Memory to ACC	1	Z
OR A,[m]	Logical OR Data Memory to ACC	1	Z
XOR A,[m]	Logical XOR Data Memory to ACC	1	Z
ANDM A,[m]	Logical AND ACC to Data Memory	1 ^{Note}	Z
ORM A,[m]	Logical OR ACC to Data Memory	1 ^{Note}	Z
XORM A,[m]	Logical XOR ACC to Data Memory	1 ^{Note}	Z
AND A,x	Logical AND immediate Data to ACC	1	Z
OR A,x	Logical OR immediate Data to ACC	1	Z
XOR A,x	Logical XOR immediate Data to ACC	1	Z
CPL [m]	Complement Data Memory	1 ^{Note}	Z
CPLA [m]	Complement Data Memory with result in ACC	1	Z
Increment & Decrement			
INCA [m]	Increment Data Memory with result in ACC	1	Z
INC [m]	Increment Data Memory	1 ^{Note}	Z
DECA [m]	Decrement Data Memory with result in ACC	1	Z
DEC [m]	Decrement Data Memory	1 ^{Note}	Z
Rotate			
RRA [m]	Rotate Data Memory right with result in ACC	1	None
RR [m]	Rotate Data Memory right	1 ^{Note}	None
RRCA [m]	Rotate Data Memory right through Carry with result in ACC	1	C
RRC [m]	Rotate Data Memory right through Carry	1 ^{Note}	C
RLA [m]	Rotate Data Memory left with result in ACC	1	None
RL [m]	Rotate Data Memory left	1 ^{Note}	None
RLCA [m]	Rotate Data Memory left through Carry with result in ACC	1	C
RLC [m]	Rotate Data Memory left through Carry	1 ^{Note}	C

Mnemonic	Description	Cycles	Flag Affected
Data Move			
MOV A,[m]	Move Data Memory to ACC	1	None
MOV [m],A	Move ACC to Data Memory	1 ^{Note}	None
MOV A,x	Move immediate data to ACC	1	None
Bit Operation			
CLR [m].i	Clear bit of Data Memory	1 ^{Note}	None
SET [m].i	Set bit of Data Memory	1 ^{Note}	None
Branch Operation			
JMP addr	Jump unconditionally	2	None
SZ [m]	Skip if Data Memory is zero	1 ^{Note}	None
SZA [m]	Skip if Data Memory is zero with data movement to ACC	1 ^{Note}	None
SZ [m].i	Skip if bit i of Data Memory is zero	1 ^{Note}	None
SNZ [m]	Skip if Data Memory is not zero	1 ^{Note}	None
SNZ [m].i	Skip if bit i of Data Memory is not zero	1 ^{Note}	None
SIZ [m]	Skip if increment Data Memory is zero	1 ^{Note}	None
SDZ [m]	Skip if decrement Data Memory is zero	1 ^{Note}	None
SIZA [m]	Skip if increment Data Memory is zero with result in ACC	1 ^{Note}	None
SDZA [m]	Skip if decrement Data Memory is zero with result in ACC	1 ^{Note}	None
CALL addr	Subroutine call	2	None
RET	Return from subroutine	2	None
RET A,x	Return from subroutine and load immediate data to ACC	2	None
RETI	Return from interrupt	2	None
Table Read Operation			
TABRD [m]	Read table (specific page) to TBLH and Data Memory	2 ^{Note}	None
TABRDL [m]	Read table (last page) to TBLH and Data Memory	2 ^{Note}	None
ITABRD [m]	Increment table pointer TBLP first and Read table (specific page) to TBLH and Data Memory	2 ^{Note}	None
ITABRDL [m]	Increment table pointer TBLP first and Read table (last page) to TBLH and Data Memory	2 ^{Note}	None
Miscellaneous			
NOP	No operation	1	None
CLR [m]	Clear Data Memory	1 ^{Note}	None
SET [m]	Set Data Memory	1 ^{Note}	None
CLR WDT	Clear Watchdog Timer	1	TO, PDF
SWAP [m]	Swap nibbles of Data Memory	1 ^{Note}	None
SWAPA [m]	Swap nibbles of Data Memory with result in ACC	1	None
HALT	Enter power down mode	1	TO, PDF

Note: 1. For skip instructions, if the result of the comparison involves a skip then two cycles are required, if no skip takes place only one cycle is required.

2. Any instruction which changes the contents of the PCL will also require 2 cycles for execution.

Extended Instruction Set

The extended instructions are used to support the full range address access for the data memory. When the accessed data memory is located in any data memory sector except sector 0, the extended instruction can be used to directly access the data memory instead of using the indirect addressing access. This can not only reduce the use of Flash memory space but also improve the CPU execution efficiency.

Mnemonic	Description	Cycles	Flag Affected
Arithmetic			
LADD A,[m]	Add Data Memory to ACC	2	Z, C, AC, OV, SC
LADDM A,[m]	Add ACC to Data Memory	2 ^{Note}	Z, C, AC, OV, SC
LADC A,[m]	Add Data Memory to ACC with Carry	2	Z, C, AC, OV, SC
LADCM A,[m]	Add ACC to Data memory with Carry	2 ^{Note}	Z, C, AC, OV, SC
LSUB A,[m]	Subtract Data Memory from ACC	2	Z, C, AC, OV, SC, CZ
LSUBM A,[m]	Subtract Data Memory from ACC with result in Data Memory	2 ^{Note}	Z, C, AC, OV, SC, CZ
LSBC A,[m]	Subtract Data Memory from ACC with Carry	2	Z, C, AC, OV, SC, CZ
LSBCM A,[m]	Subtract Data Memory from ACC with Carry, result in Data Memory	2 ^{Note}	Z, C, AC, OV, SC, CZ
LDAA [m]	Decimal adjust ACC for Addition with result in Data Memory	2 ^{Note}	C
Logic Operation			
LAND A,[m]	Logical AND Data Memory to ACC	2	Z
LOR A,[m]	Logical OR Data Memory to ACC	2	Z
LXOR A,[m]	Logical XOR Data Memory to ACC	2	Z
LANDM A,[m]	Logical AND ACC to Data Memory	2 ^{Note}	Z
LORM A,[m]	Logical OR ACC to Data Memory	2 ^{Note}	Z
LXORM A,[m]	Logical XOR ACC to Data Memory	2 ^{Note}	Z
LCPL [m]	Complement Data Memory	2 ^{Note}	Z
LCPLA [m]	Complement Data Memory with result in ACC	2	Z
Increment & Decrement			
LINCA [m]	Increment Data Memory with result in ACC	2	Z
LINC [m]	Increment Data Memory	2 ^{Note}	Z
LDECA [m]	Decrement Data Memory with result in ACC	2	Z
LDEC [m]	Decrement Data Memory	2 ^{Note}	Z
Rotate			
LRRRA [m]	Rotate Data Memory right with result in ACC	2	None
LRR [m]	Rotate Data Memory right	2 ^{Note}	None
LRRCA [m]	Rotate Data Memory right through Carry with result in ACC	2	C
LRRC [m]	Rotate Data Memory right through Carry	2 ^{Note}	C
LRLA [m]	Rotate Data Memory left with result in ACC	2	None
LRL [m]	Rotate Data Memory left	2 ^{Note}	None
LRLCA [m]	Rotate Data Memory left through Carry with result in ACC	2	C
LRLC [m]	Rotate Data Memory left through Carry	2 ^{Note}	C
Data Move			
LMOV A,[m]	Move Data Memory to ACC	2	None
LMOV [m],A	Move ACC to Data Memory	2 ^{Note}	None
Bit Operation			
LCLR [m].i	Clear bit of Data Memory	2 ^{Note}	None
LSET [m].i	Set bit of Data Memory	2 ^{Note}	None

Mnemonic	Description	Cycles	Flag Affected
Branch			
LSZ [m]	Skip if Data Memory is zero	2 ^{Note}	None
LSZA [m]	Skip if Data Memory is zero with data movement to ACC	2 ^{Note}	None
LSNZ [m]	Skip if Data Memory is not zero	2 ^{Note}	None
LSZ [m].i	Skip if bit i of Data Memory is zero	2 ^{Note}	None
LSNZ [m].i	Skip if bit i of Data Memory is not zero	2 ^{Note}	None
LSIZ [m]	Skip if increment Data Memory is zero	2 ^{Note}	None
LSDZ [m]	Skip if decrement Data Memory is zero	2 ^{Note}	None
LSIZA [m]	Skip if increment Data Memory is zero with result in ACC	2 ^{Note}	None
LSDZA [m]	Skip if decrement Data Memory is zero with result in ACC	2 ^{Note}	None
Table Read			
LTABRD [m]	Read table (specific page) to TBLH and Data Memory	3 ^{Note}	None
LTABRDL [m]	Read table (last page) to TBLH and Data Memory	3 ^{Note}	None
LITABRD [m]	Increment table pointer TBLP first and Read table (specific page) to TBLH and Data Memory	3 ^{Note}	None
LITABRDL [m]	Increment table pointer TBLP first and Read table (last page) to TBLH and Data Memory	3 ^{Note}	None
Miscellaneous			
LCLR [m]	Clear Data Memory	2 ^{Note}	None
LSET [m]	Set Data Memory	2 ^{Note}	None
LSWAP [m]	Swap nibbles of Data Memory	2 ^{Note}	None
LSWAPA [m]	Swap nibbles of Data Memory with result in ACC	2	None

- Note: 1. For these extended skip instructions, if the result of the comparison involves a skip then three cycles are required, if no skip takes place two cycles is required.
2. Any extended instruction which changes the contents of the PCL register will also require three cycles for execution.

Instruction Definition

ADC A,[m]	Add Data Memory to ACC with Carry
Description	The contents of the specified Data Memory, Accumulator and the carry flag are added. The result is stored in the Accumulator.
Operation	$ACC \leftarrow ACC + [m] + C$
Affected flag(s)	OV, Z, AC, C, SC
ADCM A,[m]	Add ACC to Data Memory with Carry
Description	The contents of the specified Data Memory, Accumulator and the carry flag are added. The result is stored in the specified Data Memory.
Operation	$[m] \leftarrow ACC + [m] + C$
Affected flag(s)	OV, Z, AC, C, SC
ADD A,[m]	Add Data Memory to ACC
Description	The contents of the specified Data Memory and the Accumulator are added. The result is stored in the Accumulator.
Operation	$ACC \leftarrow ACC + [m]$
Affected flag(s)	OV, Z, AC, C, SC
ADD A,x	Add immediate data to ACC
Description	The contents of the Accumulator and the specified immediate data are added. The result is stored in the Accumulator.
Operation	$ACC \leftarrow ACC + x$
Affected flag(s)	OV, Z, AC, C, SC
ADDM A,[m]	Add ACC to Data Memory
Description	The contents of the specified Data Memory and the Accumulator are added. The result is stored in the specified Data Memory.
Operation	$[m] \leftarrow ACC + [m]$
Affected flag(s)	OV, Z, AC, C, SC
AND A,[m]	Logical AND Data Memory to ACC
Description	Data in the Accumulator and the specified Data Memory perform a bitwise logical AND operation. The result is stored in the Accumulator.
Operation	$ACC \leftarrow ACC \text{ "AND" } [m]$
Affected flag(s)	Z
AND A,x	Logical AND immediate data to ACC
Description	Data in the Accumulator and the specified immediate data perform a bit wise logical AND operation. The result is stored in the Accumulator.
Operation	$ACC \leftarrow ACC \text{ "AND" } x$
Affected flag(s)	Z
ANDM A,[m]	Logical AND ACC to Data Memory
Description	Data in the specified Data Memory and the Accumulator perform a bitwise logical AND operation. The result is stored in the Data Memory.
Operation	$[m] \leftarrow ACC \text{ "AND" } [m]$
Affected flag(s)	Z

CALL addr	Subroutine call
Description	Unconditionally calls a subroutine at the specified address. The Program Counter then increments by 1 to obtain the address of the next instruction which is then pushed onto the stack. The specified address is then loaded and the program continues execution from this new address. As this instruction requires an additional operation, it is a two cycle instruction.
Operation	Stack ← Program Counter + 1 Program Counter ← addr
Affected flag(s)	None
CLR [m]	Clear Data Memory
Description	Each bit of the specified Data Memory is cleared to 0.
Operation	[m] ← 00H
Affected flag(s)	None
CLR [m].i	Clear bit of Data Memory
Description	Bit i of the specified Data Memory is cleared to 0.
Operation	[m].i ← 0
Affected flag(s)	None
CLR WDT	Clear Watchdog Timer
Description	The TO, PDF flags and the WDT are all cleared.
Operation	WDT cleared TO ← 0 PDF ← 0
Affected flag(s)	TO, PDF
CPL [m]	Complement Data Memory
Description	Each bit of the specified Data Memory is logically complemented (1's complement). Bits which previously contained a 1 are changed to 0 and vice versa.
Operation	[m] ← $\overline{[m]}$
Affected flag(s)	Z
CPLA [m]	Complement Data Memory with result in ACC
Description	Each bit of the specified Data Memory is logically complemented (1's complement). Bits which previously contained a 1 are changed to 0 and vice versa. The complemented result is stored in the Accumulator and the contents of the Data Memory remain unchanged.
Operation	ACC ← $\overline{[m]}$
Affected flag(s)	Z
DAA [m]	Decimal-Adjust ACC for addition with result in Data Memory
Description	Convert the contents of the Accumulator value to a BCD (Binary Coded Decimal) value resulting from the previous addition of two BCD variables. If the low nibble is greater than 9 or if AC flag is set, then a value of 6 will be added to the low nibble. Otherwise the low nibble remains unchanged. If the high nibble is greater than 9 or if the C flag is set, then a value of 6 will be added to the high nibble. Essentially, the decimal conversion is performed by adding 00H, 06H, 60H or 66H depending on the Accumulator and flag conditions. Only the C flag may be affected by this instruction which indicates that if the original BCD sum is greater than 100, it allows multiple precision decimal addition.
Operation	[m] ← ACC + 00H or [m] ← ACC + 06H or [m] ← ACC + 60H or [m] ← ACC + 66H
Affected flag(s)	C

DEC [m]	Decrement Data Memory
Description	Data in the specified Data Memory is decremented by 1.
Operation	$[m] \leftarrow [m] - 1$
Affected flag(s)	Z
DECA [m]	Decrement Data Memory with result in ACC
Description	Data in the specified Data Memory is decremented by 1. The result is stored in the Accumulator. The contents of the Data Memory remain unchanged.
Operation	$ACC \leftarrow [m] - 1$
Affected flag(s)	Z
HALT	Enter power down mode
Description	This instruction stops the program execution and turns off the system clock. The contents of the Data Memory and registers are retained. The WDT and prescaler are cleared. The power down flag PDF is set and the WDT time-out flag TO is cleared.
Operation	$TO \leftarrow 0$ $PDF \leftarrow 1$
Affected flag(s)	TO, PDF
INC [m]	Increment Data Memory
Description	Data in the specified Data Memory is incremented by 1.
Operation	$[m] \leftarrow [m] + 1$
Affected flag(s)	Z
INCA [m]	Increment Data Memory with result in ACC
Description	Data in the specified Data Memory is incremented by 1. The result is stored in the Accumulator. The contents of the Data Memory remain unchanged.
Operation	$ACC \leftarrow [m] + 1$
Affected flag(s)	Z
JMP addr	Jump unconditionally
Description	The contents of the Program Counter are replaced with the specified address. Program execution then continues from this new address. As this requires the insertion of a dummy instruction while the new address is loaded, it is a two cycle instruction.
Operation	Program Counter \leftarrow addr
Affected flag(s)	None
MOV A,[m]	Move Data Memory to ACC
Description	The contents of the specified Data Memory are copied to the Accumulator.
Operation	$ACC \leftarrow [m]$
Affected flag(s)	None
MOV A,x	Move immediate data to ACC
Description	The immediate data specified is loaded into the Accumulator.
Operation	$ACC \leftarrow x$
Affected flag(s)	None
MOV [m],A	Move ACC to Data Memory
Description	The contents of the Accumulator are copied to the specified Data Memory.
Operation	$[m] \leftarrow ACC$
Affected flag(s)	None

NOP	No operation
Description	No operation is performed. Execution continues with the next instruction.
Operation	No operation
Affected flag(s)	None
OR A,[m]	Logical OR Data Memory to ACC
Description	Data in the Accumulator and the specified Data Memory perform a bitwise logical OR operation. The result is stored in the Accumulator.
Operation	ACC ← ACC "OR" [m]
Affected flag(s)	Z
OR A,x	Logical OR immediate data to ACC
Description	Data in the Accumulator and the specified immediate data perform a bitwise logical OR operation. The result is stored in the Accumulator.
Operation	ACC ← ACC "OR" x
Affected flag(s)	Z
ORM A,[m]	Logical OR ACC to Data Memory
Description	Data in the specified Data Memory and the Accumulator perform a bitwise logical OR operation. The result is stored in the Data Memory.
Operation	[m] ← ACC "OR" [m]
Affected flag(s)	Z
RET	Return from subroutine
Description	The Program Counter is restored from the stack. Program execution continues at the restored address.
Operation	Program Counter ← Stack
Affected flag(s)	None
RET A,x	Return from subroutine and load immediate data to ACC
Description	The Program Counter is restored from the stack and the Accumulator loaded with the specified immediate data. Program execution continues at the restored address.
Operation	Program Counter ← Stack ACC ← x
Affected flag(s)	None
RETI	Return from interrupt
Description	The Program Counter is restored from the stack and the interrupts are re-enabled by setting the EMI bit. EMI is the master interrupt global enable bit. If an interrupt was pending when the RETI instruction is executed, the pending Interrupt routine will be processed before returning to the main program.
Operation	Program Counter ← Stack EMI ← 1
Affected flag(s)	None
RL [m]	Rotate Data Memory left
Description	The contents of the specified Data Memory are rotated left by 1 bit with bit 7 rotated into bit 0.
Operation	[m].(i+1) ← [m].i; (i=0~6) [m].0 ← [m].7
Affected flag(s)	None

RLA [m]	Rotate Data Memory left with result in ACC
Description	The contents of the specified Data Memory are rotated left by 1 bit with bit 7 rotated into bit 0. The rotated result is stored in the Accumulator and the contents of the Data Memory remain unchanged.
Operation	ACC.(i+1) ← [m].i; (i=0~6) ACC.0 ← [m].7
Affected flag(s)	None
RLC [m]	Rotate Data Memory left through Carry
Description	The contents of the specified Data Memory and the carry flag are rotated left by 1 bit. Bit 7 replaces the Carry bit and the original carry flag is rotated into bit 0.
Operation	[m].(i+1) ← [m].i; (i=0~6) [m].0 ← C C ← [m].7
Affected flag(s)	C
RLCA [m]	Rotate Data Memory left through Carry with result in ACC
Description	Data in the specified Data Memory and the carry flag are rotated left by 1 bit. Bit 7 replaces the Carry bit and the original carry flag is rotated into the bit 0. The rotated result is stored in the Accumulator and the contents of the Data Memory remain unchanged.
Operation	ACC.(i+1) ← [m].i; (i=0~6) ACC.0 ← C C ← [m].7
Affected flag(s)	C
RR [m]	Rotate Data Memory right
Description	The contents of the specified Data Memory are rotated right by 1 bit with bit 0 rotated into bit 7.
Operation	[m].i ← [m].(i+1); (i=0~6) [m].7 ← [m].0
Affected flag(s)	None
RRA [m]	Rotate Data Memory right with result in ACC
Description	Data in the specified Data Memory is rotated right by 1 bit with bit 0 rotated into bit 7. The rotated result is stored in the Accumulator and the contents of the Data Memory remain unchanged.
Operation	ACC.i ← [m].(i+1); (i=0~6) ACC.7 ← [m].0
Affected flag(s)	None
RRC [m]	Rotate Data Memory right through Carry
Description	The contents of the specified Data Memory and the carry flag are rotated right by 1 bit. Bit 0 replaces the Carry bit and the original carry flag is rotated into bit 7.
Operation	[m].i ← [m].(i+1); (i=0~6) [m].7 ← C C ← [m].0
Affected flag(s)	C

RRCA [m]	Rotate Data Memory right through Carry with result in ACC
Description	Data in the specified Data Memory and the carry flag are rotated right by 1 bit. Bit 0 replaces the Carry bit and the original carry flag is rotated into bit 7. The rotated result is stored in the Accumulator and the contents of the Data Memory remain unchanged.
Operation	ACC.i ← [m].(i+1); (i=0~6) ACC.7 ← C C ← [m].0
Affected flag(s)	C
SBC A,[m]	Subtract Data Memory from ACC with Carry
Description	The contents of the specified Data Memory and the complement of the carry flag are subtracted from the Accumulator. The result is stored in the Accumulator. Note that if the result of subtraction is negative, the C flag will be cleared to 0, otherwise if the result is positive or zero, the C flag will be set to 1.
Operation	ACC ← ACC – [m] – \bar{C}
Affected flag(s)	OV, Z, AC, C, SC, CZ
SBC A, x	Subtract immediate data from ACC with Carry
Description	The immediate data and the complement of the carry flag are subtracted from the Accumulator. The result is stored in the Accumulator. Note that if the result of subtraction is negative, the C flag will be cleared to 0, otherwise if the result is positive or zero, the C flag will be set to 1.
Operation	ACC ← ACC – [m] – \bar{C}
Affected flag(s)	OV, Z, AC, C, SC, CZ
SBCM A,[m]	Subtract Data Memory from ACC with Carry and result in Data Memory
Description	The contents of the specified Data Memory and the complement of the carry flag are subtracted from the Accumulator. The result is stored in the Data Memory. Note that if the result of subtraction is negative, the C flag will be cleared to 0, otherwise if the result is positive or zero, the C flag will be set to 1.
Operation	[m] ← ACC – [m] – \bar{C}
Affected flag(s)	OV, Z, AC, C, SC, CZ
SDZ [m]	Skip if decrement Data Memory is 0
Description	The contents of the specified Data Memory are first decremented by 1. If the result is 0 the following instruction is skipped. As this requires the insertion of a dummy instruction while the next instruction is fetched, it is a two cycle instruction. If the result is not 0 the program proceeds with the following instruction.
Operation	[m] ← [m] – 1 Skip if [m]=0
Affected flag(s)	None
SDZA [m]	Skip if decrement Data Memory is zero with result in ACC
Description	The contents of the specified Data Memory are first decremented by 1. If the result is 0, the following instruction is skipped. The result is stored in the Accumulator but the specified Data Memory contents remain unchanged. As this requires the insertion of a dummy instruction while the next instruction is fetched, it is a two cycle instruction. If the result is not 0, the program proceeds with the following instruction.
Operation	ACC ← [m] – 1 Skip if ACC=0
Affected flag(s)	None

SET [m]	Set Data Memory
Description	Each bit of the specified Data Memory is set to 1.
Operation	$[m] \leftarrow FFH$
Affected flag(s)	None
SET [m].i	Set bit of Data Memory
Description	Bit i of the specified Data Memory is set to 1.
Operation	$[m].i \leftarrow 1$
Affected flag(s)	None
SIZ [m]	Skip if increment Data Memory is 0
Description	The contents of the specified Data Memory are first incremented by 1. If the result is 0, the following instruction is skipped. As this requires the insertion of a dummy instruction while the next instruction is fetched, it is a two cycle instruction. If the result is not 0 the program proceeds with the following instruction.
Operation	$[m] \leftarrow [m] + 1$ Skip if $[m]=0$
Affected flag(s)	None
SIZA [m]	Skip if increment Data Memory is zero with result in ACC
Description	The contents of the specified Data Memory are first incremented by 1. If the result is 0, the following instruction is skipped. The result is stored in the Accumulator but the specified Data Memory contents remain unchanged. As this requires the insertion of a dummy instruction while the next instruction is fetched, it is a two cycle instruction. If the result is not 0 the program proceeds with the following instruction.
Operation	$ACC \leftarrow [m] + 1$ Skip if $ACC=0$
Affected flag(s)	None
SNZ [m].i	Skip if bit i of Data Memory is not 0
Description	If bit i of the specified Data Memory is not 0, the following instruction is skipped. As this requires the insertion of a dummy instruction while the next instruction is fetched, it is a two cycle instruction. If the result is 0 the program proceeds with the following instruction.
Operation	Skip if $[m].i \neq 0$
Affected flag(s)	None
SNZ [m]	Skip if Data Memory is not 0
Description	The contents of the specified Data Memory are read out and then written back to the specified Data Memory again. If the specified Data Memory is not 0, the following instruction is skipped. As this requires the insertion of a dummy instruction while the next instruction is fetched, it is a two cycle instruction. If the result is 0 the program proceeds with the following instruction.
Operation	Skip if $[m] \neq 0$
Affected flag(s)	None
SUB A,[m]	Subtract Data Memory from ACC
Description	The specified Data Memory is subtracted from the contents of the Accumulator. The result is stored in the Accumulator. Note that if the result of subtraction is negative, the C flag will be cleared to 0, otherwise if the result is positive or zero, the C flag will be set to 1.
Operation	$ACC \leftarrow ACC - [m]$
Affected flag(s)	OV, Z, AC, C, SC, CZ

SUBM A,[m]	Subtract Data Memory from ACC with result in Data Memory
Description	The specified Data Memory is subtracted from the contents of the Accumulator. The result is stored in the Data Memory. Note that if the result of subtraction is negative, the C flag will be cleared to 0, otherwise if the result is positive or zero, the C flag will be set to 1.
Operation	$[m] \leftarrow ACC - [m]$
Affected flag(s)	OV, Z, AC, C, SC, CZ
SUB A,x	Subtract immediate data from ACC
Description	The immediate data specified by the code is subtracted from the contents of the Accumulator. The result is stored in the Accumulator. Note that if the result of subtraction is negative, the C flag will be cleared to 0, otherwise if the result is positive or zero, the C flag will be set to 1.
Operation	$ACC \leftarrow ACC - x$
Affected flag(s)	OV, Z, AC, C, SC, CZ
SWAP [m]	Swap nibbles of Data Memory
Description	The low-order and high-order nibbles of the specified Data Memory are interchanged.
Operation	$[m].3 \sim [m].0 \leftrightarrow [m].7 \sim [m].4$
Affected flag(s)	None
SWAPA [m]	Swap nibbles of Data Memory with result in ACC
Description	The low-order and high-order nibbles of the specified Data Memory are interchanged. The result is stored in the Accumulator. The contents of the Data Memory remain unchanged.
Operation	$ACC.3 \sim ACC.0 \leftarrow [m].7 \sim [m].4$ $ACC.7 \sim ACC.4 \leftarrow [m].3 \sim [m].0$
Affected flag(s)	None
SZ [m]	Skip if Data Memory is 0
Description	The contents of the specified Data Memory are read out and then written back to the specified Data Memory again. If the contents of the specified Data Memory is 0, the following instruction is skipped. As this requires the insertion of a dummy instruction while the next instruction is fetched, it is a two cycle instruction. If the result is not 0 the program proceeds with the following instruction.
Operation	Skip if $[m]=0$
Affected flag(s)	None
SZA [m]	Skip if Data Memory is 0 with data movement to ACC
Description	The contents of the specified Data Memory are copied to the Accumulator. If the value is zero, the following instruction is skipped. As this requires the insertion of a dummy instruction while the next instruction is fetched, it is a two cycle instruction. If the result is not 0 the program proceeds with the following instruction.
Operation	$ACC \leftarrow [m]$ Skip if $[m]=0$
Affected flag(s)	None
SZ [m].i	Skip if bit i of Data Memory is 0
Description	If bit i of the specified Data Memory is 0, the following instruction is skipped. As this requires the insertion of a dummy instruction while the next instruction is fetched, it is a two cycle instruction. If the result is not 0, the program proceeds with the following instruction.
Operation	Skip if $[m].i=0$
Affected flag(s)	None

TABRD [m]	Read table (specific page) to TBLH and Data Memory
Description	The low byte of the program code (specific page) addressed by the table pointer (TBLP and TBHP) is moved to the specified Data Memory and the high byte moved to TBLH.
Operation	[m] ← program code (low byte) TBLH ← program code (high byte)
Affected flag(s)	None
TABRDL [m]	Read table (last page) to TBLH and Data Memory
Description	The low byte of the program code (last page) addressed by the table pointer (TBLP) is moved to the specified Data Memory and the high byte moved to TBLH.
Operation	[m] ← program code (low byte) TBLH ← program code (high byte)
Affected flag(s)	None
ITABRD [m]	Increment table pointer low byte first and read table (specific page) to TBLH and Data Memory
Description	Increment table pointer low byte, TBLP, first and then the program code (specific page) addressed by the table pointer (TBHP and TBLP) is moved to the specified Data Memory and the high byte moved to TBLH.
Operation	[m] ← program code (low byte) TBLH ← program code (high byte)
Affected flag(s)	None
ITABRDL [m]	Increment table pointer low byte first and read table (last page) to TBLH and Data Memory
Description	Increment table pointer low byte, TBLP, first and then the low byte of the program code (last page) addressed by the table pointer (TBLP) is moved to the specified Data Memory and the high byte moved to TBLH.
Operation	[m] ← program code (low byte) TBLH ← program code (high byte)
Affected flag(s)	None
XOR A,[m]	Logical XOR Data Memory to ACC
Description	Data in the Accumulator and the specified Data Memory perform a bitwise logical XOR operation. The result is stored in the Accumulator.
Operation	ACC ← ACC "XOR" [m]
Affected flag(s)	Z
XORM A,[m]	Logical XOR ACC to Data Memory
Description	Data in the specified Data Memory and the Accumulator perform a bitwise logical XOR operation. The result is stored in the Data Memory.
Operation	[m] ← ACC "XOR" [m]
Affected flag(s)	Z
XOR A,x	Logical XOR immediate data to ACC
Description	Data in the Accumulator and the specified immediate data perform a bitwise logical XOR operation. The result is stored in the Accumulator.
Operation	ACC ← ACC "XOR" x
Affected flag(s)	Z

Extended Instruction Definition

The extended instructions are used to directly access the data stored in any data memory sections.

LADC A,[m]	Add Data Memory to ACC with Carry
Description	The contents of the specified Data Memory, Accumulator and the carry flag are added. The result is stored in the Accumulator.
Operation	$ACC \leftarrow ACC + [m] + C$
Affected flag(s)	OV, Z, AC, C, SC
LADCM A,[m]	Add ACC to Data Memory with Carry
Description	The contents of the specified Data Memory, Accumulator and the carry flag are added. The result is stored in the specified Data Memory.
Operation	$[m] \leftarrow ACC + [m] + C$
Affected flag(s)	OV, Z, AC, C, SC
LADD A,[m]	Add Data Memory to ACC
Description	The contents of the specified Data Memory and the Accumulator are added. The result is stored in the Accumulator.
Operation	$ACC \leftarrow ACC + [m]$
Affected flag(s)	OV, Z, AC, C, SC
LADDM A,[m]	Add ACC to Data Memory
Description	The contents of the specified Data Memory and the Accumulator are added. The result is stored in the specified Data Memory.
Operation	$[m] \leftarrow ACC + [m]$
Affected flag(s)	OV, Z, AC, C, SC
LAND A,[m]	Logical AND Data Memory to ACC
Description	Data in the Accumulator and the specified Data Memory perform a bitwise logical AND operation. The result is stored in the Accumulator.
Operation	$ACC \leftarrow ACC \text{ "AND" } [m]$
Affected flag(s)	Z
LANDM A,[m]	Logical AND ACC to Data Memory
Description	Data in the specified Data Memory and the Accumulator perform a bitwise logical AND operation. The result is stored in the Data Memory.
Operation	$[m] \leftarrow ACC \text{ "AND" } [m]$
Affected flag(s)	Z
LCLR [m]	Clear Data Memory
Description	Each bit of the specified Data Memory is cleared to 0.
Operation	$[m] \leftarrow 00H$
Affected flag(s)	None
LCLR [m].i	Clear bit of Data Memory
Description	Bit i of the specified Data Memory is cleared to 0.
Operation	$[m].i \leftarrow 0$
Affected flag(s)	None

LCPL [m]	Complement Data Memory
Description	Each bit of the specified Data Memory is logically complemented (1's complement). Bits which previously contained a 1 are changed to 0 and vice versa.
Operation	$[m] \leftarrow \overline{[m]}$
Affected flag(s)	Z
LCPLA [m]	Complement Data Memory with result in ACC
Description	Each bit of the specified Data Memory is logically complemented (1's complement). Bits which previously contained a 1 are changed to 0 and vice versa. The complemented result is stored in the Accumulator and the contents of the Data Memory remain unchanged.
Operation	$ACC \leftarrow \overline{[m]}$
Affected flag(s)	Z
LDAA [m]	Decimal-Adjust ACC for addition with result in Data Memory
Description	Convert the contents of the Accumulator value to a BCD (Binary Coded Decimal) value resulting from the previous addition of two BCD variables. If the low nibble is greater than 9 or if AC flag is set, then a value of 6 will be added to the low nibble. Otherwise the low nibble remains unchanged. If the high nibble is greater than 9 or if the C flag is set, then a value of 6 will be added to the high nibble. Essentially, the decimal conversion is performed by adding 00H, 06H, 60H or 66H depending on the Accumulator and flag conditions. Only the C flag may be affected by this instruction which indicates that if the original BCD sum is greater than 100, it allows multiple precision decimal addition.
Operation	$[m] \leftarrow ACC + 00H$ or $[m] \leftarrow ACC + 06H$ or $[m] \leftarrow ACC + 60H$ or $[m] \leftarrow ACC + 66H$
Affected flag(s)	C
LDEC [m]	Decrement Data Memory
Description	Data in the specified Data Memory is decremented by 1.
Operation	$[m] \leftarrow [m] - 1$
Affected flag(s)	Z
LDECA [m]	Decrement Data Memory with result in ACC
Description	Data in the specified Data Memory is decremented by 1. The result is stored in the Accumulator. The contents of the Data Memory remain unchanged.
Operation	$ACC \leftarrow [m] - 1$
Affected flag(s)	Z
LINC [m]	Increment Data Memory
Description	Data in the specified Data Memory is incremented by 1.
Operation	$[m] \leftarrow [m] + 1$
Affected flag(s)	Z
LINCA [m]	Increment Data Memory with result in ACC
Description	Data in the specified Data Memory is incremented by 1. The result is stored in the Accumulator. The contents of the Data Memory remain unchanged.
Operation	$ACC \leftarrow [m] + 1$
Affected flag(s)	Z

LMOV A,[m]	Move Data Memory to ACC
Description	The contents of the specified Data Memory are copied to the Accumulator.
Operation	$ACC \leftarrow [m]$
Affected flag(s)	None
LMOV [m],A	Move ACC to Data Memory
Description	The contents of the Accumulator are copied to the specified Data Memory.
Operation	$[m] \leftarrow ACC$
Affected flag(s)	None
LOR A,[m]	Logical OR Data Memory to ACC
Description	Data in the Accumulator and the specified Data Memory perform a bitwise logical OR operation. The result is stored in the Accumulator.
Operation	$ACC \leftarrow ACC \text{ "OR" } [m]$
Affected flag(s)	Z
LORM A,[m]	Logical OR ACC to Data Memory
Description	Data in the specified Data Memory and the Accumulator perform a bitwise logical OR operation. The result is stored in the Data Memory.
Operation	$[m] \leftarrow ACC \text{ "OR" } [m]$
Affected flag(s)	Z
LRL [m]	Rotate Data Memory left
Description	The contents of the specified Data Memory are rotated left by 1 bit with bit 7 rotated into bit 0.
Operation	$[m].(i+1) \leftarrow [m].i; (i=0\sim6)$ $[m].0 \leftarrow [m].7$
Affected flag(s)	None
LRLA [m]	Rotate Data Memory left with result in ACC
Description	The contents of the specified Data Memory are rotated left by 1 bit with bit 7 rotated into bit 0. The rotated result is stored in the Accumulator and the contents of the Data Memory remain unchanged.
Operation	$ACC.(i+1) \leftarrow [m].i; (i=0\sim6)$ $ACC.0 \leftarrow [m].7$
Affected flag(s)	None
LRLC [m]	Rotate Data Memory left through Carry
Description	The contents of the specified Data Memory and the carry flag are rotated left by 1 bit. Bit 7 replaces the Carry bit and the original carry flag is rotated into bit 0.
Operation	$[m].(i+1) \leftarrow [m].i; (i=0\sim6)$ $[m].0 \leftarrow C$ $C \leftarrow [m].7$
Affected flag(s)	C
LRLCA [m]	Rotate Data Memory left through Carry with result in ACC
Description	Data in the specified Data Memory and the carry flag are rotated left by 1 bit. Bit 7 replaces the Carry bit and the original carry flag is rotated into the bit 0. The rotated result is stored in the Accumulator and the contents of the Data Memory remain unchanged.
Operation	$ACC.(i+1) \leftarrow [m].i; (i=0\sim6)$ $ACC.0 \leftarrow C$ $C \leftarrow [m].7$
Affected flag(s)	C

LRR [m]	Rotate Data Memory right
Description	The contents of the specified Data Memory are rotated right by 1 bit with bit 0 rotated into bit 7.
Operation	$[m].i \leftarrow [m].(i+1); (i=0\sim6)$ $[m].7 \leftarrow [m].0$
Affected flag(s)	None
LRRRA [m]	Rotate Data Memory right with result in ACC
Description	Data in the specified Data Memory is rotated right by 1 bit with bit 0 rotated into bit 7. The rotated result is stored in the Accumulator and the contents of the Data Memory remain unchanged.
Operation	$ACC.i \leftarrow [m].(i+1); (i=0\sim6)$ $ACC.7 \leftarrow [m].0$
Affected flag(s)	None
LRRC [m]	Rotate Data Memory right through Carry
Description	The contents of the specified Data Memory and the carry flag are rotated right by 1 bit. Bit 0 replaces the Carry bit and the original carry flag is rotated into bit 7.
Operation	$[m].i \leftarrow [m].(i+1); (i=0\sim6)$ $[m].7 \leftarrow C$ $C \leftarrow [m].0$
Affected flag(s)	C
LRRCA [m]	Rotate Data Memory right through Carry with result in ACC
Description	Data in the specified Data Memory and the carry flag are rotated right by 1 bit. Bit 0 replaces the Carry bit and the original carry flag is rotated into bit 7. The rotated result is stored in the Accumulator and the contents of the Data Memory remain unchanged.
Operation	$ACC.i \leftarrow [m].(i+1); (i=0\sim6)$ $ACC.7 \leftarrow C$ $C \leftarrow [m].0$
Affected flag(s)	C
LSBC A,[m]	Subtract Data Memory from ACC with Carry
Description	The contents of the specified Data Memory and the complement of the carry flag are subtracted from the Accumulator. The result is stored in the Accumulator. Note that if the result of subtraction is negative, the C flag will be cleared to 0, otherwise if the result is positive or zero, the C flag will be set to 1.
Operation	$ACC \leftarrow ACC - [m] - \bar{C}$
Affected flag(s)	OV, Z, AC, C, SC, CZ
LSBCM A,[m]	Subtract Data Memory from ACC with Carry and result in Data Memory
Description	The contents of the specified Data Memory and the complement of the carry flag are subtracted from the Accumulator. The result is stored in the Data Memory. Note that if the result of subtraction is negative, the C flag will be cleared to 0, otherwise if the result is positive or zero, the C flag will be set to 1.
Operation	$[m] \leftarrow ACC - [m] - \bar{C}$
Affected flag(s)	OV, Z, AC, C, SC, CZ

LSDZ [m]	Skip if decrement Data Memory is 0
Description	The contents of the specified Data Memory are first decremented by 1. If the result is 0 the following instruction is skipped. As this requires the insertion of a dummy instruction while the next instruction is fetched, it is a three cycle instruction. If the result is not 0 the program proceeds with the following instruction.
Operation	$[m] \leftarrow [m] - 1$ Skip if $[m]=0$
Affected flag(s)	None
LSDZA [m]	Skip if decrement Data Memory is zero with result in ACC
Description	The contents of the specified Data Memory are first decremented by 1. If the result is 0, the following instruction is skipped. The result is stored in the Accumulator but the specified Data Memory contents remain unchanged. As this requires the insertion of a dummy instruction while the next instruction is fetched, it is a three cycle instruction. If the result is not 0, the program proceeds with the following instruction.
Operation	$ACC \leftarrow [m] - 1$ Skip if $ACC=0$
Affected flag(s)	None
LSET [m]	Set Data Memory
Description	Each bit of the specified Data Memory is set to 1.
Operation	$[m] \leftarrow FFH$
Affected flag(s)	None
LSET [m].i	Set bit of Data Memory
Description	Bit i of the specified Data Memory is set to 1.
Operation	$[m].i \leftarrow 1$
Affected flag(s)	None
LSIZ [m]	Skip if increment Data Memory is 0
Description	The contents of the specified Data Memory are first incremented by 1. If the result is 0, the following instruction is skipped. As this requires the insertion of a dummy instruction while the next instruction is fetched, it is a three cycle instruction. If the result is not 0 the program proceeds with the following instruction.
Operation	$[m] \leftarrow [m] + 1$ Skip if $[m]=0$
Affected flag(s)	None
LSIZA [m]	Skip if increment Data Memory is zero with result in ACC
Description	The contents of the specified Data Memory are first incremented by 1. If the result is 0, the following instruction is skipped. The result is stored in the Accumulator but the specified Data Memory contents remain unchanged. As this requires the insertion of a dummy instruction while the next instruction is fetched, it is a three cycle instruction. If the result is not 0 the program proceeds with the following instruction.
Operation	$ACC \leftarrow [m] + 1$ Skip if $ACC=0$
Affected flag(s)	None
LSNZ [m].i	Skip if bit i of Data Memory is not 0
Description	If bit i of the specified Data Memory is not 0, the following instruction is skipped. As this requires the insertion of a dummy instruction while the next instruction is fetched, it is a three cycle instruction. If the result is 0 the program proceeds with the following instruction.
Operation	Skip if $[m].i \neq 0$
Affected flag(s)	None

LSNZ [m]	Skip if Data Memory is not 0
Description	The contents of the specified Data Memory are read out and then written to the specified Data Memory again. If the content of the specified Data Memory is not 0, the following instruction is skipped. As this requires the insertion of a dummy instruction while the next instruction is fetched, it is a three cycle instruction. If the result is 0 the program proceeds with the following instruction.
Operation	Skip if [m] ≠ 0
Affected flag(s)	None
LSUB A,[m]	Subtract Data Memory from ACC
Description	The specified Data Memory is subtracted from the contents of the Accumulator. The result is stored in the Accumulator. Note that if the result of subtraction is negative, the C flag will be cleared to 0, otherwise if the result is positive or zero, the C flag will be set to 1.
Operation	ACC ← ACC – [m]
Affected flag(s)	OV, Z, AC, C, SC, CZ
LSUBM A,[m]	Subtract Data Memory from ACC with result in Data Memory
Description	The specified Data Memory is subtracted from the contents of the Accumulator. The result is stored in the Data Memory. Note that if the result of subtraction is negative, the C flag will be cleared to 0, otherwise if the result is positive or zero, the C flag will be set to 1.
Operation	[m] ← ACC – [m]
Affected flag(s)	OV, Z, AC, C, SC, CZ
LSWAP [m]	Swap nibbles of Data Memory
Description	The low-order and high-order nibbles of the specified Data Memory are interchanged.
Operation	[m].3~[m].0 ↔ [m].7~[m].4
Affected flag(s)	None
LSWAPA [m]	Swap nibbles of Data Memory with result in ACC
Description	The low-order and high-order nibbles of the specified Data Memory are interchanged. The result is stored in the Accumulator. The contents of the Data Memory remain unchanged.
Operation	ACC.3~ACC.0 ← [m].7~[m].4 ACC.7~ACC.4 ← [m].3~[m].0
Affected flag(s)	None
LSZ [m]	Skip if Data Memory is 0
Description	The contents of the specified Data Memory are read out and then written to the specified Data Memory again. If the contents of the specified Data Memory is 0, the following instruction is skipped. As this requires the insertion of a dummy instruction while the next instruction is fetched, it is a three cycle instruction. If the result is not 0 the program proceeds with the following instruction.
Operation	Skip if [m]=0
Affected flag(s)	None
LSZA [m]	Skip if Data Memory is 0 with data movement to ACC
Description	The contents of the specified Data Memory are copied to the Accumulator. If the value is zero, the following instruction is skipped. As this requires the insertion of a dummy instruction while the next instruction is fetched, it is a three cycle instruction. If the result is not 0 the program proceeds with the following instruction.
Operation	ACC ← [m] Skip if [m]=0
Affected flag(s)	None

LSZ [m].i	Skip if bit i of Data Memory is 0
Description	If bit i of the specified Data Memory is 0, the following instruction is skipped. As this requires the insertion of a dummy instruction while the next instruction is fetched, it is a three cycle instruction. If the result is not 0, the program proceeds with the following instruction.
Operation	Skip if [m].i=0
Affected flag(s)	None
LTABRD [m]	Read table (specific page) to TBLH and Data Memory
Description	The low byte of the program code (specific page) addressed by the table pointer (TBHP and TBLP) is moved to the specified Data Memory and the high byte moved to TBLH.
Operation	[m] ← program code (low byte) TBLH ← program code (high byte)
Affected flag(s)	None
LTABRDL [m]	Read table (last page) to TBLH and Data Memory
Description	The low byte of the program code (last page) addressed by the table pointer (TBLP) is moved to the specified Data Memory and the high byte moved to TBLH.
Operation	[m] ← program code (low byte) TBLH ← program code (high byte)
Affected flag(s)	None
LITABRD [m]	Increment table pointer low byte first and read table (specific page) to TBLH and Data Memory
Description	Increment table pointer low byte, TBLP, first and then the program code (specific page) addressed by the table pointer (TBHP and TBLP) is moved to the specified Data Memory and the high byte moved to TBLH.
Operation	[m] ← program code (low byte) TBLH ← program code (high byte)
Affected flag(s)	None
LITABRDL [m]	Increment table pointer low byte first and read table (last page) to TBLH and Data Memory
Description	Increment table pointer low byte, TBLP, first and then the low byte of the program code (last page) addressed by the table pointer (TBLP) is moved to the specified Data Memory and the high byte moved to TBLH.
Operation	[m] ← program code (low byte) TBLH ← program code (high byte)
Affected flag(s)	None
LXOR A,[m]	Logical XOR Data Memory to ACC
Description	Data in the Accumulator and the specified Data Memory perform a bitwise logical XOR operation. The result is stored in the Accumulator.
Operation	ACC ← ACC "XOR" [m]
Affected flag(s)	Z
LXORM A,[m]	Logical XOR ACC to Data Memory
Description	Data in the specified Data Memory and the Accumulator perform a bitwise logical XOR operation. The result is stored in the Data Memory.
Operation	[m] ← ACC "XOR" [m]
Affected flag(s)	Z

Package Information

Note that the package information provided here is for consultation purposes only. As this information may be updated at regular intervals users are reminded to consult the [Holtek website](#) for the latest version of the [Package/Carton Information](#).

Additional supplementary information with regard to packaging is listed below. Click on the relevant section to be transferred to the relevant website page.

- Package Information (include Outline Dimensions, Product Tape and Reel Specifications)
- The Operation Instruction of Packing Materials
- Carton information

24-pin SOP (300mil) Outline Dimensions

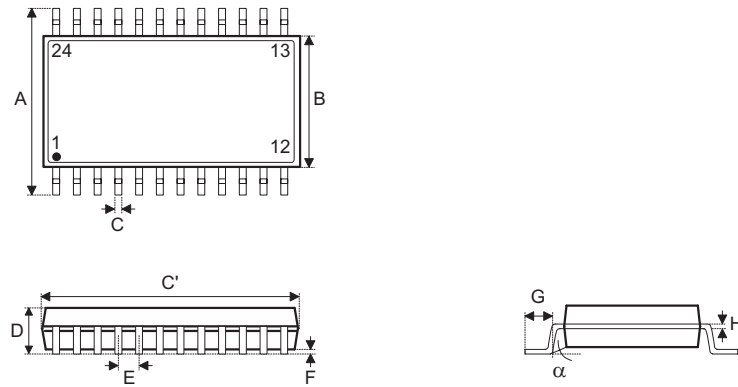

Symbol	Dimensions in inch		
	Min.	Nom.	Max.
A	—	0.406 BSC	—
B	—	0.295 BSC	—
C	0.012	—	0.020
C'	—	0.606 BSC	—
D	—	—	0.104
E	—	0.050 BSC	—
F	0.004	—	0.012
G	0.016	—	0.050
H	0.008	—	0.013
α	0°	—	8°

Symbol	Dimensions in mm		
	Min.	Nom.	Max.
A	—	10.30 BSC	—
B	—	7.50 BSC	—
C	0.31	—	0.51
C'	—	15.40 BSC	—
D	—	—	2.65
E	—	1.27 BSC	—
F	0.10	—	0.30
G	0.40	—	1.27
H	0.20	—	0.33
α	0°	—	8°

24-pin SSOP (150mil) Outline Dimensions

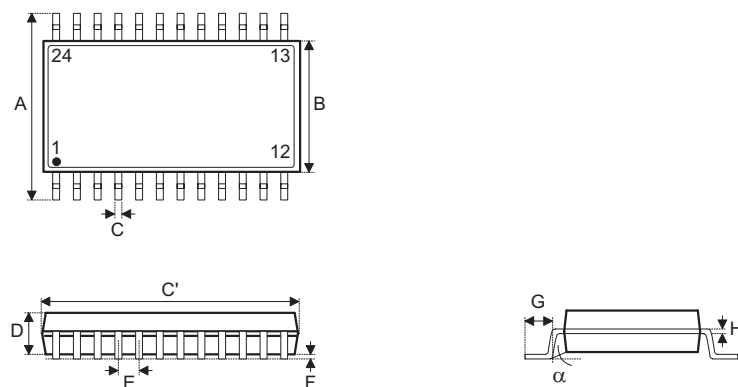

Symbol	Dimensions in inch		
	Min.	Nom.	Max.
A	—	0.236 BSC	—
B	—	0.154 BSC	—
C	0.008	—	0.012
C'	—	0.341 BSC	—
D	—	—	0.069
E	—	0.025 BSC	—
F	0.004	—	0.010
G	0.016	—	0.050
H	0.004	—	0.010
α	0°	—	8°

Symbol	Dimensions in mm		
	Min.	Nom.	Max.
A	—	6.00 BSC	—
B	—	3.90 BSC	—
C	0.20	—	0.30
C'	—	8.66 BSC	—
D	—	—	1.75
E	—	0.635 BSC	—
F	0.10	—	0.25
G	0.41	—	1.27
H	0.10	—	0.25
α	0°	—	8°

28-pin SOP (300mil) Outline Dimensions

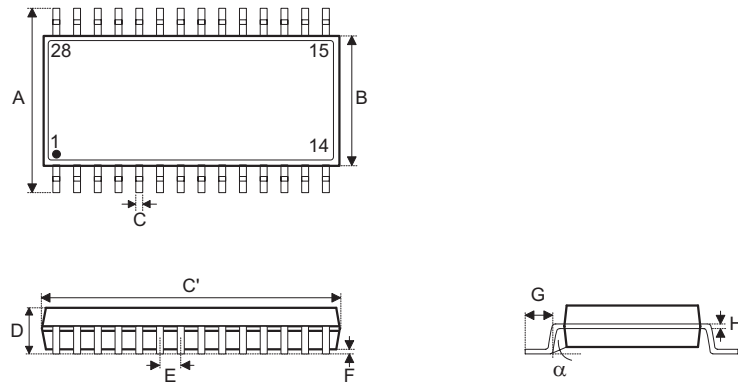

Symbol	Dimensions in inch		
	Min.	Nom.	Max.
A	—	0.406 BSC	—
B	—	0.295 BSC	—
C	0.012	—	0.020
C'	—	0.705 BSC	—
D	—	—	0.104
E	—	0.050 BSC	—
F	0.004	—	0.012
G	0.016	—	0.050
H	0.008	—	0.013
α	0°	—	8°

Symbol	Dimensions in mm		
	Min.	Nom.	Max.
A	—	10.30 BSC	—
B	—	7.50 BSC	—
C	0.31	—	0.51
C'	—	17.90 BSC	—
D	—	—	2.65
E	—	1.27 BSC	—
F	0.10	—	0.30
G	0.40	—	1.27
H	0.20	—	0.33
α	0°	—	8°

28-pin SSOP (150mil) Outline Dimensions

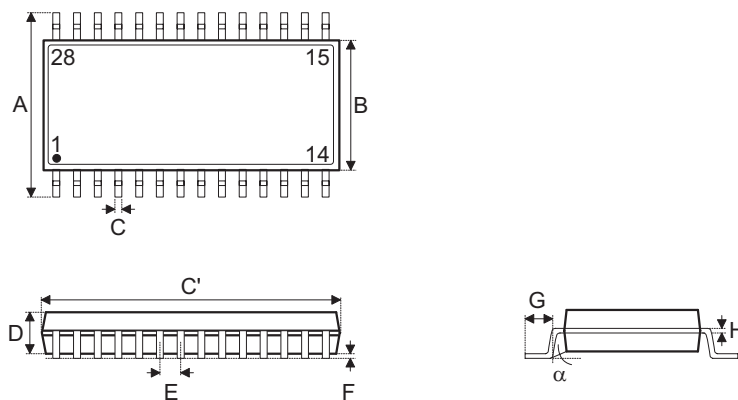

Symbol	Dimensions in inch		
	Min.	Nom.	Max.
A	—	0.236 BSC	—
B	—	0.154 BSC	—
C	0.008	—	0.012
C'	—	0.390 BSC	—
D	—	—	0.069
E	—	0.025 BSC	—
F	0.004	—	0.010
G	0.016	—	0.050
H	0.004	—	0.010
α	0°	—	8°

Symbol	Dimensions in mm		
	Min.	Nom.	Max.
A	—	6.00 BSC	—
B	—	3.90 BSC	—
C	0.20	—	0.30
C'	—	9.90 BSC	—
D	—	—	1.75
E	—	0.635 BSC	—
F	0.10	—	0.25
G	0.41	—	1.27
H	0.10	—	0.25
α	0°	—	8°

44-pin LQFP (10mm×10mm) (FP2.0mm) Outline Dimensions

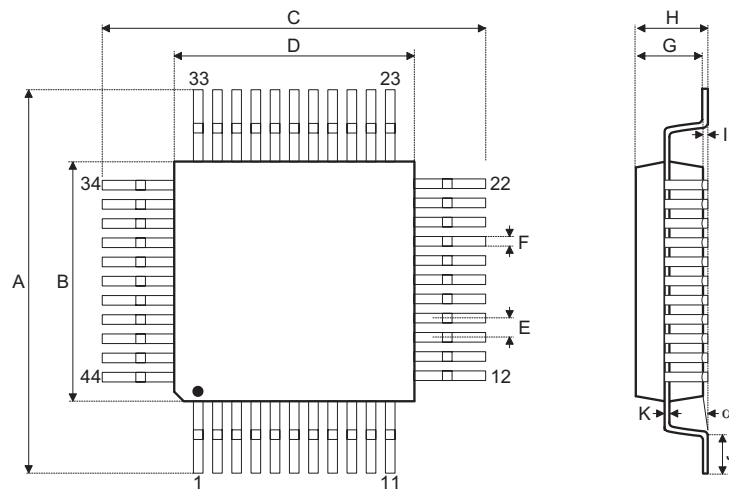

Symbol	Dimensions in inch		
	Min.	Nom.	Max.
A	—	0.472 BSC	—
B	—	0.394 BSC	—
C	—	0.472 BSC	—
D	—	0.394 BSC	—
E	—	0.032 BSC	—
F	0.012	0.015	0.018
G	0.053	0.055	0.057
H	—	—	0.063
I	0.002	—	0.006
J	0.018	0.024	0.030
K	0.004	—	0.008
α	0°	—	7°

Symbol	Dimensions in mm		
	Min.	Nom.	Max.
A	—	12.00 BSC	—
B	—	10.00 BSC	—
C	—	12.00 BSC	—
D	—	10.00 BSC	—
E	—	0.80 BSC	—
F	0.30	0.37	0.45
G	1.35	1.40	1.45
H	—	—	1.60
I	0.05	—	0.15
J	0.45	0.60	0.75
K	0.09	—	0.20
α	0°	—	7°

Copyright© 2022 by HOLTEK SEMICONDUCTOR INC. All Rights Reserved.

The information provided in this document has been produced with reasonable care and attention before publication, however, HOLTEK does not guarantee that the information is completely accurate. The information contained in this publication is provided for reference only and may be superseded by updates. HOLTEK disclaims any expressed, implied or statutory warranties, including but not limited to suitability for commercialization, satisfactory quality, specifications, characteristics, functions, fitness for a particular purpose, and non-infringement of any third-party's rights. HOLTEK disclaims all liability arising from the information and its application. In addition, HOLTEK does not recommend the use of HOLTEK's products where there is a risk of personal hazard due to malfunction or other reasons. HOLTEK hereby declares that it does not authorize the use of these products in life-saving, life-sustaining or safety critical components. Any use of HOLTEK's products in life-saving/sustaining or safety applications is entirely at the buyer's risk, and the buyer agrees to defend, indemnify and hold HOLTEK harmless from any damages, claims, suits, or expenses resulting from such use. The information provided in this document, including but not limited to the content, data, examples, materials, graphs, and trademarks, is the intellectual property of HOLTEK (and its licensors, where applicable) and is protected by copyright law and other intellectual property laws. No license, express or implied, to any intellectual property right, is granted by HOLTEK herein. HOLTEK reserves the right to revise the information described in the document at any time without prior notice. For the latest information, please contact us.