



HT32F65440A_MCU Board Hardware Description

Revision: V1.00 Date: April 18, 2024

www.holtek.com

Table of Contents

1. General Description	3
2. Schematics	6
2-1 HT32F65440A Peripheral Component Reference Circuit.....	6
2-2 Inverter Circuit.....	7
2-3 Over Current Protection Circuit and Current Sensing Circuit.....	8
2-4 MOSFET Temperature Feedback Circuit.....	8
2-5 DC Bus Voltage Feedback Circuit.....	9
2-6 Hall Sensor Feedback Circuit.....	10
2-7 VR Variable Resistor Circuit.....	10
2-8 Sensorless and Hall Sensor Jumper Settings.....	10
2-9 Programming Interface and Motor Workshop Communication.....	11
2-10 VCC Buck Resistors.....	13
2-11 Back EMF Detection Circuit.....	13
2-12 RF Receiver Module.....	14
2-13 MCU Standby and Wake-up Function.....	14
2-14 FG Speed Function.....	15
2-15 PWM Command Function.....	15
2-16 MCU Pin Function Definition.....	16
3. PCB Layout	17
4. BOM List	20

1. General Description

The HT32F65440A_MCU Board and the HT32 BLDC Motor P/N MOS Power Board are shown below. (1) MOSFET inverter. (2) VM & VCC capacitors and 5V LDO output. (3) Over current comparator input low-pass filter capacitors. (4) Hall sensor connection ports. (5) VR variable resistor. (6) Reset button. (7) SWD programming interface. (8) VCC buck resistors. (9) HT32F65440A MCU. (10) MOSFET temperature feedback circuit. (11) RF receiver module. (12) External PWM command signal receiving circuit. (13) FG speed signal circuit. (14) MCU wake-up circuit. (15) Jumper to choose Hall sensor or sensorless. (16) Motor workshop communication interface. (17) Jumper to choose NTC or RF. (18) Jumper to choose MCU sleep mode, default hardware is in operation mode.

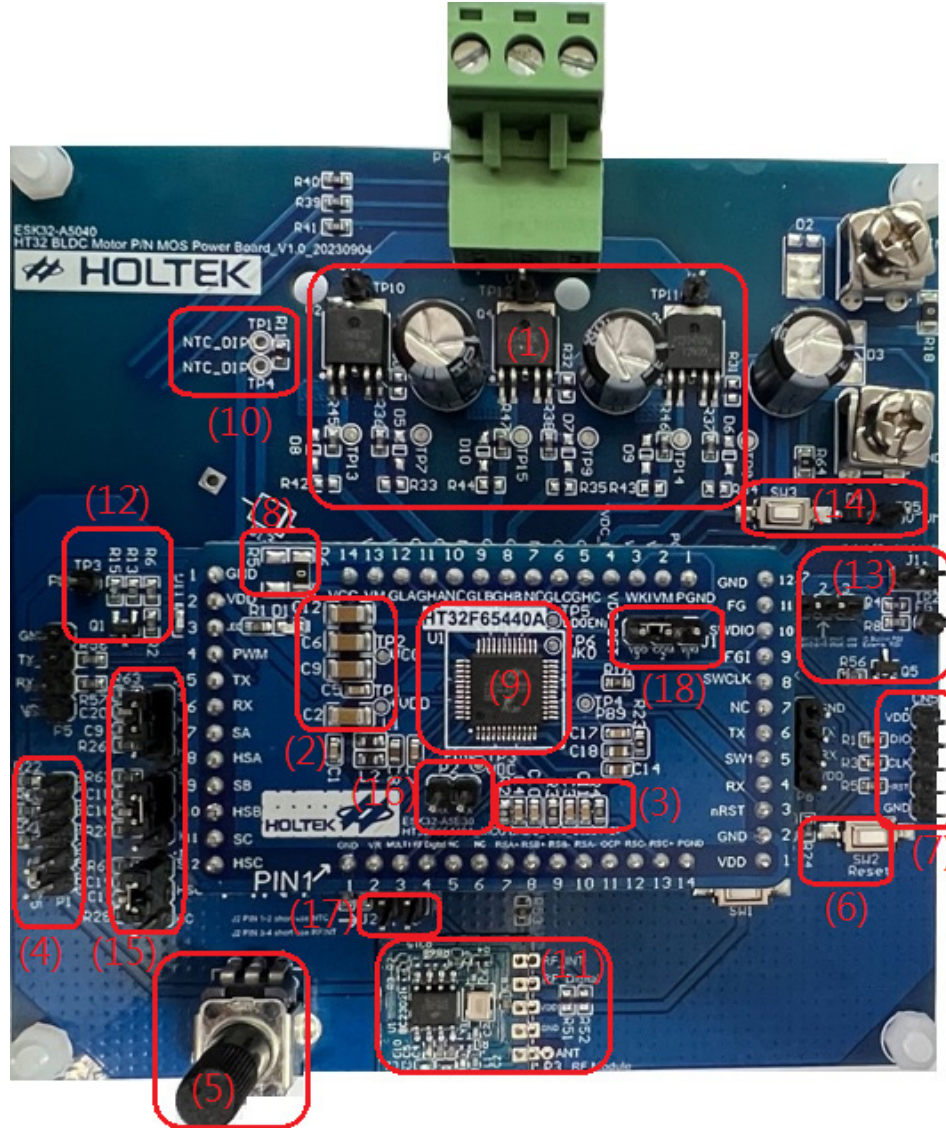

BLDC Motor Workshop HT32F65440A_MCU Board and HT32 BLDC Motor P/N MOS Power Board Front View

The HT32 BLDC Motor P/N MOS Power Board back view is shown below. J8 is shorted to J9 and J11 is shorted to J12. R54 is 0Ω, i.e. the HT32F65440A 2-shunt resistor connection, as show in the framed part (19) below.

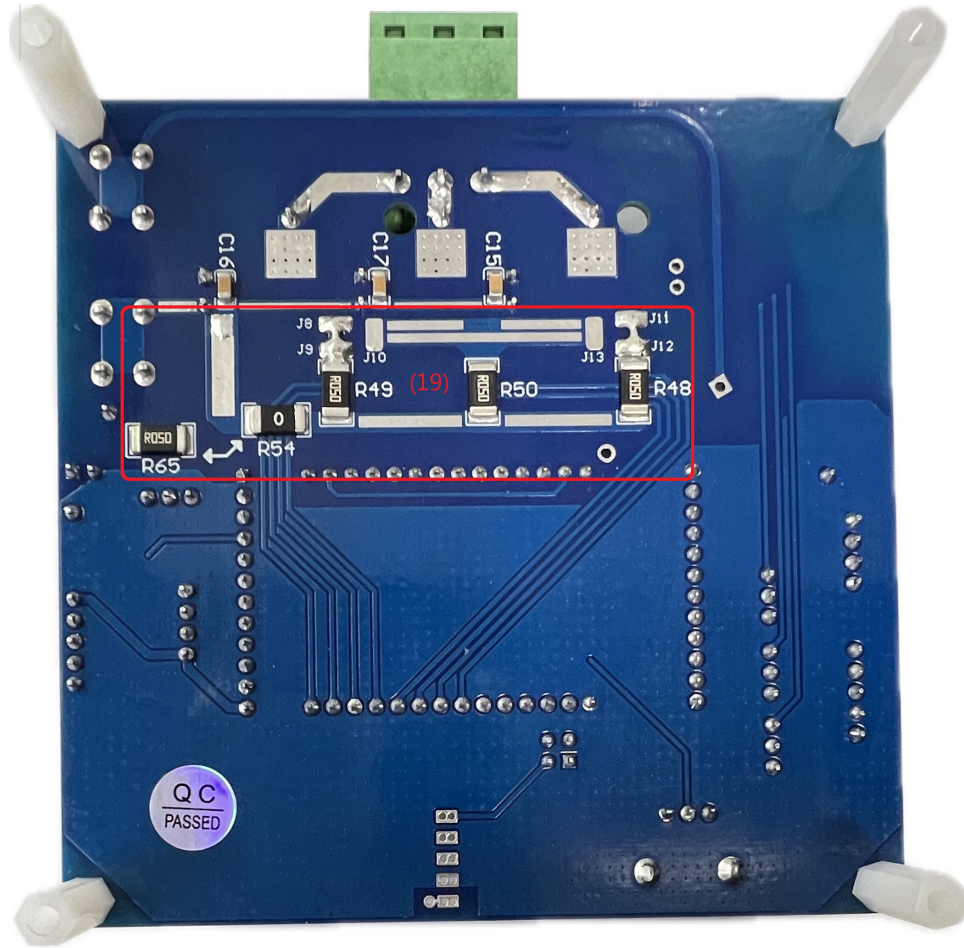

BLDC Motor Workshop HT32 BLDC Motor P/N MOS Power Board Back View

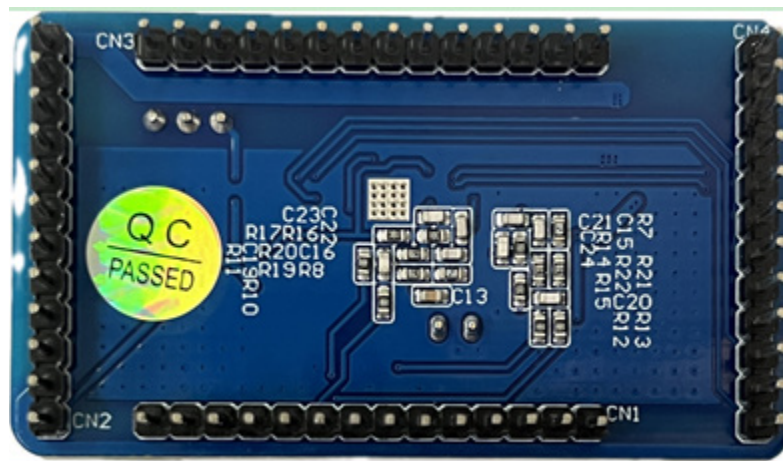

BLDC Motor Workshop HT32F65440A_MCU Board Back View

The figure below shows the HT32F65440A_MCU Board development environment. Users should connect the PC USB port to the e-Link32 Pro using a Mini USB cable, then connect the e-Link32 Pro to the HT32F65440A_MCU Board to communicate with the BLDC motor workshop. The input voltage range is DC 10V~32V.

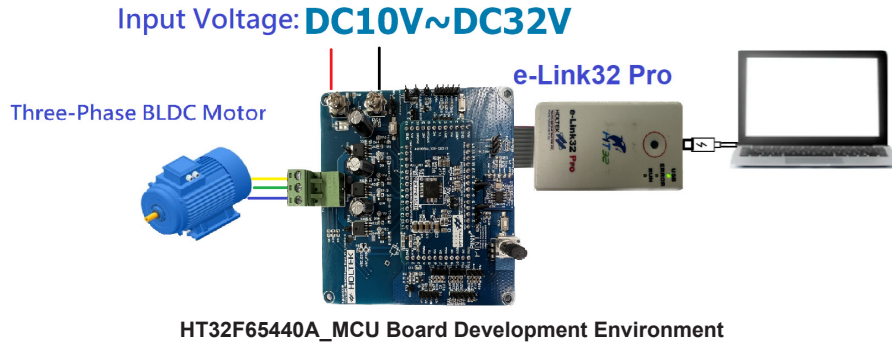

Features

- Input voltage: DC 10V~32V
- Max. DC Bus current: 2A
- Max. motor phase current: ±6.667A
- R_Shunt (Phase): 0.05Ω/2512/1%/2W
- DC Bus voltage divider ratio: 1/8.00
- Gate-Driver Polarity
 - (1) Low side active low
 - (2) High side active high

As the above feature shows, the HT32F65440A_MCU Board maximum motor phase current is ±6.667A. The following figure shows the OPA circuit of the phase current sampling. The default hardware parameters are shown as follows:

1. HT32 BLDC Motor P/N MOS Power Board R48, R49 and R50 specifications are all 0.05Ω/2512/±1%/2W.
2. HT32F65440A_MCU Board R10, R11, R12 and R13 specifications are all 180Ω.
3. HT32F65440A_MCU Board R19, R20, R21 and R22 specifications are all 820Ω.
4. HT32F65440A_MCU Board R7 and R8 specifications are both 7.5KΩ.
5. HT32F65440A_MCU Board R14, R15, R16 and R17 specifications are all 15KΩ.

Under these hardware parameters, the maximum motor phase current is:

$$I_{max} = \frac{2.5V}{R_{shunt} \times OPA\ Gain} = \frac{2.5V}{0.05\Omega \times 7.5} = 6.667A$$

When designing the magnification and R-Shunt, it is necessary to pay attention to the motor phase current range, which can not be larger than its maximum sampling value. If the motor phase current range is too wide, the sampling resolution will be affected.

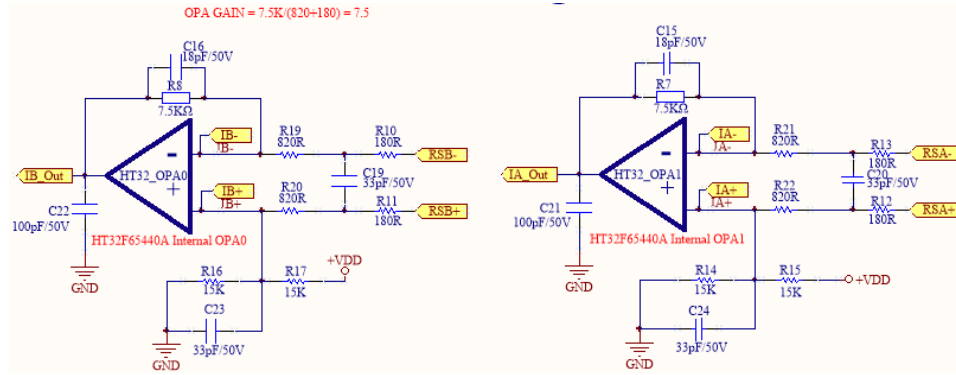

OPA Circuit of Phase Current Sampling

2. Schematics

This chapter will present the schematics and explain the HT32F65440A MCU Board and the HT32 BLDC Motor P/N MOS Power Board hardware circuit as shown in sections from 2-1 to 2-16.

2-1 HT32F65440A Peripheral Component Reference Circuit

The following figure shows the HT32F65440A peripheral component reference circuit which uses a P-N driver with an integrated 12V gate-clamping voltage. The integrated 5V LDO can supply power for the MCU circuit. The driver provides a 350mA source current and a 700mA drain current. It also contains the over temperature protection, the VCC under voltage protection and the 5V LDO under voltage protection.

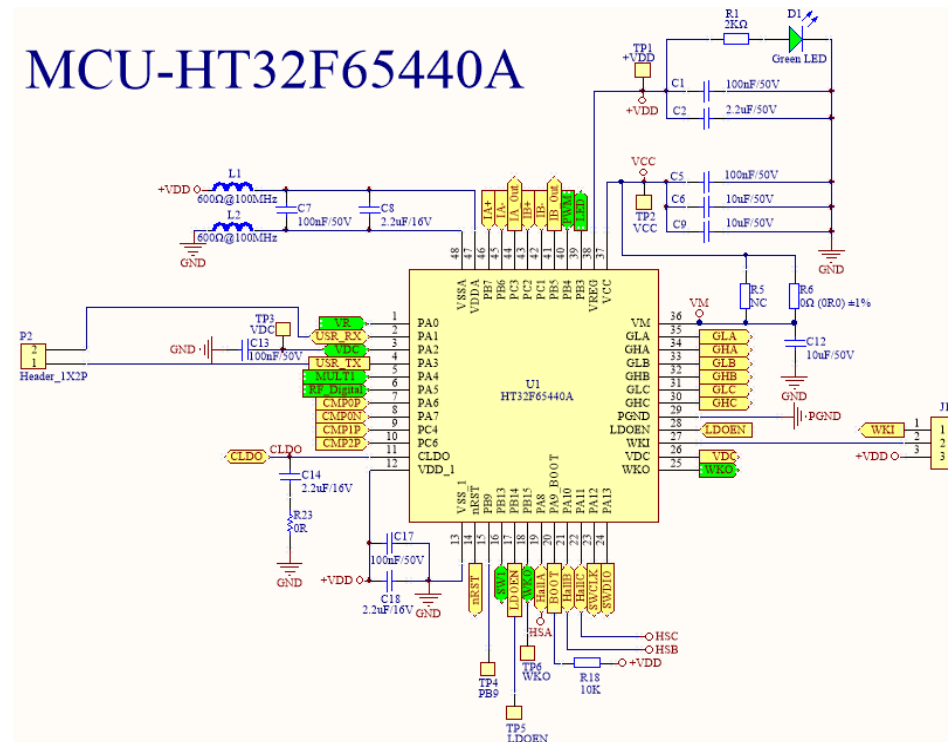

HT32F65440A Peripheral Component Reference Circuit

2-2 Inverter Circuit

The figure below shows the inverter circuit, its switching component model is P2204ND5G and the specifications are shown in the first table below. The MOSFET driving ability can be adjusted by the rise and fall time of the gate resistor and diode. The Shunt resistors are used to feedback motor phase current signals amplified by the internal OPA to the MCU for FOC closed-loop control. The hardware default value of these resistors are 0.05Ω/2512/1%/2W. Users should pay attention that the resistance rated power should be more than 2W if want to change the resistance.

The HT32F65440A is a 2-shunt resistor control MCU. J8 should be shorted to J9 and J11 should be shorted to J12. R54 is 0Ω. As the upper MCU board is related to the settings of the current sampling resistor jumper on the lower board, the J8, J9, J10, J11, J12 and J13 jumpers are removed by default. Users determine these jumper settings on the lower board according to the upper MCU board selected, which can refer to the second table below.

Item	N-ch	P-ch
Vds	+40V	-40V
Rds(on).max @ VGS=10V	14mΩ	14mΩ
Id	50A	-50A
Qg	310nC	420nC

P2204ND5G Specifications

Upper MCU Board	Current Sampling Resistor Jumper Settings on the Lower Board	Bus Overcurrent Resistor
HT32F65x32A 1-shunt resistor control MCU	J8 short to J10 & J11 short to J13	R54=0Ω (default)
HT32F65x40A 2-shunt resistor control MCU	J8 short to J9 & J11 short to J12	R54=0Ω (default)
HT32F66x46A 3-shunt resistor control MCU	J8 short to J9 & J11 short to J12	R54=50mΩ (interchange with R65)

Current Sampling Resistor Jumper Settings on the Lower Board

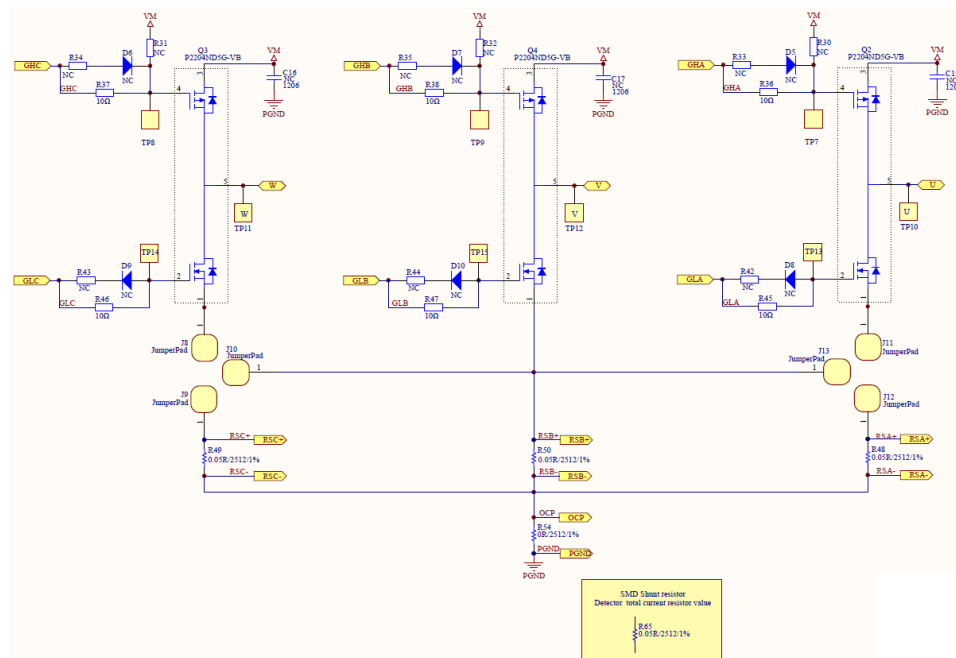

Inverter Circuit

2-3 Over Current Protection Circuit and Current Sensing Circuit

The figure below shows the over current protection circuit and current sensing circuit. Each voltage of the R-Shunt in the U/V/W phase passes through a low-pass filter respectively, then enters corresponding comparator. Each comparator is used to compare the filtered voltage with the internal DAC over current threshold to achieve the over current protection function.

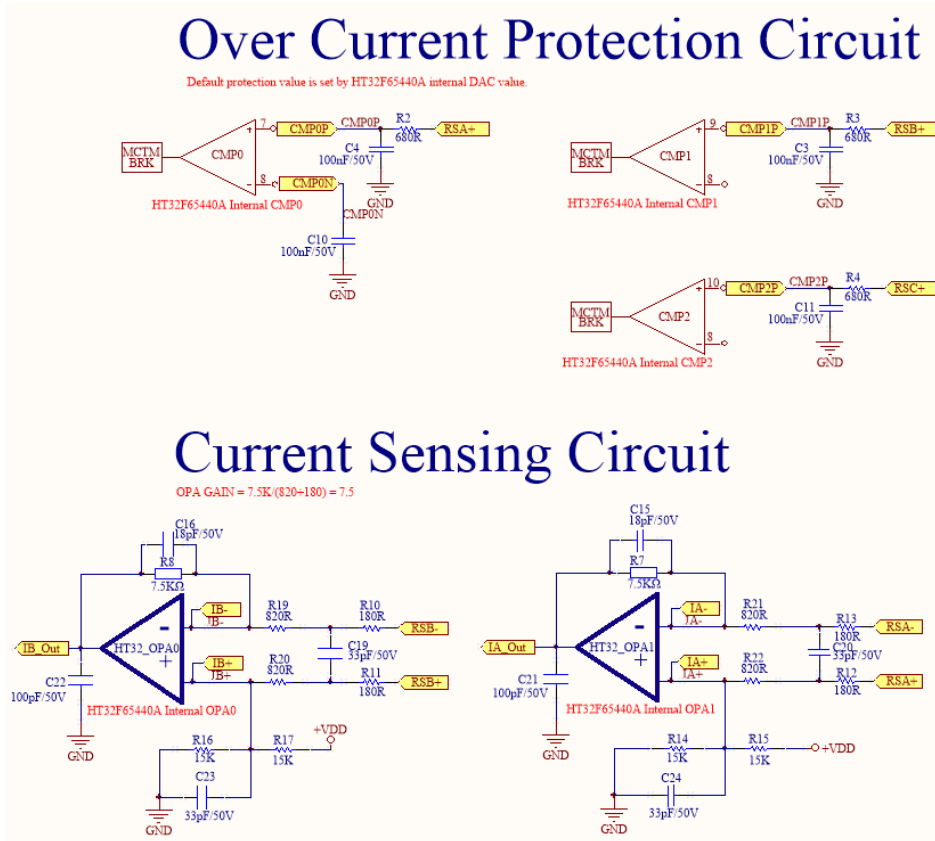

Over Current Protection Circuit and Current Sensing Circuit

2-4 MOSFET Temperature Feedback Circuit

The figure below shows the MOSFET temperature feedback circuit. The NTC component part number is NTCG163JF103FT1, which is a negative temperature coefficient resistor with a B value of $3380K \pm 1\%$. Users can read the signals by the MCU ADC to calculate the current NTC resistance, and then use the B value to calculate the current MOSFET temperature. The R11 footprint is SMD 0603. If the temperature function is required and the NTC needs to be as closed to the MOSFET heat source as possible, users can remove R11 and replace it with a plugin NTC resistor. The NTC will be closer to the heat source through its pins, and the NTC pins can be soldered to NTC_DIP vias.

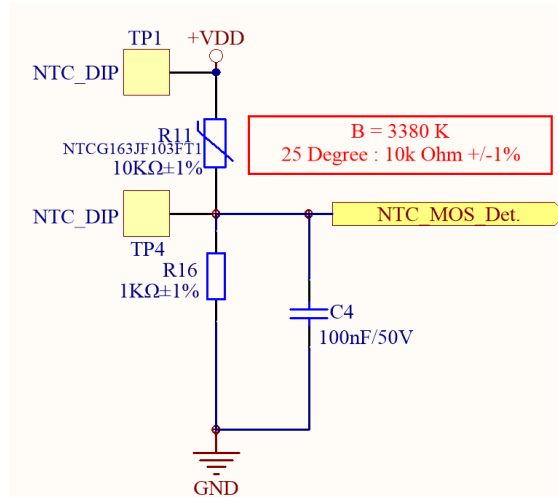

MOSFET Temperature Feedback Circuit



Actual Layout and NTC_DIP

2-5 DC Bus Voltage Feedback Circuit

The figure below shows the DC bus voltage feedback circuit. The ratio of the VDC_DET feedback signal and the actual DC bus voltage is 1/16. The current DC bus voltage can be calculated by the voltage read from the MCU and the hardware reduction ratio. This external circuit can be ignored since there is a DC bus voltage feedback circuit integrated within the HT32F65440A, the ratio of the internal feedback signal and the actual DC bus voltage is 1/8.

DC Bus Voltage Detection

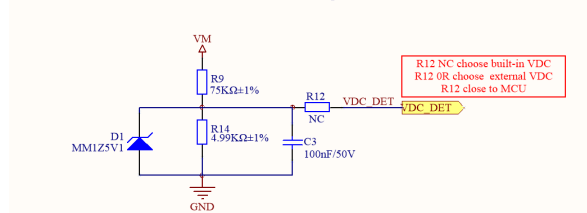

DC Bus Voltage Feedback Circuit

2-6 Hall Sensor Feedback Circuit

The figure below shows the Hall sensor feedback circuit. Connect three Hall signals to the pin3~pin5 of the P1 pin header if there are three Hall sensors used for the motor. Initially, the input Hall signals will be pulled to +VDD by pull-high resistors and then be passed to the low-pass filter. After that, the filtered signals are input to the MCU for phase change signal processing.

Hall Sensor Feedback Circuit

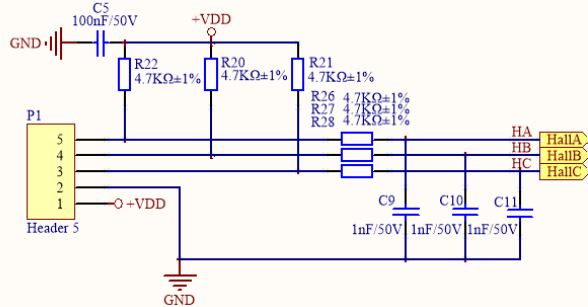

Hall Sensor Feedback Circuit

2-7 VR Variable Resistor Circuit

The figure below shows the VR variable resistor circuit. The VR divided voltage enters the MCU ADC after passing through a low-pass filter. For practical applications, this can be used as a motor speed command to achieve the human interface function.

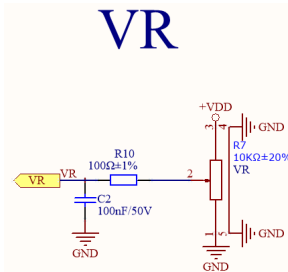

VR Variable Resistor Circuit

2-8 Sensorless and Hall Sensor Jumper Settings

The figure below shows the sensorless and Hall sensor jumper settings. When HallA, HallB and HallC signals are selected, short the pin2 to pin3 of the external J3, J5 and J6 jumpers. When SA, SB and SC signals are selected, short the pin1 to pin2 of the external J3, J5 and J6 jumpers. The hardware is sensorless by default.

Sensorless or Hall select

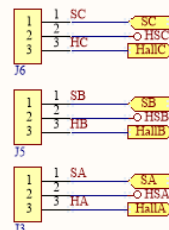

Sensorless and Hall Sensor Jumper Settings

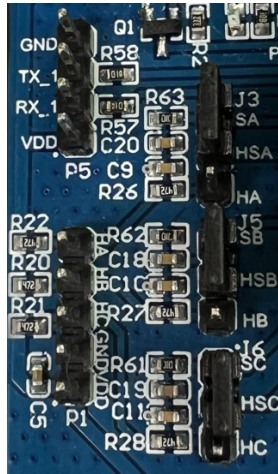

Actual Component Layout

2-9 Programming Interface and Motor Workshop Communication

Check whether the hardware pre-setting wiring of the HT32F65440A_MCU Board and the HT32 BLDC Motor P/N MOS Power Board are normal. As shown in the figures below, there are 4 places to be checked: (1) e-Link32 Pro programming wiring. (2) Input power wiring. (3) Motor wiring. (4) Current sampling resistor configuration, as shown in the second figure below. J8 should be shorted to J9 and J11 should be shorted to J12. R54 is 0Ω. If the bus contains an over current protection mechanism, the R54 resistance must be changed from 0Ω to 50mΩ, which can be interchanged with R65.

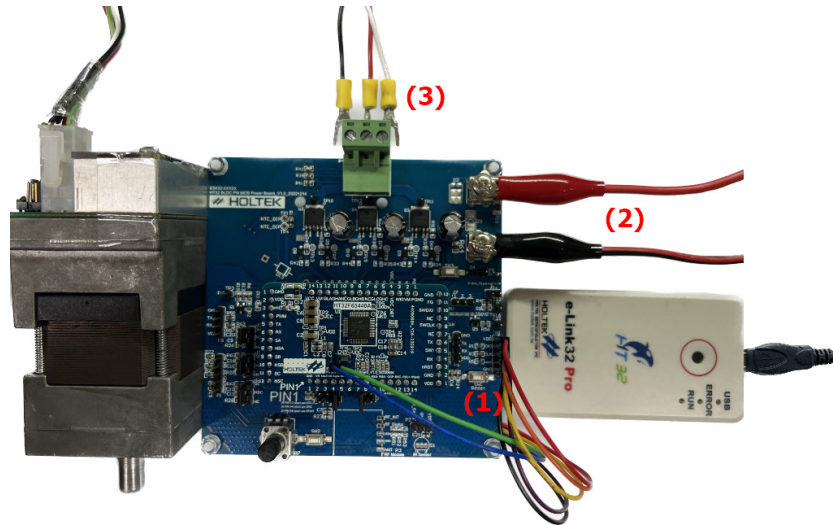

Check the HT32F65440A_MCU Board and the HT32 BLDC Motor P/N MOS Power Board Hardware Pre-setting Wiring

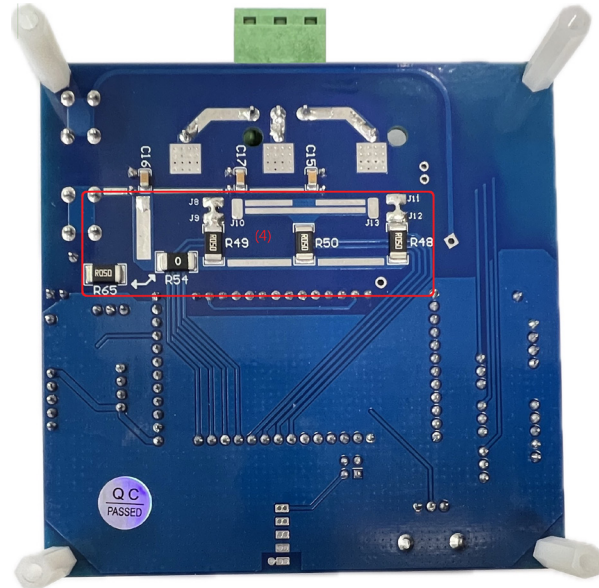

Check the HT32 BLDC Motor P/N MOS Power Board Current Sampling Resistor Setting

As shown in the first figure above, connect three-phase lines, black, red and white, of the square wave motor to the HT32 BLDC Motor P/N MOS Power Board terminals, U, V and W. Connect the e-Link32 Pro to the PC USB port using a Mini USB cable. Then, connect the e-Link32 Pro output port to the CN5 pin header of the HT32 BLDC Motor P/N MOS Power Board using Dupont lines, as shown in the following figures. The pins of the CN5 pin header from upper to lower are 5V (red), SWDIO (purple), SWCLK (orange), nRST (yellow) and GND (black). The e-Link32 Pro output pin7 and pin8, the VCOM_RXD and VCOM_TXD, are connected to the USR_TX (green) and USR_RX (blue) pins of the P2 pin header on the HT32F65440A_MCU Board respectively. Finally, connect the 24V power lines to DCIN and PGND screw terminals respectively.

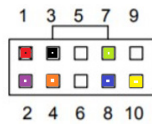

Pin#	Description	Pin#	Description
1	5V	2	SWDIO
3	GND	4	SWCLK
5	GND	6	Reserved
7	NC (VCOM_RXD ^(Note))	8	NC (VCOM_TXD ^(Note))
9	GND	10	Reset

e-Link32 Pro Output Port Definition

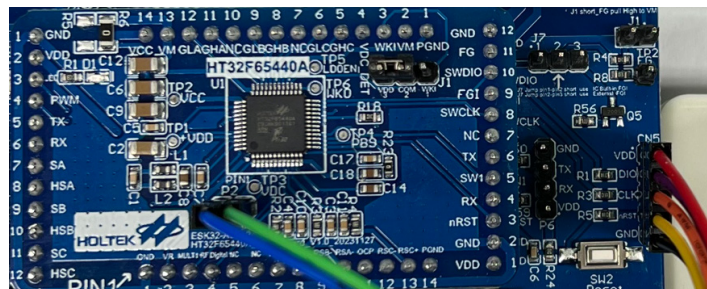

HT32F65440A_MCU Board P2 and HT32 BLDC Motor P/N MOS Power Board CN5 Corresponding Programming Cable Color Reference

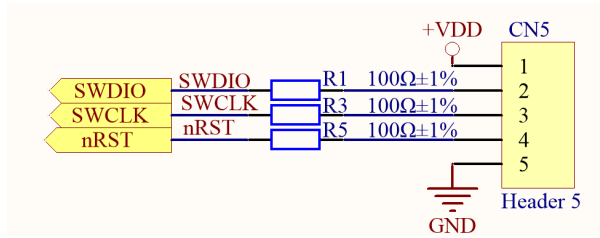

CN5 Pin Definition

2-10 VCC Buck Resistors

As shown in the figure below, R5 is NC and R6 is 0Ω by default, the resistor footprint is 1206. When the input voltage exceeds 24V, it is recommended to regulate R5 and R6 resistors to appropriate values to reduce the 5V LDO input voltage. The VCC current consumption is about 35mA under a normal operation. The resistor voltage can be calculated using Ohm’s law. It is recommended that the VCC operates at 12V~15V so that the device temperature can be controlled within a reasonable range.

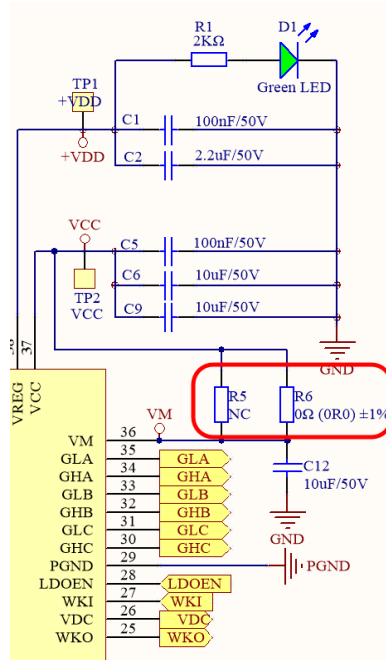

R5 and R6 Buck Resistors

2-11 Back EMF Detection Circuit

The figure below shows the back EMF detection circuit, which is used to detect the motor phase voltage. It is recommended that the divided voltage should not exceed 4V. The resistance of the divided voltage point to the ground, R61, R62 and R63, are fixed at 10KΩ. Assuming that the highest input voltage is 32V and the resistance of the divided voltage point to the phase voltage is 75KΩ, the divided voltage can be calculated as:

$$32V \times \frac{10K\Omega}{10K\Omega + 75K\Omega} = 3.76V$$

BEMF circuit

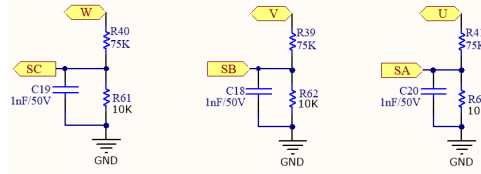

Back EMF Detection Circuit

2-12 RF Receiver Module

The figure below shows the Low-IF OOK receiver module with a 433MHz frequency band, the BM2302-64-1. If there is a long-distance remote control requirement, users can purchase this module on the Best Modules official website. The hardware board does not include this module by default.

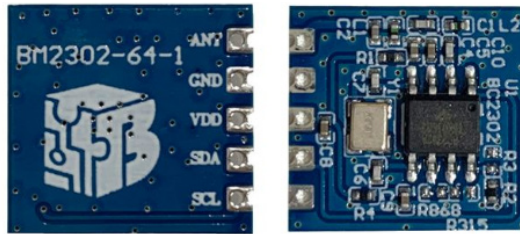

back view

front view

RF Receiver Module

2-13 MCU Standby and Wake-up Function

The first figure below is the J1 jumper switch function diagram. If the MCU requires a standby state with zero power consumption, short the pin1 to pin2 of the J1 pin header on the upper MCU board. As shown in the second figure below, the TP5 pin header on the lower board can input a 5V~VM voltage through a Dupont line. The voltage can be provided to the HT32F65440A_MCU upper board through the SW3 button to wake up the MCU. The pin2 and pin3 of the J1 jumper header on the HT32F65440A_MCU upper board can be shorted if there is no power saving mode.

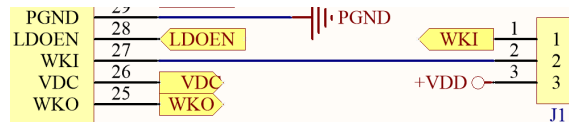

J1 Jumper Switch Function

Wake up

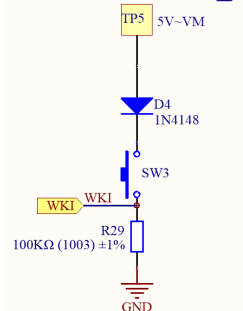

Wake-up Function

2-14 FG Speed Function

The figure below shows the FG speed function. Use the jumper to short the pin1 to pin2 of the J1 pin header on the lower board to use the integrated FG function of the HT32F65440A MCU which requires no external components. Since the internal MOSFET is open-drain, the J1 pin header can be shorted using a jumper to pull the FG output voltage to the VM.

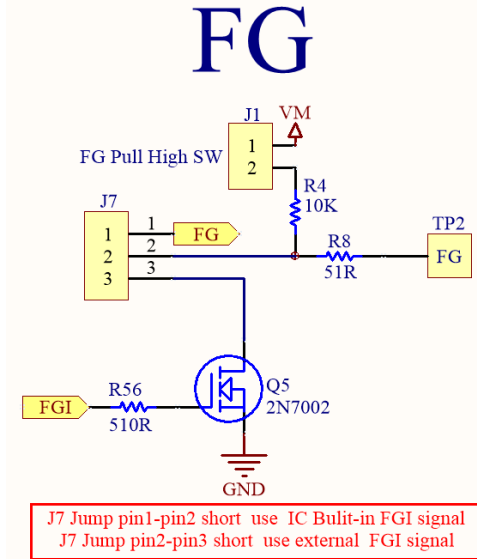

FG Speed Function

2-15 PWM Command Function

The figure below shows the PWM command function. By connecting the external PWM command to the TP3 pin header and using Q1 MOSFET to invert the PWM signal, the reverse PWM command signal is obtained.

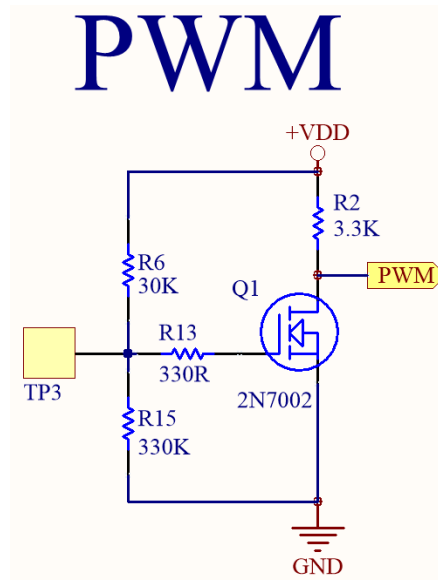

PWM Command Function

2-16 MCU Pin Function Definition

The figure below shows the HT32F65440A pin circuit. Refer to the following table for the MCU pin function definition.

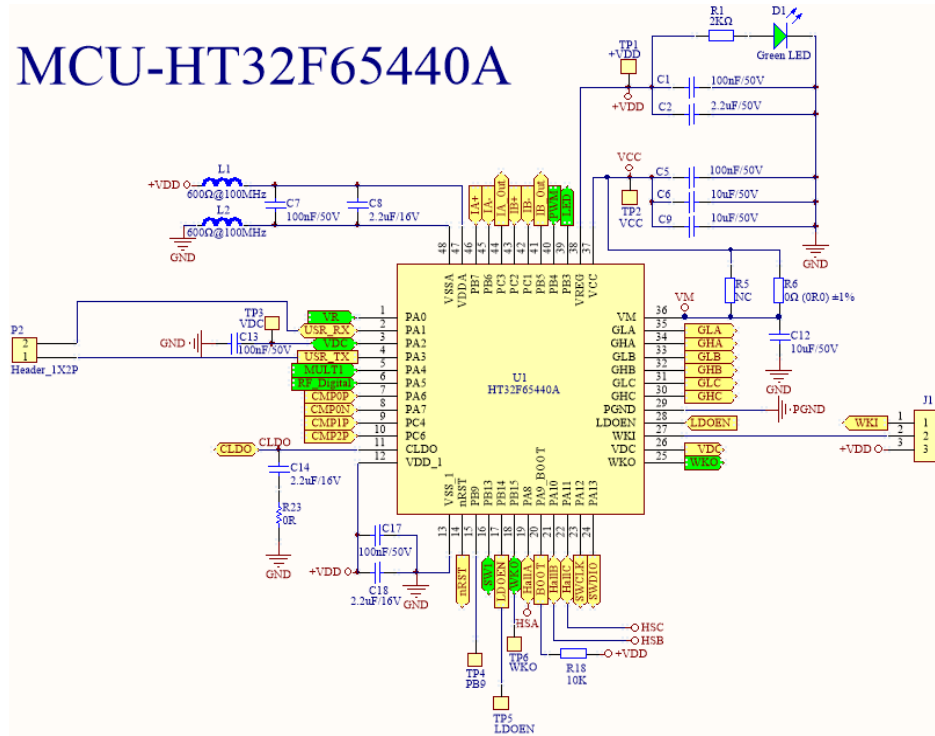

HT32F65440A Pin Circuit Diagram

PA0 (VR)	PA1 (USR_RX)	PA2 (VDC)
PA3 (USR_TX)	PA4 (RF_INT & NTC)	PA5 (RF Digital)
PB13 (SW1)	PB14 (LDOEN)	PB15 (WKO)
PA8 (HSA)	PA10 (HSB)	PA11 (HSC)
PB3 (LED)	PB4 (PWM)	

MCU Pin Function Definition

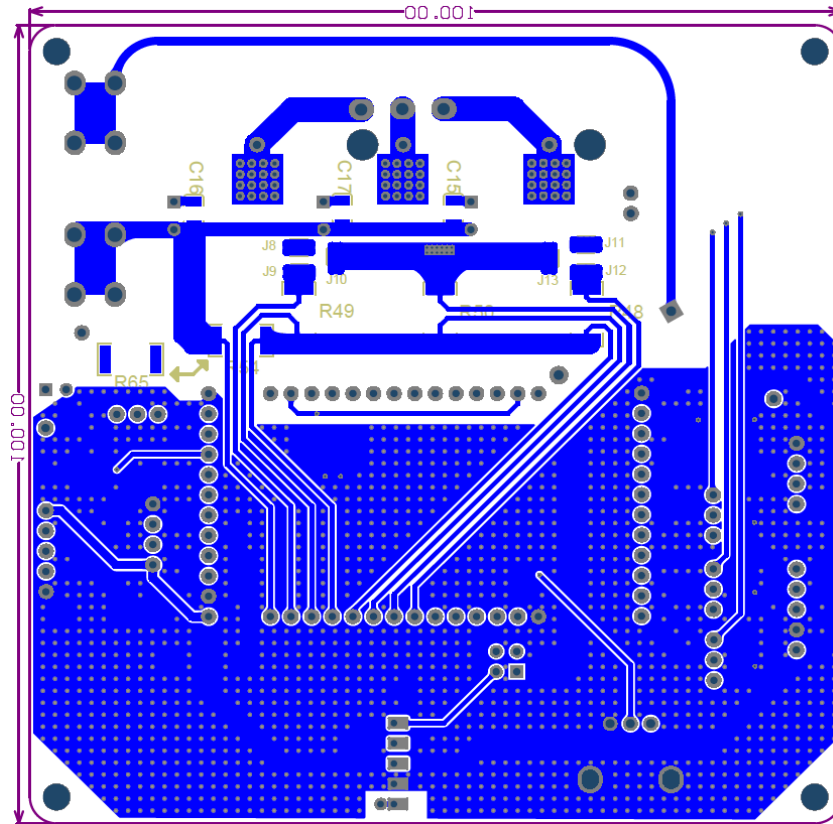

HT32 BLDC Motor P/N MOS Power Board_Bottom Layer

The figures below show the HT32F65440A_MCU Board PCB Layout, the detailed specifications are shown in the table below.

Length × Width	59.5×34 (mm)
Thickness	1.6 (mm)
Number of Layers	2
Copper Foil Thickness	1 (Oz)
Material	FR-4
Solder Mask Layer Color	Blue

HT32F65440A_MCU Board Specifications

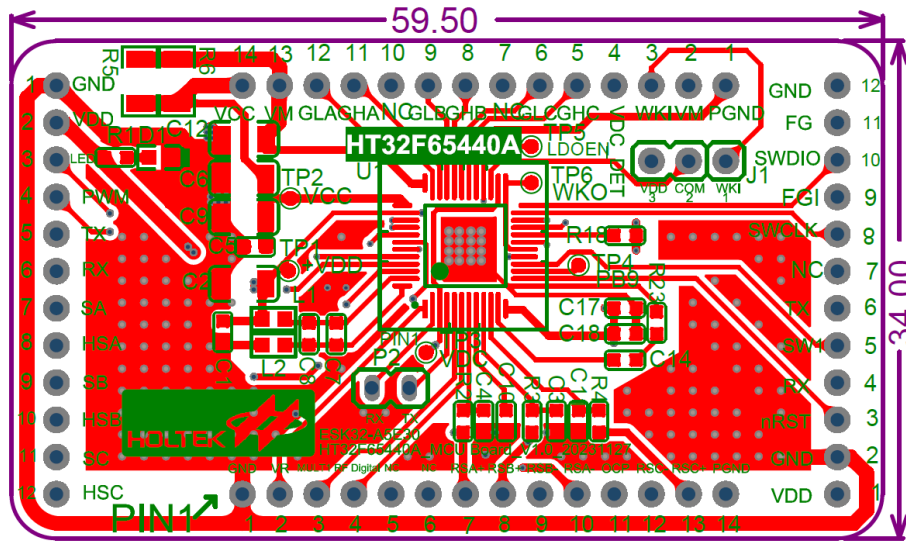

HT32F65440A_MCU Board_Top Layer

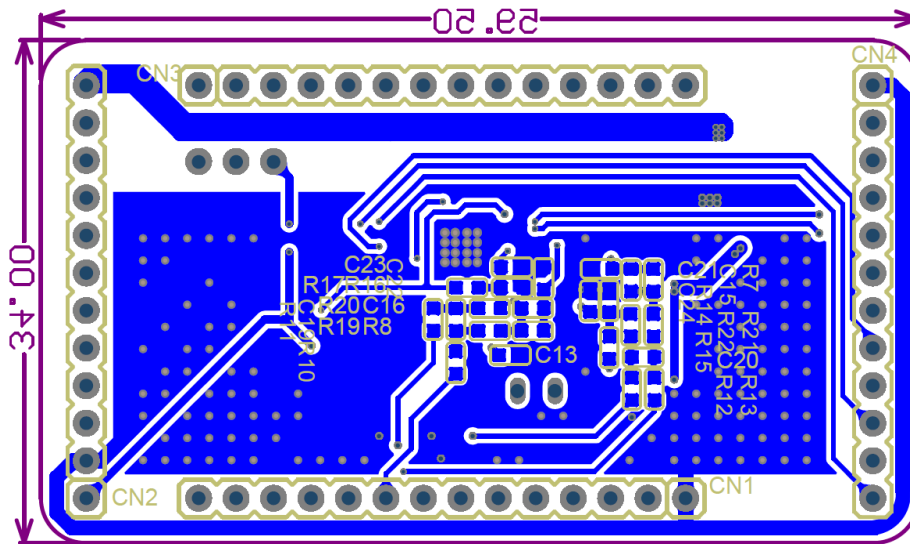

HT32F65440A_MCU Board_Bottom Layer

4. BOM List

The following table shows the HT32 BLDC Motor P/N MOS Power Board BOM List, which lists all the required components for the circuit boards.

Comment	Description	Designator	Quantity	Footprint
100nF±10% 50V X7R	MLCC	C2, C3, C4, C5, C6, C7	6	0603
1nF±5% 50V X7R	MLCC	C9, C10, C11,C18, C19, C20	6	0603
100nF±10% 100V X7R	MLCC	C15, C16, C17	3	1206
5.1V±5% 0.5W, MM1Z5V1	SMD zener diode	D1	1	SOD-123
1N4148	SMD diode	D4	1	SOD-123
SMD red LED, plain bright	SMD LED	D11	1	0603
UK-B0240G25-SP25Y	SMD button	SW1, SW2, SW3	3	SMD
2N7002	SMD N-ch MOSFET	Q1, Q5	2	SOT-23
P2204ND5G-VB	SMD PN MOSFET	Q2, Q3, Q4	3	TO-252-4
51Ω±1%	SMD Resistor	R8	1	0603
100KΩ±1%	SMD Resistor	R23, R24, R29	3	0603
100Ω±1%	SMD Resistor	R1, R3, R5, R10, R57, R58, R59, R60	8	0603
0Ω	SMD Resistor	R18	1	1206
10KΩ±1%	SMD Resistor	R4, R61, R62, R63	4	0603
75KΩ±1%	SMD Resistor	R9, R39, R40, R41	4	0603
0Ω	SMD Resistor	R64	1	0805
2KΩ±1%	SMD Resistor	R55	1	0603
3.3KΩ±1%	SMD Resistor	R2	1	0603
1KΩ±1%	SMD Resistor	R16, R53	1	0603
50mΩ±1%	SMD Resistor	R48, R49, R50, R65	4	2512
0Ω	SMD Resistor	R54	1	2512
30KΩ±1%	SMD Resistor	R6	1	0603
330Ω±1%	SMD Resistor	R13	1	0603
330KΩ±1%	SMD Resistor	R15	1	0603
10Ω±1%	SMD Resistor	R36, R37, R38, R45, R46, R47	6	0603
4.7KΩ±1%	SMD Resistor	R20, R21, R22, R26, R27, R28	6	0603
510Ω±1%	SMD Resistor	R56	1	0603
4.99KΩ±1%	SMD Resistor	R14	1	0603
10KΩ±1%	SMD NTC negative resistor	R11	1	0603
1Pin,180 degrees	Single row	TP2, TP3, TP5, TP10, TP11, TP12	6	HEADER_1X1P
P=2.54mm,2Pin,180 degrees	Single row	J1	1	HEADER_1X2P
P=2.54mm,3Pin,180 degrees	Single row	J3, J5, J6, J7	4	HEADER_1X3P
P=2.54mm,4Pin,180 degrees	Single row	P5, P6	2	HEADER_1X4P
P=2.54mm,5Pin,180 degrees	Single row	CN5, P1	2	HEADER_1X5P
P=2.54mm,12Pin,180 degrees	Single row	CN2, CN4	2	HEADER_1X12P
P=2.54mm,14Pin,180 degrees	Single row	CN1, CN3	2	HEADER_1X14P
P=2.54mm,4Pin,180 degrees	Dual row	J2	1	HEADER_2X2P
Screw seat + M4 screw	Screw seat + M4 screw	DCIN, PGND	2	Screw seat + M4 screw

Comment	Description	Designator	Quantity	Footprint
100µF/63V 63ZLH100MEFC8X16	DIP aluminum electrolytic capacitor	C12, C13, C14	3	CEC 8X16H_P3.5
P=2.54mm,3Pin,90 degrees	Plug type terminal	P4	1	DIP3W-5.08
10KΩ±20% RK09K1130A5R	DIP variable resistor	R7	1	Through-hole
Jumper	Black Jumper		3	Pitch=2.54mm

HT32 BLDC Motor P/N MOS Power Board_BOM List

The following table shows the HT32F65440A_MCU Board BOM List, which lists all the required components for the circuit boards.

Comment	Description	Designator	Quantity	Footprint
HT32F65440A	32-bit MCU	U1	1	LQFP48_EP PAD
100nF±10% 50V X7R	MLCC	C1, C3, C4, C5, C7, C10, C11, C13, C17	9	0603
18pF±5% 50V NP0	MLCC	C15, C16	2	0603
33pF±5% 50V NP0	MLCC	C19, C20, C23, C24	4	0603
100pF±5% 50V NP0	MLCC	C21, C22	2	0603
2.2µF±10% 16V X7R	MLCC	C8, C14, C18	3	0603
2.2µF±10% 50V X7R	MLCC	C2	1	1206
10µF±10% 50V X7R	MLCC	C6, C9, C12	3	1206
Green LED	SMD LED	D1	1	0603
600Ω @ 100MHz±25%	SMD magnetic bead	L1, L2	2	0603
0Ω	SMD Resistor	R6	1	1206
0Ω	SMD Resistor	R23	1	0603
180Ω±1%	SMD Resistor	R10, R11, R12, R13	4	0603
680Ω±1%	SMD Resistor	R2, R3, R4	3	0603
820Ω±1%	SMD Resistor	R19, R20, R21, R22	4	0603
2KΩ±1%	SMD Resistor	R1	1	0603
7.5KΩ±1%	SMD Resistor	R7, R8	2	0603
10KΩ±1%	SMD Resistor	R18	1	0603
15KΩ±1%	SMD Resistor	R14, R15, R16, R17	4	0603
P=2.54mm,12Pin,180 degrees	Single row	CN2, CN4	2	HEADER_1X12P
P=2.54mm,14Pin,180 degrees	Single row	CN1, CN3	2	HEADER_1X14P
P=2.54mm,2Pin,180 degrees	Single row	P2	1	HEADER_1X2P
P=2.54mm,3Pin,180 degrees	Single row	J1	1	HEADER_1X3P
Jumper	Black Jumper		1	Pitch=2.54mm

HT32F65440A_MCU Board_BOM List

Copyright© 2024 by HOLTEK SEMICONDUCTOR INC. All Rights Reserved.

The information provided in this document has been produced with reasonable care and attention before publication, however, HOLTEK does not guarantee that the information is completely accurate. The information contained in this publication is provided for reference only and may be superseded by updates. HOLTEK disclaims any expressed, implied or statutory warranties, including but not limited to suitability for commercialization, satisfactory quality, specifications, characteristics, functions, fitness for a particular purpose, and non-infringement of any third-party's rights. HOLTEK disclaims all liability arising from the information and its application. In addition, HOLTEK does not recommend the use of HOLTEK's products where there is a risk of personal hazard due to malfunction or other reasons. HOLTEK hereby declares that it does not authorize the use of these products in life-saving, life-sustaining or safety critical components. Any use of HOLTEK's products in life-saving/sustaining or safety applications is entirely at the buyer's risk, and the buyer agrees to defend, indemnify and hold HOLTEK harmless from any damages, claims, suits, or expenses resulting from such use. The information provided in this document, including but not limited to the content, data, examples, materials, graphs, and trademarks, is the intellectual property of HOLTEK (and its licensors, where applicable) and is protected by copyright law and other intellectual property laws. No license, express or implied, to any intellectual property right, is granted by HOLTEK herein. HOLTEK reserves the right to revise the information described in the document at any time without prior notice. For the latest information, please contact us.