

Features

- 1 Channel H-Bridge Motor Driver: Low MOSFET On-resistance: 0.75Ω (HS+LS)
- Wide V_{DD} Input Voltage Range of 2.5V to 5.5V
- Maximum Motor Power Supply V_M : 24V
- Maximum 2.0A Motor Peak Current
- Four Operation Modes: Forward, Reverse, Brake and Standby
- Low Sleep Current $< 1\mu A$
- Automatic Enters into Sleep Period by Reset both IN1 and IN2 over 10ms
- Split Controller and Motor Power Supplies: VDD and VM
- Isolation Motor Current Sensing Pin: PGND
- Up to 200kHz PWM Input Control Operation
- IN1/IN2 Pull Down Resistor Internally
- Protection Features:
 - ♦ V_{DD} Under Voltage Lock-Out
 - ♦ Over Current Protection
 - ♦ Thermal Shutdown Protection
 - ♦ Output Short Circuit Protection
- Package Type: 8-pin SOP-EP
- Operation Temperature Range: $-40^\circ C$ to $+85^\circ C$

Applications

- Swing head motors, white appliance, valve/pump, electric locks

General Description

The HT7K1401 is a 1-channel H-bridge driver with a maximum motor peak current of 2.0A. Its outstanding low on-resistance characteristic results in excellent output efficiency which is a major advantage in battery powered systems. A simple two input control pin structure is used to provide four control modes: Forward, Reverse, Brake and Standby modes. With a PWM input control frequency of up to 200kHz, accurate speed control can be implemented for a wide variety of applications. A full range of protection functions are integrated including OCP, OSP and OTP to prevent device damage even if the motor stalls or experiences a short circuit in critical operating environments. As the automatic sleep period activation mechanism uses the same mode control pins, an additional extra shutdown signal is not required. In addition, a low $1\mu A$ sleep period current ensures long battery life. The device also includes separate power supplies for the control circuits and the motor power supply and also includes a current sensing pin to allow the system to measure the motor current using an external resistor.

Typical Application Circuit

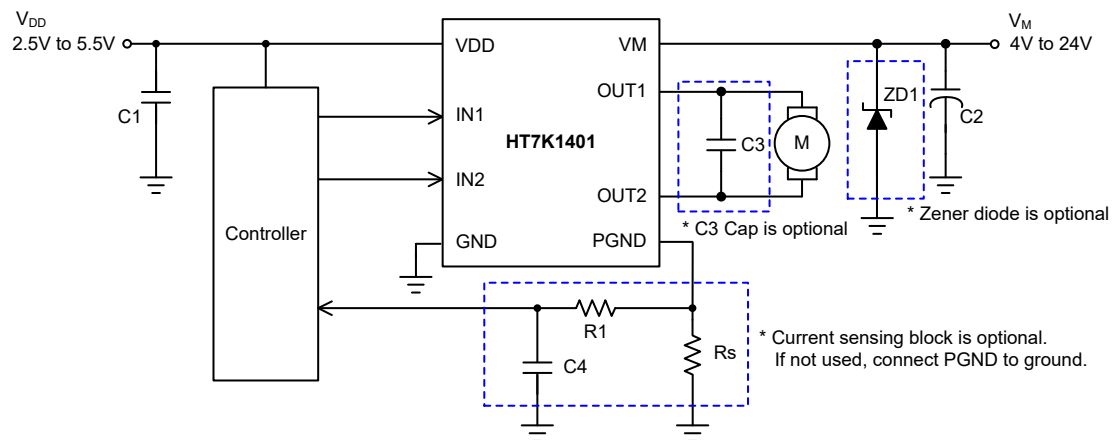

Pin Description

Pin Order	Name	Type	Pin Discription
1	GND	G	Analog Ground
2	IN2	I	Control Input 2 220kΩ pull down resistor internally
3	IN1	I	Control Input 1 220kΩ pull down resistor internally
4	VDD	P	IC Power supply
5	VM	P	Motor Power supply
6	OUT1	O	H-Bridge Output 1
7	PGND	G	Motor Current Sensing Terminal Connect via a sensing resistor to GND. If it is not necessary to sense the motor current, the PGND line should be directly connected to GND.
8	OUT2	O	H-Bridge Output 2
EP	GND	G	Thermal Enhance Pad. Connected to GND

Note: I: Input; O: Output; P: Power; G: Ground

Absolute Maximum Ratings

Parameter	Value	Unit
V _{DD}	-0.3 to +6.0	V
V _M , OUT1, OUT2	-0.3 to +32	V
IN1, IN2	-0.3 to (V _{DD} +0.3)	V
PGND	±0.7	V
Operating Temperature Range	-40 to +85	°C
Maximum Junction Temperature	+150	°C
Storage Temperature Range	-65 to +160	°C
Lead Temperature (Soldering 10sec)	+260	°C
ESD Susceptibility	Human Body Model	±5000
	Machine Model	±400
Junction-to-Ambient Thermal Resistance, θ _{JA}	8SOP-EP	125

Recommended Operating Ratings

Parameter	Value	Unit
V _{DD}	2.5 to 5.5	V
V _{M(MAX)}	4 to 24	V
PGND _(MAX)	±0.5	V
I _{OUT(PEAK)}	2.0	A

Note that Absolute Maximum Ratings indicate limitations beyond which damage to the device may occur. Recommended Operating Ratings indicate conditions for which the device is intended to be functional, but do not guarantee specified performance limits.

Electrical Characteristics

 $V_{DD}=5V$, $V_M=12V$ and $T_A=+25^\circ C$, unless otherwise specified.

Symbol	Parameter	Test Condition	Min.	Typ.	Max.	Unit
Power Supply						
V_{DD}	Supply Voltage	—	2.5	—	5.5	V
I_{DD}	Supply Operation Current	PWM=25kHz, OUT1 and OUT2 open	—	0.75	0.95	mA
$I_{DD(STB)}$	Supply Standby Current	IN1=IN2="0", active period	—	750	950	μA
$I_{DD(SLP)}$	Supply Sleep Current	IN1=IN2="0", sleep period	—	0.1	1.0	μA
V_M	Motor Power Supply	—	—	—	24	V
I_M	V_M Operation Current	PWM=25kHz, no load	—	0.4	0.6	mA
$I_{M(STB)}$	V_M Standby Current	IN1=IN2="0", active period	—	250	375	μA
H-Bridge Driver						
R_{ON}	HS+LS FET On-resistance ⁽¹⁾	$V_{DD}=3.3V$, $I_{OUT}=500mA$	—	0.75	—	Ω
V_{CLAMP}	Clamp Diode Voltage	$I=300mA$ (HS and LS)	—	0.8	—	V
$I_{HS(OFF)}$	HS MOSFET Leakage Current	IN1=IN2="0", $V_M=12V$, $V_{OUT}=0V$, measure I (V_M)	—	—	1	μA
$t_{r(OUT)}$	Output Rise Time	$R_L=20\Omega$, 10% to 90% (Figure 1)	—	150	—	ns
$t_{f(OUT)}$	Output Fall Time	$R_L=20\Omega$, 90% to 10% (Figure 1)	—	100	—	ns
Control Logic						
V_{IL}	Input Logic Low Voltage	$V_{DD}=5V$	—	—	0.8	V
		$V_{DD}=2.5V$	—	—	0.4	V
V_{IH}	Input Logic High Voltage	$V_{DD}=5V$	2.00	—	—	V
		$V_{DD}=2.5V$	1.25	—	—	V
V_{HYS}	Input Logic Hysteresis	—	—	0.1	—	V
t_{P1}	IN-to-OUT Propagation Delay (Figure 1)	$R_L=20\Omega$, INx to OUTx (high-Z to high/low)	—	150	—	ns
t_{P2}		$R_L=20\Omega$, INx to OUTx (high/low to high-Z)	—	100	—	ns
t_{P3}		$R_L=20\Omega$, INx to OUTx	—	100	—	ns
t_{P4}		$R_L=20\Omega$, INx to OUTx	—	150	—	ns
t_{SLPEN}	Sleep Period Entry Time	IN1=IN2='0' until charge pump switches off (Figure 2)	—	10	—	ms
f_{PWM}	Input PWM Frequency	Internal charge pump activates	—	—	200	kHz
R_{PD}	Input Pull Down Resistance	IN1 and IN2	—	220	—	k Ω
Charge Pump						
t_{CP_ON}	Charge Pump on Time	Charge pump activates time (Figure 2)	—	10	—	ms
Protection						
V_{UVLO+}	V_{DD} Turn on Level	V_{DD} rises	—	—	2.5	V
V_{UVLO-}	V_{DD} Turn off Level	V_{DD} falls	2.0	—	—	V
I_{OCP}	Over Current Threshold	With deglitch time, t_{DEG}	2.0	2.4	—	A
t_{DEG}	Over Current Deglitch Time	(Figure 3, 5)	—	1	—	μs
t_{RETRY}	Over Current Retry Time ⁽³⁾	(Figure 3, 4, 5)	—	1	—	ms
I_{OSP}	Output Short Circuit Protection Threshold ⁽²⁾	Without deglitch time (Figure 4, 5)	—	3.6	—	A
T_{SHD}	Thermal Shutdown Threshold	—	—	150	—	$^\circ C$
T_{REC}	Thermal Recovery Temperature	—	—	120	—	$^\circ C$

Note: 1. HS means High Side and LS means Low Side.

2. The HT7K1401 device provides full short circuit protection for the OUTx-to-ground, OUTx-to-power or OUT1-to-OUT2 path.

3. The retry mechanism is only available in Forward and Reverse modes (Figure 5).

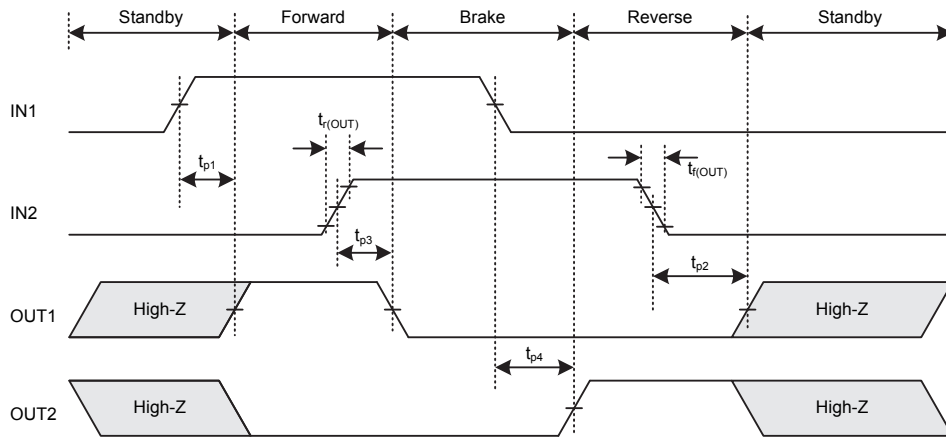

Figure 1. Operation Mode Control Logic in Active Period

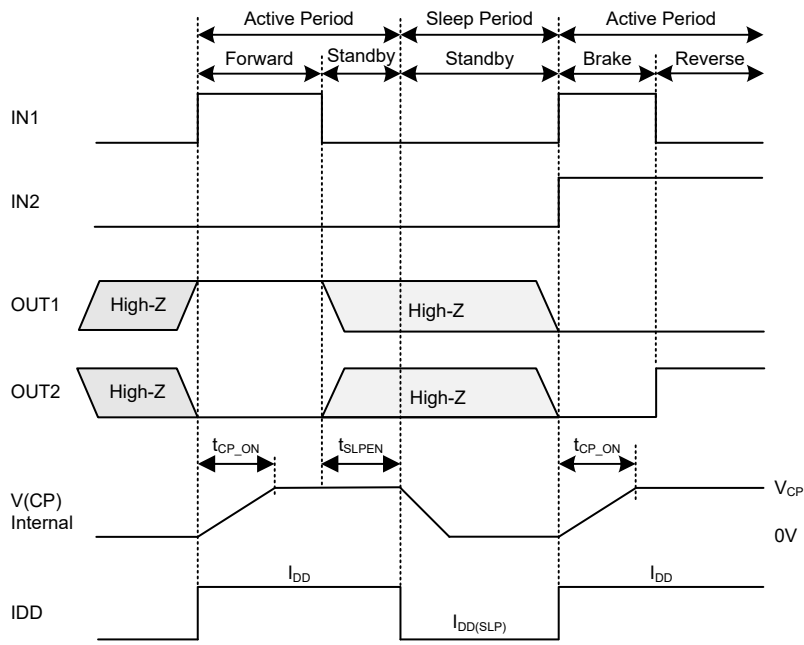

Figure 2. Operation Mode Control Timing Diagram

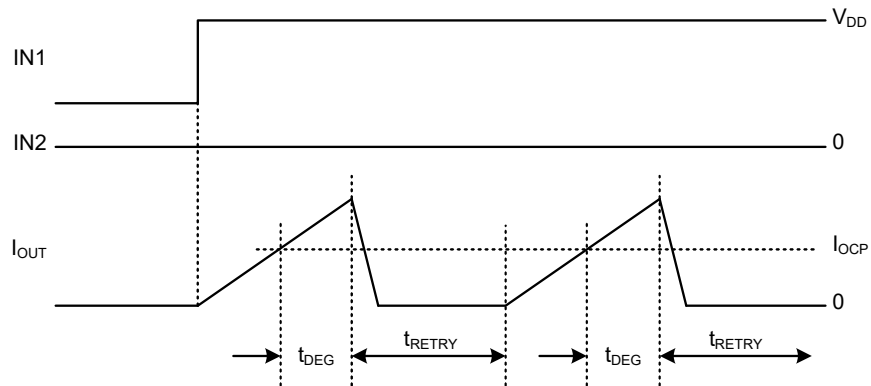

Figure 3. OCP Reaction

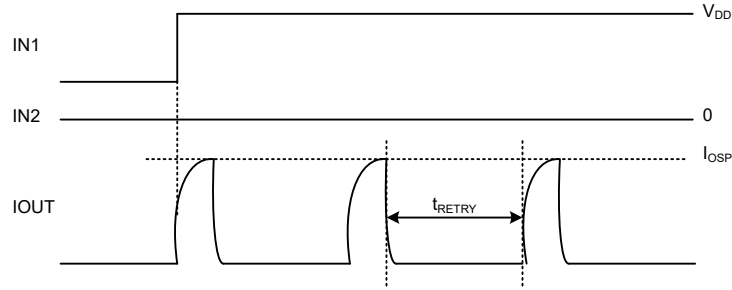

Figure 4. OSP Reaction

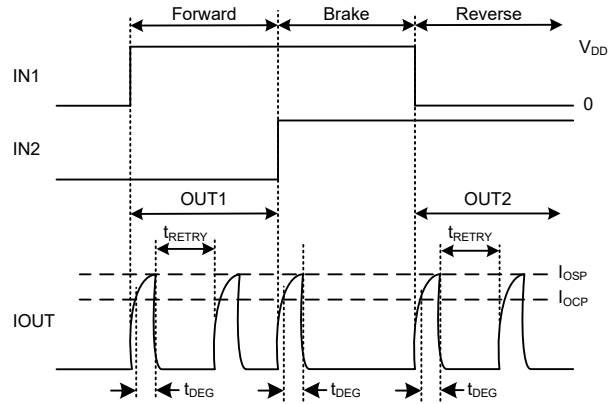
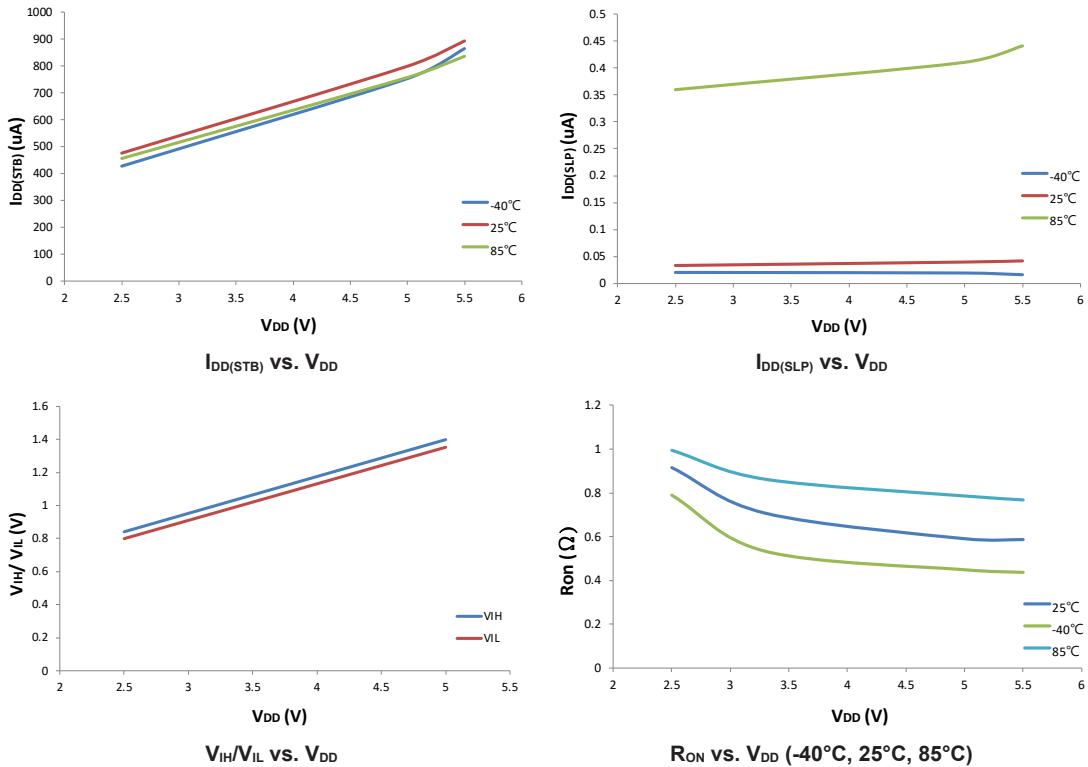
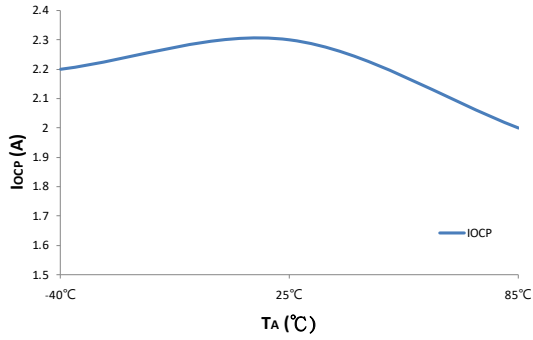

Figure 5. Retry Reaction

Typical Performance Characteristics





IOCP vs. Temperature

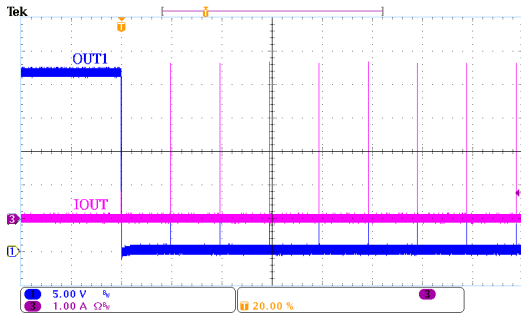

Short Circuit Protection Reaction

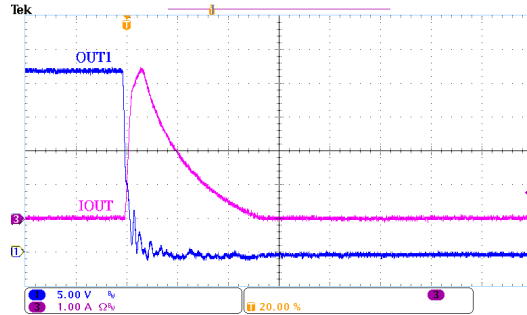

Short Circuit Protection Reaction (Zoom-in)

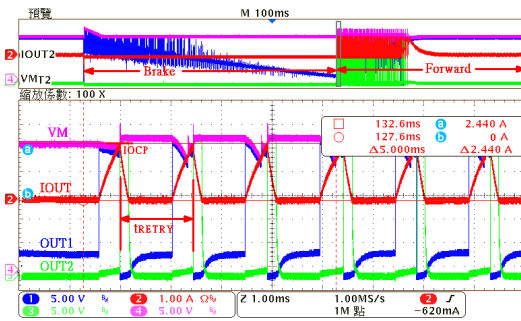

Forward Mode Active Retry Reaction

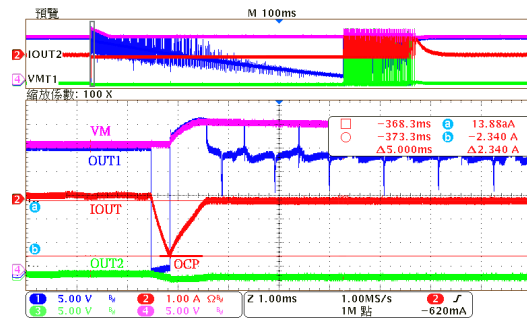

Brake Mode OCP Reaction

Functional Description

Overview

The HT7K1401 is a 1-ch H-bridge driver that can drive DC brush motors or solenoids. Due to the 4 internal very low on-resistance power MOSFETs which have parallel spark killer diodes and the excellent heat dissipating 8-pin SOP-EP package, the HT7K1401 motor driver has a high efficiency motor driving capability, reduced external components and outstanding thermal performance. Separate controller and motor power supplies allow for simplified system power domain design. The isolated motor current sensing pin, PGND, is designed to detect the motor current by connecting a resistor from this pin to ground. The device also includes a full range of protection functions including over-current and over-temperature to prevent the possibility of burn-out occurring even if the motor stalls or if the output pins are shorted to each other.

H-Bridge Control

According to the IN1 and IN2 pin states the device will generate four H-bridge output states: Standby, Forward, Reverse and Brake. The input/output operation truth table in active period is shown in Table 1. The input/output operation truth table in sleep period is shown in Table 2.

Active Period and Sleep Period

When the Standby mode continuously exceeds over 10ms, the HT7K1401 will enter the Sleep Period. At this time, the Standby mode still works in the Sleep Period

as shown in Table 2. The device will go back to the Active Period by changing the operation mode to Brake, Forward or Reverse mode (Figure 2).

In the Sleep Period, all functional blocks are turned off to reduce the current consumption to an ultra-low value of less than 1 μ A (max.). Since all functional blocks are turned off, the Standby mode outputs are not protected. When an IN1 or IN2 pin is set to “High”, the device will exit from the Sleep Period.

V_{DD} under Voltage Lock-Out

In order to avoid an H-bridge metastable output condition when powered-on or with a low battery voltage, an under voltage lockout function is integrated within the device. During the power-on period, the H-bridge outputs will remain in high impedance states and the control inputs are ignored when V_{DD} is lower than V_{UVLO+}. The H-bridge outputs are only controlled by inputs when V_{DD} is higher than V_{UVLO+}. The device will be locked again when V_{DD} falls to a voltage level lower than V_{UVLO-}.

Over Current Protection – OCP

The HT7K1401 device includes a fully integrated over current protection function within each of the internal power MOSFETs. When the motor current exceeds the over current protection threshold, I_{OCP}, exceeding a de-glitch time, t_{DEG}, all power MOSFETs will be turned off immediately. After the retry time times out, the device will release the protection activation and allow normal operation to resume. The retry mechanism is only available in Forward and Reverse modes (Figure 6).

IN1	IN2	OUT1	OUT2	Operation Mode	H-Bridge Status			
					M1	M2	M3	M4
0	0	Z	Z	Standby	OFF	OFF	OFF	OFF
0	1	L	H	Reverse	OFF	ON	ON	OFF
1	0	H	L	Forward	ON	OFF	OFF	ON
1	1	L	L	Brake	OFF	ON	OFF	ON

Table 1. Operation Truth Table in Active Period

IN1	IN2	OUT1	OUT2	Operation Mode	H-Bridge Status			
					M1	M2	M3	M4
0	0	Z	Z	Standby	OFF	OFF	OFF	OFF

Table 2. Operation True Table in Sleep Period

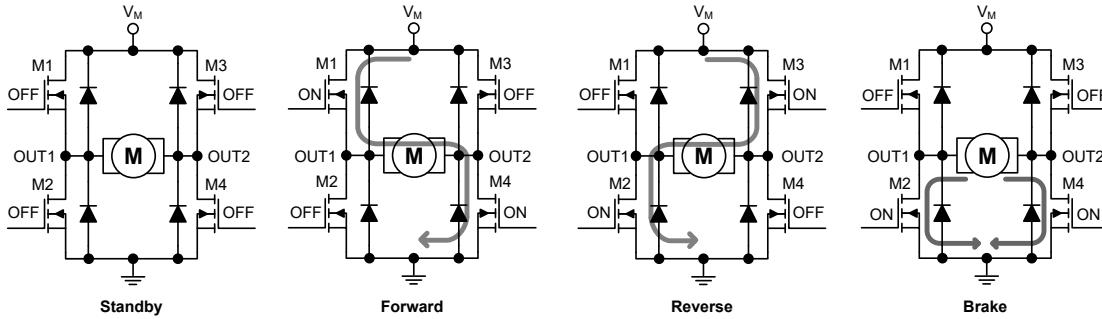

H-Bridge Operation Modes

Output Short Circuit Protection – OSP

The device provides full output protection for conditions such as an output pin short to ground, to the motor supply or to each other. The device detects the current through each power MOSFET and compares it with the output short circuit protection threshold, I_{OSP} , without a de-glitch time. The current threshold I_{OSP} is internally set to 1.5 times the I_{OCP} . When an OSP condition occurs, the device will turn off all power MOSFETs and keep checking the output status every retry time, t_{RETRY} , until the fault is removed. The retry mechanism is only available in Forward and Reverse modes (Figure 6).

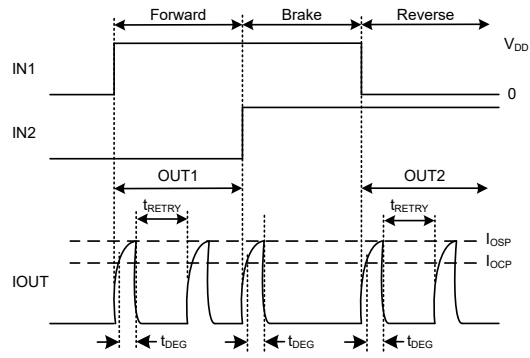

Figure 6. Retry Mechanism

Over Temperature Protection – OTP

If the die temperature exceeds the internal limit threshold, T_{SHD} , the device will turn off all power MOSFETs until the temperature decreases to a specific level less than the recovery temperature, T_{REC} .

The retry mechanism entry and release conditions are shown as follows.

Protection Type	Retry Entry Condition	Operation Mode			Retry Release Condition
		Forward/Reverse	Brake	Standby	
OCP	$I_{OCP} > 2.0A$	O	—	—	$I_{OCP} < 2.0A$
OSP	OUTx-to-ground, OUTx-to-power or OUT1-to-OUT2 path	O	—	—	Short circuit fault is removed

Table 3. Retry Mechanism Conditions

The protection function entry and release conditions are shown as follows.

Protection Type	Protection Entry Condition	Operation Mode			Protection Release Condition
		Forward/Reverse	Brake	Standby	
UVLO	$V_{IN} < 2.0V$	O	O	O	$V_{IN} > 2.5V$
OCP	$I_{OCP} > 2.0A$	O	O	—	$I_{OCP} < 2.0A$
OSP	OUTx-to-ground, OUTx-to-power or OUT1-to-OUT2 path	O	O	—	Short circuit fault is removed
OTP	$T_J > 150^{\circ}C$	O	O	O	$T_J < 120^{\circ}C$

Table 4. Protection Function Conditions

Motor Current Sensing

The HT7K1401 device can be used to implement a motor current sensing function by connecting an external resistor from PGND to GND. The PGND voltage is recommended to be kept lower than 0.5V to avoid turning on the protection diodes on the input pin such as the MCU ADC input. The current sensing resistor, R_s , is also recommended to be less than $0.5V/I_{M(max)}$, where $I_{M(max)}$ stands for the maximum motor current (motor stall current typical).

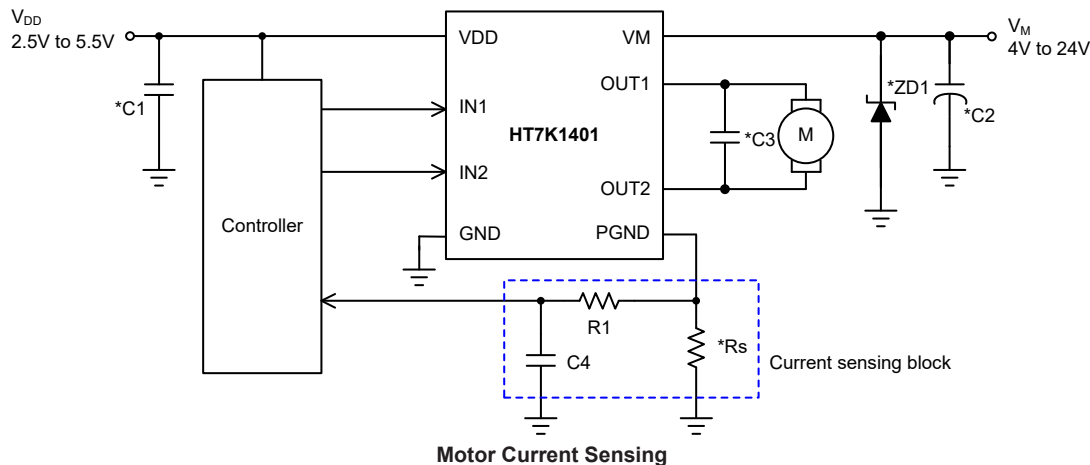

Power Dissipation

The main power dissipation in the HT7K1401 device is determined by the on-resistance of internal power MOSFETs. The average power dissipation can be estimated using the following equation:

$$P_{AVG} = R_{ON} \times (I_{OUT(RMS)})^2$$

Where P_{AVG} is the average power dissipation of the device, R_{ON} is the total on-resistance of HS and LS MOSFETs and $I_{OUT(RMS)}$ is the RMS or DC output current through the load. Note that the R_{ON} value will vary with the die temperature. The higher the die temperature is, the higher will be the R_{ON} value. When the ambient temperature increases or as the device heats up, the power dissipation of the device will also increase.

Component/Motor Selection Guide

Motor Consideration

The appropriate motor voltage depends upon the desired RPM and power supply source. Higher motor voltages also increase the motor current rate. Note that the motor stall current must be less than the internal limit output current, I_{OCP} , to avoid failures when the motor starts up.

Controller Supply Capacitor

It is suggested to use at least a 10 μ F value capacitor for C1. This provides the necessary power stability for the device excluding the H-Bridge.

Motor Supply Capacitor

It is suggested to use at least a 10 μ F value capacitor for C2. There are two main functions for this capacitor. Firstly, it absorbs the energy released by the motor to reduce any overshoot voltage damage. Secondly, it provides a transient power source to the motor to compensate for the battery response time or for long connecting wire effects when the motor starts up or for fast control switching between forward and reverse modes.

Motor Bypass Capacitor

The bypass capacitor, C3, provides the fast flywheel path to release the inductive energy of the motor. In most applications, the capacitance value is set to a value of 0.01 μ F to 0.1 μ F. Usually this capacitor is internally contained within the motor and not required externally. In some applications, especially in low speed motors, the large internal motor resistor connected with the bypass capacitor in parallel may result in an instantaneous large current when the motor starts up. It may however trigger a faulty OCP/OSP reaction which will fail to start up the motor. There are two ways to solve this phenomenon: decrease the bypass capacitor value or add a 47 Ω to 100 Ω resistor in series with the bypass capacitor.

Motor Current Sensing Resistor

The power dissipation of the selected motor current sensing resistor should be considered carefully. As described in the Functional Description section, the PGND maximum voltage should be lower than 0.5V. For a selected maximum motor current $I_{M(max)}$, the maximum power dissipation of current sensing resistor can be calculated by $0.5V \times I_{M(max)}$. For instance, if the $I_{M(max)}=1A$, the rated power of the selected current sensing resistor should be greater than 0.5W.

Motor Voltage Zener Diode

The Zener Diode, ZD1, is optional and located at the input of the VM pin to prevent the motor's back EMF voltage from flowing into the VM pin. This back EMF voltage may exceed the IC's rated voltage and cause damage. The ZD1 is set to a value of 32V.

Layout Consideration Guide

To reduce the problems with conducted noise, there are some important points to note on the PCB layout.

1. The input capacitor C1 must be placed close to the VDD pin.
2. The motor supply capacitor C2 must be placed close to the VM pin.
3. The bypass capacitor C3 is optional and should be placed close to the motor side.
4. Ensure that the power routing path such as VM, OUT1, OUT2 and PGND is as wide as possible.
5. Extra via holes nearby the device will assist with heat sinking.

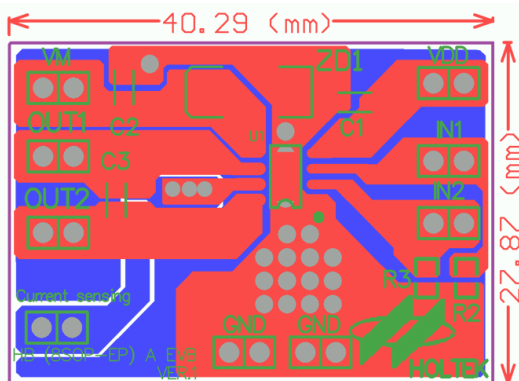

Thermal Consideration

The maximum power dissipation depends upon the thermal resistance of the IC package, PCB layout, rate of surrounding airflow and difference between the junction and ambient temperature. The maximum power dissipation can be calculated by the following formula:

$$P_{D(MAX)} = (T_{J(MAX)} - T_a) / \theta_{JA} \quad (W)$$

where $T_{J(MAX)}$ is the maximum junction temperature, T_a is the ambient temperature and θ_{JA} is the junction-to-ambient thermal resistance of IC package.

For maximum operating rating conditions, the maximum junction temperature is 150°C. However, it's recommended that the maximum junction temperature does not exceed 125°C during normal operation to maintain high reliability. The de-rating curve of the maximum power dissipation is show below:

$$P_{D(MAX)} = (150^\circ C - 25^\circ C) / (125^\circ C/W) = 1.0W$$

For a fixed $T_{J(MAX)}$ of 150°C, the maximum power dissipation depends upon the operating ambient temperature and the package's thermal resistance, θ_{JA} . The de-rating curve below shows the effect of rising ambient temperature on the maximum recommended power dissipation.

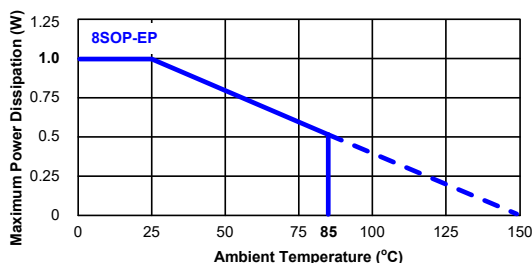

Application Circuits

Without Motor Current Sensing Application Circuits

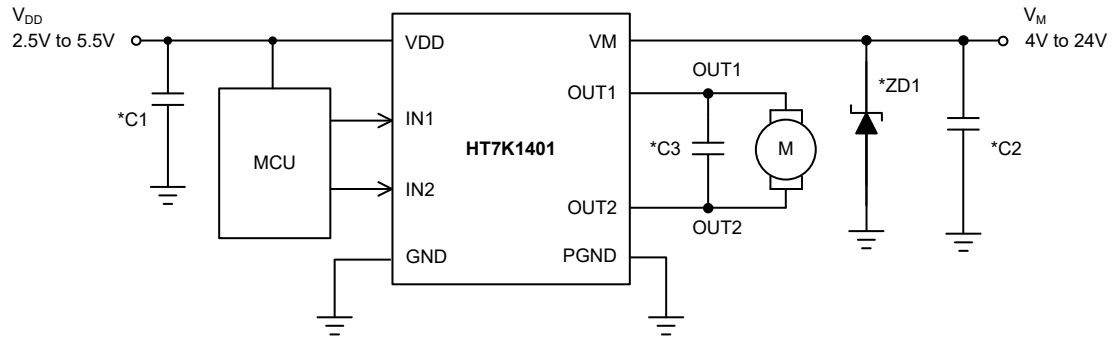

With Motor Current Sensing Application Circuits

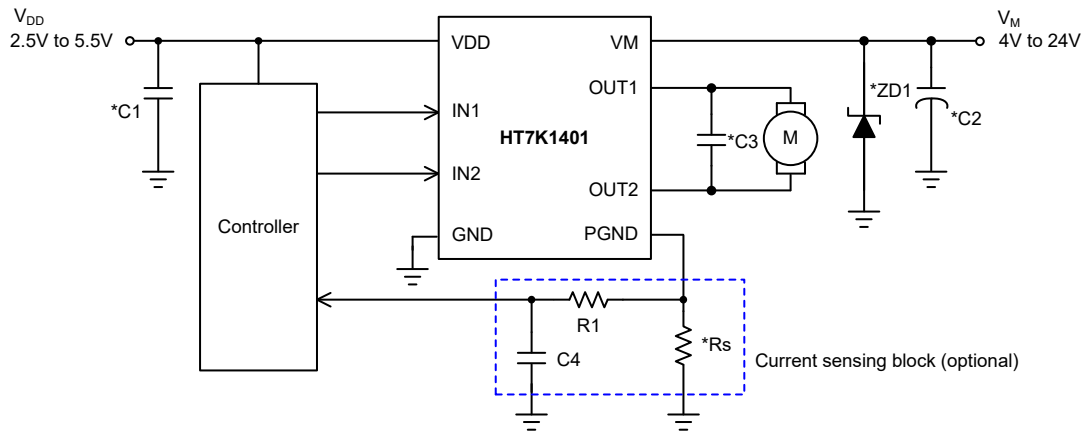

Note: * The capacitance value of $C1=10\mu\text{F}$ is recommended. The capacitance of $C2$ is determined by application – a typical value of $C2=10\mu\text{F}$.

* $C3$ is optional – a typical value ranges from $0.01\mu\text{F}$ to $0.1\mu\text{F}$.

* $ZD1$ is optional – a typical value of 32V(DIODES 1N4752A).

* RS is the motor current sensing resistor. Typically, the maximum sensing voltage is recommended to be less than 0.5V.

* The motor stall current should be less than the over current protection threshold, I_{OCP} .

Package Information

Note that the package information provided here is for consultation purposes only. As this information may be updated at regular intervals users are reminded to consult the [Holtek website](#) for the latest version of the [package information](#).

Additional supplementary information with regard to packaging is listed below. Click on the relevant section to be transferred to the relevant website page.

- Further Package Information (include Outline Dimensions, Product Tape and Reel Specifications)
- Packing Materials Information
- Carton information

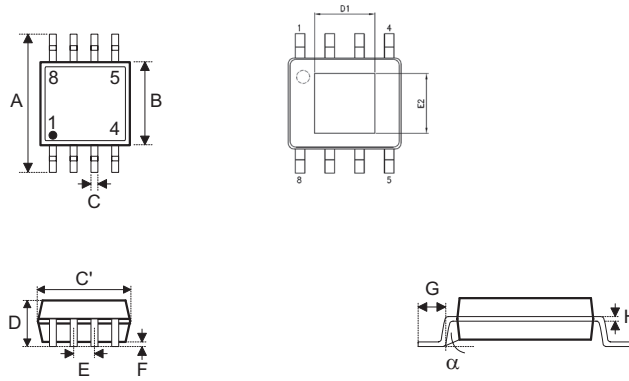
8-pin SOP-EP (150mil) Outline Dimensions

Symbol	Dimensions in inch		
	Min.	Nom.	Max.
A	—	0.236 BSC	—
B	—	0.154 BSC	—
C	0.012	—	0.020
C'	—	0.193 BSC	—
D	—	—	0.069
D1	0.059	—	—
E	—	0.050 BSC	—
E2	0.039	—	—
F	0.000	—	0.006
G	0.016	—	0.050
H	0.004	—	0.010
α	0°	—	8°

Symbol	Dimensions in mm		
	Min.	Nom.	Max.
A	—	6.00 BSC	—
B	—	3.90 BSC	—
C	0.31	—	0.51
C'	—	4.90 BSC	—
D	—	—	1.75
D1	1.50	—	—
E	—	1.27 BSC	—
E2	1.00	—	—
F	0.00	—	0.15
G	0.40	—	1.27
H	0.10	—	0.25
α	0°	—	8°

Copyright© 2021 by HOLTEK SEMICONDUCTOR INC.

The information appearing in this Data Sheet is believed to be accurate at the time of publication. However, Holtek assumes no responsibility arising from the use of the specifications described. The applications mentioned herein are used solely for the purpose of illustration and Holtek makes no warranty or representation that such applications will be suitable without further modification, nor recommends the use of its products for application that may present a risk to human life due to malfunction or otherwise. Holtek's products are not authorized for use as critical components in life support devices or systems. Holtek reserves the right to alter its products without prior notification. For the most up-to-date information, please visit our web site at <http://www.holtek.com>.