



**pH Value Water Quality Detection Module**

**BM25S4421-1**

Revision: V1.10 Date: September 18, 2024

[www.bestmodulescorp.com](http://www.bestmodulescorp.com)

## Table of Contents

<b>Features</b> .....	<b>3</b>
<b>General Description</b> .....	<b>3</b>
<b>Applications</b> .....	<b>3</b>
<b>Selection Table</b> .....	<b>3</b>
<b>Block Diagram</b> .....	<b>4</b>
<b>Pin Assignment</b> .....	<b>4</b>
<b>Pin Description</b> .....	<b>4</b>
<b>Technical Specifications</b> .....	<b>5</b>
Absolute Maximum Ratings .....	5
Recommended Operating Condition.....	5
D.C. Electrical Characteristics.....	5
A.C. Electrical Characteristics.....	5
Module pH Measurement Characteristics .....	7
<b>Functional Description</b> .....	<b>8</b>
System Description .....	8
<b>Interfaces</b> .....	<b>10</b>
I <sup>2</sup> C Interface .....	10
UART Interface.....	15
<b>Application Circuits</b> .....	<b>20</b>
I <sup>2</sup> C Mode .....	20
UART Mode.....	20
<b>Dimensions</b> .....	<b>20</b>
<b>Reference Information</b> .....	<b>21</b>
Modification History.....	21
Buy Online.....	21

## Features

- pH measurement features:
  - ♦ Measurement range: 0.00pH~14.00pH
  - ♦ Resolution:  $\pm 0.1$ pH
  - ♦ Resolution:  $\pm 0.1$ pH @ Module operating temperature 10°C~40°C, solution temperature 5°C~60°C
- Temperature measurement features:
  - ♦ Measurement range: 0°C~60°C
  - ♦ Resolution: 0.1°C
  - ♦ Accuracy:  $\pm 1$ °C
- Operating current:
  - ♦ Normal mode: <12mA @ 3.3V 25°C
  - ♦ Sleep mode: <4 $\mu$ A @ 3.3V 25°C
- Operating voltage: 3V~5.5V
- Optional communication interfaces:
  - ♦ I<sup>2</sup>C
  - ♦ UART



## General Description

The BM25S4421-1 is a digital output pH value water quality detection module, which integrates the pH detection, temperature detection and high-performance 24-bit Delta Sigma A/D converter. These features combined with algorithms make the module to have high accuracy, low power consumption characteristics, high product integration and small size. The BM25S4421-1 has automatic temperature compensation function and provides two communication methods, the I<sup>2</sup>C and the UART, for user's convenience.

## Applications

- Pen type pH meters
- Portable pH detectors
- Fish tank pH value monitors

## Selection Table

Part No.	Performance		Interface
	pH Value	Temperature	
BM25S4421-1	Measurement range: 0.00pH~14.00pH Resolution: 0.01pH Accuracy: $\pm 0.1$ pH	Measurement range: 0°C~60°C Resolution: 0.1°C Accuracy: $\pm 1$ °C	I <sup>2</sup> C/UART

\*Products are available from [Best Modules](#)

### Block Diagram

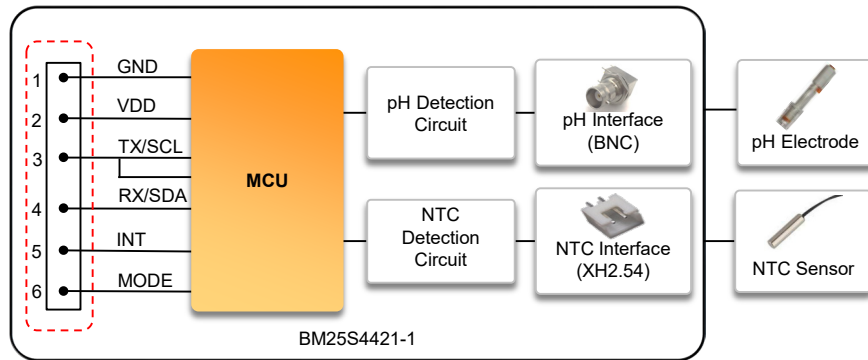

### Pin Assignment

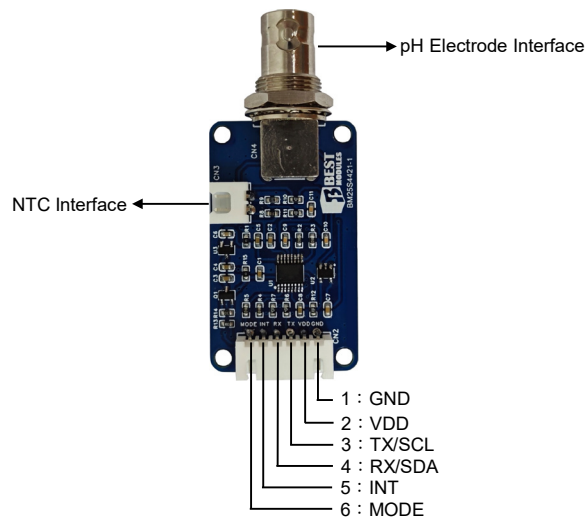

### Pin Description

Pin	Function	Type	Description
1	GND	PWR	Negative power supply, ground
2	VDD	PWR	Positive power supply
3	TX	O	Module UART data transmit pin
	SCL	I	I <sup>2</sup> C clock pin (with integrated 4.7k pull-up resistor)
4	RX	I	Module UART data receive pin
	SDA	I/O	I <sup>2</sup> C data pin (with integrated 4.7k pull-up resistor)
5	INT	O	Alarm signal output line
6	MODE	I	Communication mode selection pin. When MODE pin is floating or connected to high level, the communication mode is UART. When MODE pin is connected to low level, the communication mode is I <sup>2</sup> C.

Legend: PWR: Power;  
O: Digital output;

I: Digital input;  
I/O: Digital input/output

## Technical Specifications

### Absolute Maximum Ratings

Power Supply Voltage .....	GND-0.3V~GND+6.0V
Input Voltage .....	GND-0.3V~V <sub>DD</sub> +0.3V
Storage Temperature.....	-25°C~85°C
Operating (Ambient) Temperature .....	0°C~60°C
Total Power Consumption .....	<43mW @ 3.3V/25°C

Note: These are stress ratings only. Stresses exceeding the range specified under “Absolute Maximum Ratings” may cause substantial damage to the module. Functional operation of the devices at other conditions beyond those listed in the specification is not implied and prolonged exposure to extreme conditions may affect module reliability.

### Recommended Operating Condition

To achieve optimal module performance, it is recommended to operate the module within the temperature range of 10°C~40°C, if the module operates outside the temperature range, it will cause a decrease in the module pH measurement accuracy.

### D.C. Electrical Characteristics

T<sub>a</sub>=25°C

Symbol	Parameter	Test Conditions	Min.	Typ.	Max.	Unit
V <sub>DD</sub>	Operating Voltage	—	3	3.3	5.5	V
I <sub>DD</sub>	Operating Current	In normal mode (V <sub>DD</sub> =3.3V)	—	7	12	mA
		In sleep mode (V <sub>DD</sub> =3.3V)	—	2	4	μA
V <sub>IL</sub>	Input Low Voltage	—	0	—	0.2V <sub>DD</sub>	V
V <sub>IH</sub>	Input High Voltage	—	0.8V <sub>DD</sub>	—	V <sub>DD</sub>	V

### A.C. Electrical Characteristics

#### System Timing

T<sub>a</sub>=25°C, V<sub>DD</sub>=3.3V

Symbol	Parameter	Test Conditions	Min.	Typ.	Max.	Unit
t <sub>PU</sub>	Power-up time	Starting from V <sub>DD</sub> ≥3.1V to communication allowed	—	1000	—	ms
t <sub>RE</sub>	pH Value Refresh Time	—	—	4000	—	ms
t <sub>i</sub>	Module Response Time to host command	UART mode	—	—	50	ms
		I <sup>2</sup> C mode	50	—	—	ms
t <sub>RSP</sub>	Response Data Time (The specific time varies depending on the command)	UART mode	6	—	14	ms
		I <sup>2</sup> C mode	0.1	—	—	ms

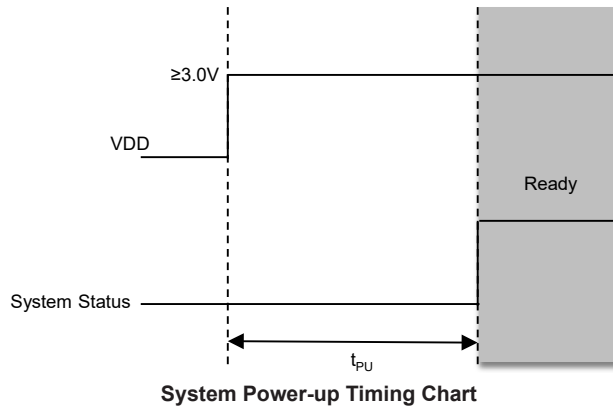

Note: System ready represents that the module has completed system initialisation and can receive commands from the host.

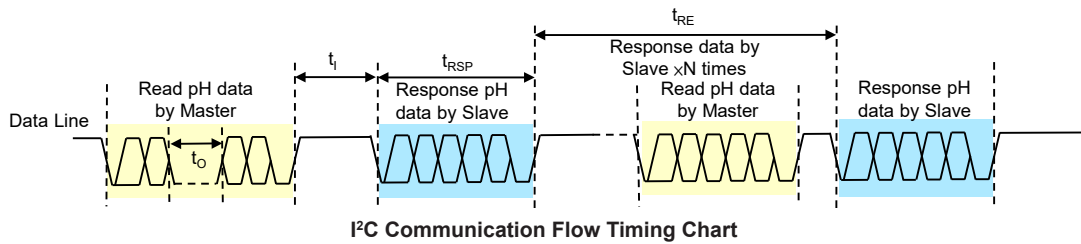
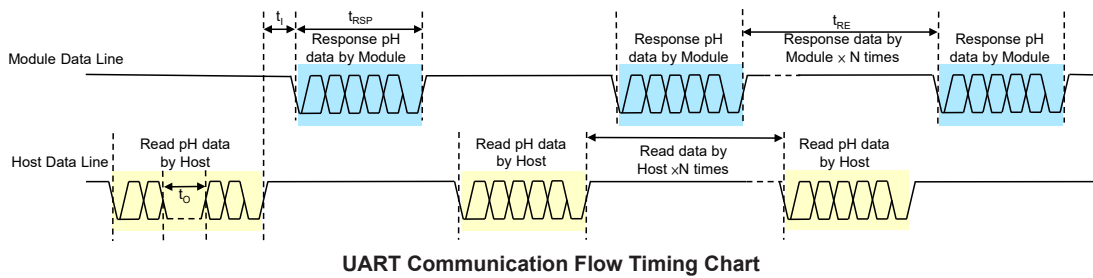

### UART Interface

$T_a=25^\circ C, V_{DD}=3.3V$

Symbol	Parameter	Test Conditions	Min.	Typ.	Max.	Unit
$t_o$	Data Received by the Module: the maximum time interval between bytes	—	—	10	—	ms

### I<sup>2</sup>C Interface

$T_a=25^\circ C, V_{DD}=3.3V$

Symbol	Parameter	Test Conditions	Min.	Typ.	Max.	Unit
$f_{SCL}$	Clock Frequency	—	5	—	400	kHz
$t_{IIC-time-out}$	I <sup>2</sup> C timeout protection time	—	—	10	—	ms

Note: The I<sup>2</sup>C master is required to support clock stretching function. The time-out counter starts counting on an I<sup>2</sup>C bus “START” & “address match” condition, and is cleared by an SCL falling edge. Before the next SCL falling edge arrives, if the time elapsed is greater than 10ms (typical value), then a time-out condition will occur. The time-out function will stop when an I<sup>2</sup>C “STOP” condition occurs.

### Module pH Measurement Characteristics

Parameter	Test Conditions	Min.	Typ.	Max.	Unit
pH Measurement Range	—	0.00	—	14.00	—
pH Measurement Accuracy	Module operates at 10°C~40°C	—	±0.1	—	—
pH Resolution	—	—	0.01	—	—
Maximum Temperature Measurement Range	—	0	—	60	°C
Recommended Temperature Measurement Range	—	5	—	60	°C
Temperature Measurement Accuracy	Within the range of 0~60°C	—	—	±1	°C
Temperature Measurement Resolution	Within the range of 0~60°C	—	0.1	—	°C

Note: 1. The temperature characteristics above are all tested using a constant temperature water tank, and the pH values are all tested using a pH standard solution.

2. The test uses E-201-C type pH composite electrode (electrode slope change ≤ 0.5% @ 5°C~60°C, electrode operating temperature range 5°C~60°C) and 3950 10K 1% NTC thermistor (corrosion resistant).

#### pH Electrode Requirements

- pH electrode: Suitable for E-201-C pH composite electrode. Electrode response time ≤ 2min, pH electrode zero drift value within 0±30mV, and pH electrode slope change ≤ 0.5% (The pH electrode slope at any temperature point between 5°C and 60°C minus the pH electrode slope at 25°C, absolute value ≤ 0.5%). Interface is BNC (Q9 male).
- The slope of the new electrode after calibration is between 95% and 105%. When the electrode slope is lower than 90%, it is recommended to replace the electrode.
- pH electrode slope measuring method: Construct a voltage follower circuit using a high input impedance operational amplifier, with the input connects to the pH electrode and the output connects to a high-resolution voltmeter. Record and measure the voltage values of the two different pH solutions, calculate the voltage corresponding to every 1pH, and divide the actual voltage by the theoretical voltage to obtain the pH slope. For example, when measuring a solution at 25°C, the actual voltage is 57.9768mV/pH, the theoretical voltage is 59.16mV/pH, and the slope of the pH electrode at 25°C is 98%. When measuring a solution at 15°C, the actual voltage is 56.089656mV/pH, the theoretical voltage is 57.176mV/pH, and the slope of the pH electrode at 15°C is 98.1%.
- When the electrode is not used, it requires to be fully immersed in the electrode protection liquid. It is recommended that the electrode protection solution should be replaced in time once a week.

#### NTC Sensor Requirements

- NTC sensor: R25=10K, accuracy: ±1%, B value: 3950K, B value accuracy: ±1%, or R25=10K, accuracy: ±1%, B value: 3435K, B value accuracy: ±1%. Interface XH2.54. Refer to the Interface section for the command for setting the NTC type used by the module.
- NTC sensor requires corrosion resistance.

## Functional Description

### System Description

The interface (BNC) on the BM25S4421-1 module is used to connect the pH electrode. The module will calculate the pH value of the solution by detecting the input pressure difference of the pH electrode, the module also has an interface (XH2.54) to connect to the NTC. Combined with the circuits on the module and internal algorithms, the pH temperature compensation function can be implemented.

### Operating Principle

After the system is powered on and initialised, the module will perform the first pH value and temperature value detection and determines the communication mode (UART/I<sup>2</sup>C) of the module based on the level of the MODE pin. Changing the MODE pin level cannot change the communication mode after this. The module will convert the pH value and temperature value every 4s. The module requires to use the sleep command to enter sleep, and the host requires to send a new command to wake up the module. The module reset command will restart the module initialisation. Refer to the Interface section for detailed communication mode.

### Setting the Alarm Value

The users can set the pH alarm value using commands. When the measured pH value is greater than the set pH high alarm value or the measured pH value is less than the set pH low alarm value, the module INT pin will output a low level. Otherwise, the module INT pin will output a high level. After the module enters sleep, the module INT pin will output a high level.

### Calibration Operation

The module has the function of pH calibration. When users use a new electrode or have not calibrate while measure pH for a long time (for example more than half a month), users require to calibrate the pH of the module using calibration commands. The standard solution has a certain shelf life, and it is recommended to use fresh standard solutions.

The pH calibration adopts a three-point calibration method, namely pH4.00, pH6.86, and pH9.18. During the calibration, it requires to use a pH6.86 standard solution for calibration, followed by a pH4.00 standard solution for calibration, and finally use a pH9.18 standard solution for calibration. When the module detects that the pH electrode voltage exceeds the limit range during calibration, the calibration solution will be considered unsuitable and the module will prompt calibration failure; For example, when calibrating pH 4.00, the electrode was mistakenly placed in a pH 2.0 solution. Here provides a calibration procedure for users to refer to (The module supported pH calibration temperature is 25 °C, and pH solutions at different temperatures will generate different pressure differentials at the electrode output terminal. If the user does not calibrate pH at 25 °C, although pH can be measured after calibration, it will affect the accuracy of pH measurement):

- Place the pH electrode and NTC probe in a 25°C constant temperature water tank for 3 minutes to keep the pH electrode at 25°C.
- Take 9 plastic containers. The containers require to be cleaned with deionized water in advance and dried naturally. The diameter of the containers should not be less than 4cm and their height should not be less than 6cm.
- Take two containers and pour in pH6.86 standard solution, one is pH6.86 standard solution, the other is buffer solution. Take two containers and pour in pH4.00 standard solution, one is pH4.00 standard solution, the other is buffer solution. Take two containers and pour in pH9.18 standard solution, one is pH9.18 standard solution, the other is buffer solution. Take three containers and pour in deionized water. Ensure that the standard solution is in a constant temperature environment of 25°C.

- Immerse the pH electrode and NTC probe in the deionized water for cleaning, then take out and dry the surface of the pH electrode and NTC probe with clean absorbent paper. Immerse them in pH6.86 buffer solution and stir them slightly, then immerse them in pH6.86 standard solution and stir them slightly. Observe whether there are foams on the glass ball surface of the pH electrode and shake them off, wait for the pH value to stabilise (usually the pH value will stabilise after 90s) then send a pH calibration command. Refer to the Interface section for pH calibration command.
- Immerse the pH electrode and NTC probe in the deionized water again for cleaning, then take out and dry the surface of the pH electrode and NTC probe with clean absorbent paper. Immerse them in pH4.00 buffer solution and stir them slightly, then immerse them in pH4.00 standard solution and stir them slightly. Observe whether there are foams on the glass ball surface of the pH electrode and shake them off, wait for the pH value to stabilise (usually the pH value will stabilise after 90s) then send a pH calibration command. Refer to the Interface section for pH calibration command.
- Immerse the pH electrode and NTC probe in the deionized water again for cleaning, then take out and dry the surface of the pH electrode and NTC probe with clean absorbent paper. Immerse them in pH9.18 buffer solution and stir them slightly, then immerse them in pH9.18 standard solution and stir them slightly. Observe whether there are foams on the glass ball surface of the pH electrode and shake them off, wait for the pH value to stabilise (usually the pH value will stabilise after 90s) then send a pH calibration command. Refer to the Interface section for pH calibration command.

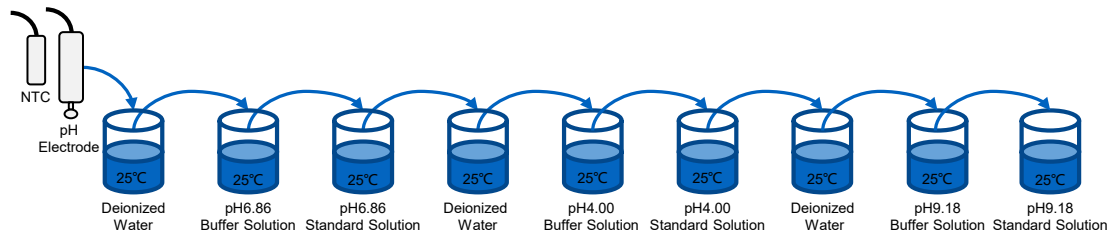

### Measurement of pH and Temperature Values Operation

Here provides a procedure of pH value and temperature value measurement for users to refer to:

- Place the pH electrode and NTC probe at the same temperature as the solution to be measured.
- Take three plastic containers. The containers require to be cleaned with deionized water in advance and dried naturally. The diameter of the containers should not be less than 4cm and their height should not be less than 6cm.
- Take two containers and pour in the solution to be tested, one of which is the solution to be tested, and the other is the buffer solution. Take a container and pour in the deionized water. Ensure that all the solutions are in the same constant temperature environment.
- Immerse the pH electrode and NTC probe in the deionized water again for cleaning, then take out and dry the surface of the pH electrode and NTC probe with clean absorbent paper. Immerse them in the buffer solution and stir them slightly, then immerse them in the solution to be tested and stir them slightly. Observe whether there are foams on the glass ball surface of the pH electrode and shake them off, then send a read pH value and temperature value command. Refer to the Interface section for the read pH value and temperature value command. When the pH value is stable, take the current pH value as the measurement result (generally the pH value will tend to be stable in 90s). The response time of the pH electrode below 20°C will be longer, and the pH value will be stable in 3~4 minutes generally. When measuring low conductivity water samples, such as rainwater,

deionized water, boiler water, river water, tap water, etc., the pH value may take a long time to be stable. If it is necessary to measure low conductivity samples, it is recommended to add an ionic strength regulator (such as potassium chloride)).

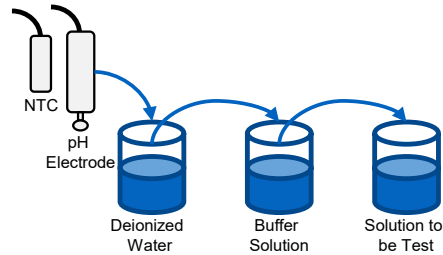

## Interfaces

The BM25S4421-1 supports I<sup>2</sup>C and UART communication modes. In these two communication modes, the master can read measurement values (pH value and temperature), module information and set the pH alarm value from the BM25S4421-1. And in UART communication mode, the command of setting module ID is added. Refer to the following content for protocol details.

### I<sup>2</sup>C Interface

#### Slave Addressing

- The BM25S4421-1 default address bits are “0000011”, and the module ID is used as the slave address.

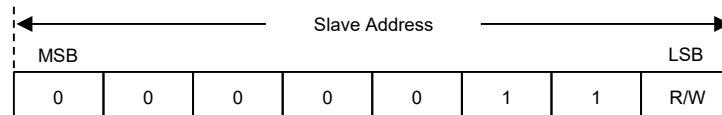

#### I<sup>2</sup>C Communication Protocol

- How to read BM25S4421-1

The communication of the BM25S4421-1 is established based on the I<sup>2</sup>C standard protocol. The maximum frequency of SCL is 400kHz, which is mainly divided into two steps: sending commands and reading values. First, the Master needs to transmit commands to the module, and the Module will parse the commands after receiving the commands. After the Master confirms that the module is online and has a response, it will read the value of the module.

#### Master Write Module Communication Frame Format

Module Address+Write	Frame Header 0x42,0x4D	Module Categories 0x63	ID Code Initial: 0x03	Master Command Code (HCMD)	Length (LEN)	Data (DATA)	Checksum (CS)
1-byte	2-byte	1-byte	1-byte	1-byte	1-byte	n-byte	1-byte

- Length (LEN)=number of Data (DATA) bytes
- Checksum (CS)=~(Frame Header+Module Categories+ID Code+Master Command Code+Length+Data Code)+1

**Master Read Module Communication Frame Format**

Module Address+Read	Frame Header 0x42,0x4D	Module Categories 0x63	ID Code Initial: 0x03	Module Command Code (MCMD)	Length (LEN)	Data (DATA)	Checksum (CS)
1-byte	2-byte	1-byte	1-byte	1-byte	1-byte	n-byte	1-byte

- ◆ Length (LEN)=number of Data (DATA) bytes
- ◆ Module Command Code (MCMD)=Master Command Code (HCMD)+0x80
- ◆ Checksum (CS)=~(Frame Header+Module Categories+ID Code+Module Command Code+Length+Data Code)+1

**Command Description**

Master Command Code (HCMD)	Data (DATA)		Description	Range (DEC)
Read the pH value and temperature value (0x01)	Master write to Module	None	—	—
	Master read from Module	DATA[0]	pH data higher eight bits (bit8~bit15)	0~1400 (0.00~14.00) 1500: pH data is higher than the measurement upper limit
		DATA[1]	pH data lower eight bits (bit0~bit7)	65436: pH data is less than the measurement lower limit
		DATA[2]	Temperature data higher eight bits (bit8~bit15)	0~600 (0.0°C~60.0°C)
		DATA[3]	Temperature data lower eight bits (bit0~bit7)	1500: NTC interface short 65036: NTC Interface open
<p>Example:            Master write to Module (HEX): 06 42 4D 63 03 01 00 0A            Master read from Module (HEX): 07 42 4D 63 03 81 04 02 BC 00 FA CE</p> <p>Note:            The pH data and temperature data read within 5s from V<sub>DD</sub>≥3.0V or 5s from wake-up is invalid.            pH value: 0x02BC→700→pH7.00, the module output pH value data is 100 times of the actual value, this indicates that the read pH value is 7.00            If the pH value is 0x05DC (1500) this indicates that the pH data is greater than the measurement upper limit. If the pH value is 0xFF9C (65436), this indicates that the pH data is less than the measurement lower limit.            When the module has not calibrated pH4.00 or pH6.86 or pH9.18, the pH value read is 0x0000→0→pH0.00.            Temperature value: 0x00FA→250→25.0°C, the module output temperature value data is 100 times of the actual value, this indicates that that the read temperature value is 25.0°C.            If the temperature value is 0x05DC (1500), this indicates that the NTC interface is short. If the temperature is 0xFE0C (65036), this indicates that the NTC interface is open.            When the measured temperature is greater than 60°C, the temperature value is 0x0258→600→60.0°C.            When the measured temperature is less than 0°C, the temperature value is 0x00→0→0.0°C.</p>				
Calibrate the pH (0x02)	Master write to Module	None	—	—
	Master read from Module	DATA[0]	pH type to be calibrated	0: Invalid 1: Calibrate pH4.00 2: Calibrate pH6.86 3: Calibrate pH9.18
		DATA[1]	Calibration status	1: Succeeded 0: Failed

Master Command Code (HCMD)	Data (DATA)	Description	Range (DEC)	
<p>Example: Master write to Module (HEX): 06 42 4D 63 03 02 00 09 Master read from Module (HEX): 07 42 4D 63 03 82 02 01 01 85</p> <p>Note: pH type to be calibrated: 0x01→1, this indicates that the pH type to be calibrated is pH4.00. Calibration Status: 0x01→1, this indicates that the calibration is successful. If the calibration has failed, the old calibration value will not be cleared.</p>				
Set pH alarm value (0x03)	Master write to Module	DATA[0]	pH high alarm value higher eight bits (bit8~bit15)	pH high alarm value: 1~1400(0.01~14.00) The pH high alarm value is greater than the pH low alarm value
		DATA[1]	pH high alarm value lower eight bits (bit0~bit7)	
		DATA[2]	pH low alarm value higher eight bits (bit8~bit15)	pH low alarm value: 0~1399(0.00~13.99) The pH low alarm value is less than the pH high alarm value
		DATA[3]	pH low alarm value lower eight bits (bit0~bit7)	
	Master read from Module	DATA[0]	Setting status	1: Succeeded 0: Failed
<p>Example: Master write to Module (HEX): 06 42 4D 63 03 03 04 04 B0 00 C8 88 Master read from Module (HEX): 07 42 4D 63 03 83 01 01 86</p> <p>Note: Set the pH high alarm value to: 0x04B0→1200→12.00, the set high pH high alarm value data is 100 times of the actual value, this indicates that the set pH high alarm value is pH12.00. Set the pH low alarm value to: 0x00C8→200→2.00, the set low pH high alarm value data is 100 times of the actual value, this indicates that the set pH high alarm value is pH2.00. Setting status: 0x01→1, this indicates that the setting is successful. After the pH low alarm signal is triggered, the pH value to stop the alarm requires to be higher than the set pH low alarm value by 0.03. For example, if the pH low alarm value is 0x00C8→200→pH2.00, the pH value to stop the alarm requires to be greater than or equal to the pH value: 0x00CC→204→pH2.04. After the pH low alarm signal is triggered, the pH value to stop the alarm requires to be less than the set pH high alarm value by 0.03. For example, if the pH low alarm value is 0x04B0→1200→pH12.00, the pH value to stop the alarm requires to be less than or equal to the pH value: 0x04AC→1196→pH11.96. It is recommended that the pH high alarm value is greater than the pH low alarm value by 0.08. The alarm function cannot be turned off.</p>				
Read pH alarm value (0x04)	Master write to Module	None	—	—
	Master read from Module	DATA[0]	pH high alarm value higher eight bits (bit8~bit15)	pH high alarm value: 1~1400 (0.01~14.00) The pH high alarm value is greater than the pH low alarm value
		DATA[1]	pH high alarm value lower eight bits (bit0~bit7)	
		DATA[2]	pH low alarm value higher eight bits (bit8~bit15)	pH low alarm value: 0~1399 (0.00~13.99) pH low alarm value is less than pH high alarm value
		DATA[3]	pH low alarm value lower eight bits (bit0~bit7)	

Master Command Code (HCMD)	Data (DATA)	Description	Range (DEC)	
<p>Example:  Master write to Module (HEX): 06 42 4D 63 03 04 00 07  Master read from Module (HEX): 07 42 4D 63 03 84 04 04 <b>04 B0 00 C8 0B</b></p> <p>Note:  Read the pH high alarm value to: <b>0x04B0</b>→1200→12.00, the read pH high alarm value data is 100 times of the actual value, this indicates that the read pH high alarm value is pH12.00. The factory default value for pH high alarm value is: 0x0578→1400→14.00, this indicates that the factory default value for pH high alarm value is pH14.00.  Read the pH low alarm value to: <b>0x00C8</b>→200→2.00, the read pH low alarm value data is 100 times of the actual value, this indicates that the read pH low alarm value is pH2.00. The factory default value for pH low alarm value is: 0x0000→0→0.00, this indicates that the factory default value for pH low alarm value is pH0.00.</p>				
Sleep (0x05)	Master write to Module	None	—	—
	Master read from Module	None	—	—
<p>Example:  Master write to Module (HEX): 06 42 4D 63 03 05 00 06  Master read from Module (HEX): 07 42 4D 63 03 85 00 86</p>				
Reset (0x06)	Master write to Module	None	—	—
	Master read from Module	None	—	—
<p>Example:  Master write to Module (HEX): 06 42 4D 63 03 06 00 05  Master read from Module (HEX): 07 42 4D 63 03 86 00 85  The module returns data before reset.</p>				
Read module status (0x09)	Master write to Module	None	—	—
	Master read from Module	DATA[1]	pH4.00 calibration data status	1: Calibration data is normal 0: Calibration data is abnormal
		DATA[2]	pH6.86 calibration data status	1: Calibration data is normal 0: Calibration data is abnormal
		DATA[3]	pH9.18 calibration data status	1: Calibration data is normal 0: Calibration data is abnormal
		DATA[4]	Temperature detection status	0: Invalid 1: Temperature detection is normal 2: Exceeding temperature detection range 3: NTC interface short circuit 4: NTC interface open circuit

Master Command Code (HCMD)	Data (DATA)	Description	Range (DEC)
<p>Example: Master write to Module (HEX): 06 42 4D 63 03 09 00 02 Master read from Module (HEX): 07 42 4D 63 03 89 05 01 01 01 01 78</p> <p>Note: pH4.00 calibration data status: 0x01→1, this indicates that the pH4.00 calibration data is normal. pH6.86 calibration data status: 0x01→1, this indicates that the pH6.86 calibration data is normal. pH9.18 calibration data status: 0x01→1, this indicates that the pH9.18 calibration data is normal. Temperature detection status: 0x01→1, this indicates that the temperature detection is normal. The temperature detection status data read within 5s from V<sub>DD</sub>≥3.0V and 5s from wake-up is invalid.</p>			
Calibrate NTC R25 (0x0A)	Master write to Module	None	—
	Master read from Module	DATA[0]	NTC type
		DATA[1]	Calibration status
<p>1: The B value of NTC is 3950 10K 2: The B value of NTC is 3435 10K 1: 25°C calibration succeeded 0: 25°C calibration failed</p>			
<p>Example: Master write to Module (HEX): 06 42 4D 63 03 0A 00 01 Master read from Module (HEX): 07 42 4D 63 03 8A 02 01 01 7D</p> <p>Note: The NTC type used by the module: 0x01→1, this indicates that the B value of NTC used by the module is 3950 10K. Calibration status: 0x01→1, this indicates that 25°C calibration succeeded.</p>			
Read the slope of the pH electrode during calibration (0x0E)	Master write to Module	None	—
	Master read from Module	DATA[0]	The slope of the electrode between pH4.00~pH6.86
		DATA[1]	The slope of the electrode between pH6.86~pH9.18
<p>— —</p>			
<p>Example: Master write to Module (HEX): 06 42 4D 63 03 0E 00 FD Master read from Module (HEX): 07 42 4D 63 03 8E 02 62 61 B8</p> <p>Note: The slope of the electrode between pH4.00~pH6.86: 0x62→98→98%, the output data of the module is 100 times the actual value, this indicates that the slope of the electrode between pH4.00~pH 6.86 is 98%. The slope of the electrode between pH6.86~pH9.18: 0x61→97→97%, the output data of the module is 100 times the actual value, this indicates that the slope of the electrode between pH6.86~pH9.18 is 97%.</p>			
Set the NTC type used by the module (0x0F)	Master write to Module	DATA[0]	NTC type
	Master read from Module	DATA[0]	Setting status
<p>1: The B value of NTC is 3950 10K 2: The B value of NTC is 3435 10K 1: Setting succeeded 0: Setting failed</p>			
<p>Example: Master write to Module (HEX): 06 42 4D 63 03 0F 01 01 FA Master read from Module (HEX): 07 42 4D 63 03 8F 01 01 7A</p> <p>Note: Set the NTC type used by the module: 0x01→1, this indicates that the B value of the set NTC used by the module is 3950 10K. Setting status: 0x01→1, this indicates that setting succeed.</p>			

Master Command Code (HCMD)	Data (DATA)		Description	Range (DEC)
Read the NTC type used by the module (0x10)	Master write to Module	None	—	—
	Master read from Module	DATA[0]	NTC type	1: The B value of NTC is 3950 10K 2: The B value of NTC is 3435 10K
Example: Master write to Module (HEX): 06 42 4D 63 03 10 00 FB Master read from Module (HEX): 07 42 4D 63 03 90 01 01 79 Note: Read the NTC type used by the module: 0x01→1, this indicates that the B value of the read NTC used by the module is 3950 10K.				
Clear the NTC R25 calibration value (0x11)	Master write to Module	None	—	—
	Master read from Module	DATA[0]	NTC type	1: The B value of NTC is 3950 10K 2: The B value of NTC is 3435 10K
Example: Master write to Module (HEX): 06 42 4D 63 03 10 00 FA Master read from Module (HEX): 07 42 4D 63 03 91 01 01 78 Note: NTC type that clears the 25°C calibration value: 0x01→1, this indicates that the B value of NTC type that clears the 25°C calibration value is 3950 10K.				

Note: It must be noted that if users do not send commands according to specifications, incorrect values may be received.

## UART Interface

### UART Communication Protocol

In the UART communication mode, the BM25S4421-1 communication is implemented in a fixed communication format. Refer to the following contents for protocol details.

### Host Send Frame Format

Baud rate: 9600, 8-N-1

Frame Header 0x42,0x4D	Module Categories 0x63	ID Code Initial: 0x03	Host Command Code (HCMD)	Length (LEN)	Data (DATA)	Checksum (CS)
2-byte	1-byte	1-byte	1-byte	1-byte	n-byte	1-byte

- ◆ Length (LEN)=number of Data (DATA) bytes
- ◆ Checksum (CS)=~(Frame Header+Module Categories+ID Code+Host Command Code+Length+Data Code)+1

### Module Return Frame Format

Baud rate: 9600, 8-N-1

Frame Header 0x42,0x4D	Module Categories 0x63	ID Code Initial:0x03	Module Command Code (MCMD)	Length (LEN)	Data (DATA)	Checksum (CS)
2-byte	1-byte	1-byte	1-byte	1-byte	n-byte	1-byte

- ◆ Length (LEN)=number of Data (DATA) bytes
- ◆ Module Command Code (MCMD)= Host Command Code (HCMD)+0x80
- ◆ Checksum (CS)=~(Frame Header+Module Categories+ID Code+Module Command Code+Length+Data Code)+1

### Command Description

Host Command Code (HCMD)	Data (DATA)		Description	Range (DEC)
Set the module ID (0x00)	Host send	DATA[0]	Module ID to be set	Module ID value: 1~127
	Module return	DATA[0]	Setting status	1: Succeeded 0: Failed
<p>Example: Host send (HEX): 42 4D 63 03 00 01 <b>30</b> DA Module return (HEX): 42 4D 63 30 80 01 <b>01</b> 5C</p> <p>Note: Module ID value: <b>0x30</b>→48, the module ID is set to 48. Setting status: <b>0x01</b>→1, this indicates that the module ID is set successfully.</p>				
Read the pH value and temperature value (0x01)	Host send	None	—	—
	Module return	DATA[0]	pH value higher eight bits (bit8~bit15)	0~1400 (0.00~14.00) 1500: pH data is greater than the measurement upper limit
		DATA[1]	pH value lower eight bits (bit0~bit7)	65436: pH data is lower than the measurement lower limit
		DATA[2]	Temperature value higher eight bits (bit8~bit15)	0~600 (0.0°C~60.0°C)
	DATA[3]	Temperature value lower eight bits (bit0~bit7)	1500: NTC interface short 65036: NTC Interface open	
<p>Example: Host send (HEX): 42 4D 63 03 01 00 0A Module return (HEX): 42 4D 63 03 81 04 <b>02 BC 00 FA CE</b></p> <p>Note: The pH data and temperature data read within 5s from <math>V_{DD} \geq 3.0V</math> or 5s from wake-up is invalid. pH value: <b>0x02BC</b>→700→pH7.00, the module output pH value data is 100 times of the actual value, this indicates that the read pH value is 7.00 If the pH value is 0x05DC (1500) this indicates that the pH data is greater than the measurement upper limit. If the pH value is 0xFF9C (65436), this indicates that the pH data is less than the measurement lower limit. When the module has not calibrated pH4.00 or pH6.86 or pH9.18, the pH value read is 0x0000→0→pH0.00. Temperature value: <b>0x00FA</b>→250→25.0°C, the module output temperature value data is 100 times of the actual value, this indicates that that the read temperature value is 25.0°C. If the temperature value is 0x05DC (1500), this indicates that the NTC interface is short. If the temperature is 0xFE0C (65036), this indicates that the NTC interface is open. When the measured temperature is greater than 60°C, the temperature value is 0x0258→600→60.0°C. When the measured temperature is less than 0°C, the temperature value is 0x00→0→0.0°C.</p>				
Calibrate the pH (0x02)	Host send	None	—	—
	Module return	DATA[0]	pH type to be calibrated	0: Invalid 1: Calibrate pH4.00 2: Calibrate pH6.86 3: Calibrate pH9.18
		DATA[1]	Calibration Status	1: Succeeded 0: Failed
<p>Example: Host send (HEX): 42 4D 63 03 02 00 09 Module return (HEX): 42 4D 63 03 82 02 <b>01 01</b> 85</p> <p>Note: pH type to be calibrated: <b>0x01</b>→1, this indicates that the pH type to be calibrated is pH4.00. Calibration Status: <b>0x01</b>→1, this indicates that the calibration is successful. If the calibration has failed, the old calibration value will not be cleared.</p>				

Host Command Code (HCMD)	Data (DATA)		Description	Range (DEC)
Set the pH alarm value (0x03)	Host send	DATA[0]	pH high alarm value higher eight bits (bit8~bit15)	pH high alarm value: 1~1400(0.01~14.00) The pH high alarm value is greater than the pH low alarm value
		DATA[1]	pH high alarm value lower eight bits (bit0~bit7)	
		DATA[2]	pH low alarm value higher eight bits (bit8~bit15)	pH low alarm value: 0~1399(0.00~13.99) The pH low alarm value is less than the pH high alarm value
		DATA[3]	pH low alarm value lower eight bits (bit0~bit7)	
	Module return	DATA[0]	Setting status	1: Succeeded 0: Failed
<p>Example:</p> <p>Host send (HEX): 42 4D 63 03 03 04 04 B0 00 C8 88</p> <p>Module return (HEX): 42 4D 63 03 83 01 01 86</p> <p>Note:</p> <p>Set the pH high alarm value to: 0x04B0→1200→12.00, the set high pH high alarm value data is 100 times of the actual value, this indicates that the set pH high alarm value is pH12.00.</p> <p>Set the pH low alarm value to: 0x00C8→200→2.00, the set low pH high alarm value data is 100 times of the actual value, this indicates that the set pH high alarm value is pH2.00.</p> <p>Setting status: 0x01→1, this indicates that the setting is successful.</p> <p>After the pH low alarm signal is triggered, the pH value to stop the alarm requires to be higher than the set pH low alarm value by 0.03. For example, if the pH low alarm value is 0x00C8→200→pH2.00, the pH value to stop the alarm requires to be greater than or equal to the pH value: 0x00CC→204→pH2.04.</p> <p>After the pH low alarm signal is triggered, the pH value to stop the alarm requires to be less than the set pH high alarm value by 0.03. For example, if the pH low alarm value is 0x04B0→1200→pH12.00, the pH value to stop the alarm requires to be less than or equal to the pH value: 0x04AC→1196→pH11.96.</p> <p>It is recommended that the pH high alarm value is greater than the pH low alarm value by 0.08.</p> <p>The alarm function cannot be turned off.</p>				
Read the pH alarm value (0x04)	Host send	None	—	—
	Module return	DATA[0]	pH high alarm value higher eight bits (bit8~bit15)	pH high alarm value: 1~1400 (0.01~14.00) The pH high alarm value is greater than the pH low alarm value
		DATA[1]	pH high alarm value lower eight bits (bit0~bit7)	
		DATA[2]	pH low alarm value higher eight bits (bit8~bit15)	pH low alarm value: 0~1399 (0.00~13.99) pH low alarm value is less than pH high alarm value
		DATA[3]	pH low alarm value lower eight bits (bit0~bit7)	
<p>Example:</p> <p>Host send (HEX): 42 4D 63 03 04 00 07</p> <p>Module return (HEX): 42 4D 63 03 84 04 04 B0 00 C8 0B</p> <p>Note:</p> <p>Read the pH high alarm value to: 0x04B0→1200→12.00, the read pH high alarm value data is 100 times of the actual value, this indicates that the read pH high alarm value is pH12.00. The factory default value for pH high alarm value is: 0x0578→1400→14.00, this indicates that the factory default value for pH high alarm value is pH14.00.</p> <p>Read the pH low alarm value to: 0x00C8→200→2.00, the read pH low alarm value data is 100 times of the actual value, this indicates that the read pH low alarm value is pH2.00. The factory default value for pH low alarm value is: 0x0000→0→0.00, this indicates that the factory default value for pH low alarm value is pH0.00.</p>				
Sleep (0x05)	Host send	None	—	—
	Module return	None	—	—
<p>Example:</p> <p>Host send (HEX): 42 4D 63 03 05 00 06</p> <p>Module return (HEX): 42 4D 63 03 85 00 86</p>				

Host Command Code (HCMD)	Data (DATA)		Description	Range (DEC)
Reset (0x06)	Host send	None	—	—
	Module return	None	—	—
Example: Host send (HEX): 42 4D 63 03 06 00 05 Module return (HEX): 42 4D 63 03 86 00 85 Note: Module returns data before reset.				
Read the module status(0x09)	Host send	None	—	—
	Module return	DATA[1]	pH4.00 calibration data status	1: Calibration data is normal 0: Calibration data is abnormal
		DATA[2]	pH6.86 calibration data status	1: Calibration data is normal 0: Calibration data is abnormal
		DATA[3]	pH9.18 calibration data status	1: Calibration data is normal 0: Calibration data is abnormal
DATA[4]		Temperature detection status	0: Invalid 1: Temperature detection is normal 2: Exceeding temperature detection range 3: NTC interface short circuit 4: NTC interface open circuit	
Example: Host send (HEX): 42 4D 63 03 09 00 02 Module return (HEX): 42 4D 63 03 89 05 01 01 01 01 01 78 Note: pH4.00 calibration data status: 0x01→1, this indicates that the pH4.00 calibration data is normal. pH6.86 calibration data status: 0x01→1, this indicates that the pH6.86 calibration data is normal. pH9.18 calibration data status: 0x01→1, this indicates that the pH9.18 calibration data is normal. Temperature detection status: 0x01→1, this indicates that the temperature detection is normal. The temperature detection status data read within 5s from $V_{DD} \geq 3.0V$ and 5s from wake-up is invalid.				
Calibrate NTC R25 (0x0A)	Host send	None	—	—
	Module return	DATA[0]	NTC type	1: The B value of NTC is 3950 10K 2: The B value of NTC is 3435 10K
DATA[1]		Calibration Status	1: 25°C calibration succeeded 0: 25°C calibration failed	
Example: Host send (HEX): 42 4D 63 03 0A 00 01 Module return (HEX): 42 4D 63 03 8A 02 01 01 7D Note: The NTC type used by the module: 0x01→1, this indicates that the B value of NTC used by the module is 3950 10K. Calibration status: 0x01→1, this indicates that 25°C calibration succeeded.				
Read the slope of the pH electrode during calibration (0x0E)	Host send	None	—	—
	Module return	DATA[0]	The slope of the electrode between pH4.00~pH6.86	—
DATA[1]		The slope of the electrode between pH6.86~pH9.18	—	

Host Command Code (HCMD)	Data (DATA)	Description	Range (DEC)
<p>Example:            Host send (HEX): 42 4D 63 03 0E 00 FD            Module return (HEX): 42 4D 63 03 8E 02 62 61 B8</p> <p>Note:            The slope of the electrode between pH4.00~pH6.86: 0x62→98→98%, the output data of the module is 100 times the actual value, this indicates that the slope of the electrode between pH4.00~pH 6.86 is 98%.            The slope of the electrode between pH6.86~pH9.18: 0x61→97→97%, the output data of the module is 100 times the actual value, this indicates that the slope of the electrode between pH6.86~pH9.18 is 97%.</p>			
Set the NTC type used by the module (0x0F)	Host send	DATA[0] NTC type	1: The B value of NTC is 3950 10K 2: The B value of NTC is 3435 10K
	Module return	DATA[0] Setting status	1: Succeeded 0: Failed
<p>Example:            Host send (HEX): 42 4D 63 03 0F 01 01 FA            Module return (HEX): 42 4D 63 03 8F 01 01 7A</p> <p>Note:            Set the NTC type used by the module: 0x01→1, this indicates that the B value of the set NTC used by the module is 3950 10K.            Setting status: 0x01→1, this indicates that setting succeed.</p>			
Read the NTC type used by the module (0x10)	Host send	None	—
	Module return	DATA[0] NTC type	1: The B value of NTC is 3950 10K 2: The B value of NTC is 3435 10K
<p>Example:            Host send (HEX): 42 4D 63 03 10 00 FB            Module return (HEX): 42 4D 63 03 90 01 01 79</p> <p>Note:            Read the NTC type used by the module: 0x01→1, this indicates that the B value of the read NTC used by the module is 3950 10K.</p>			
Clear the NTC R25 calibration value (0x11)	Host send	None	—
	Module return	DATA[0] NTC type	1: The B value of NTC is 3950 10K 2: The B value of NTC is 3435 10K
<p>Example:            Host send (HEX): 42 4D 63 03 11 00 FA            Module return (HEX): 42 4D 63 03 91 01 01 78</p> <p>Note:            NTC type that clears the 25°C calibration value: 0x01→1, this indicates that the B value of NTC type that clears the 25°C calibration value is 3950 10K.</p>			

Note: It must be noted that if users do not send commands according to specifications, users may receive incorrect values.

## Application Circuits

### I<sup>2</sup>C Mode

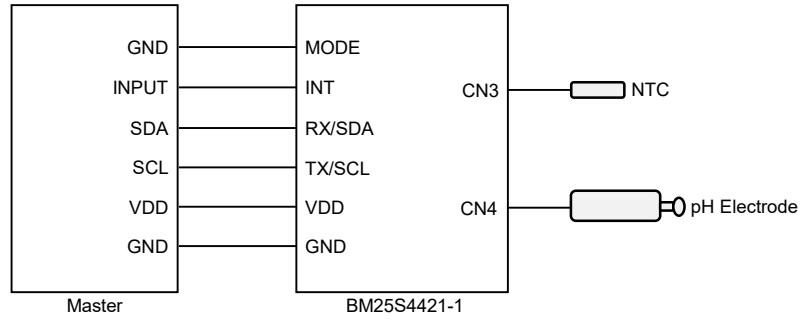

### UART Mode

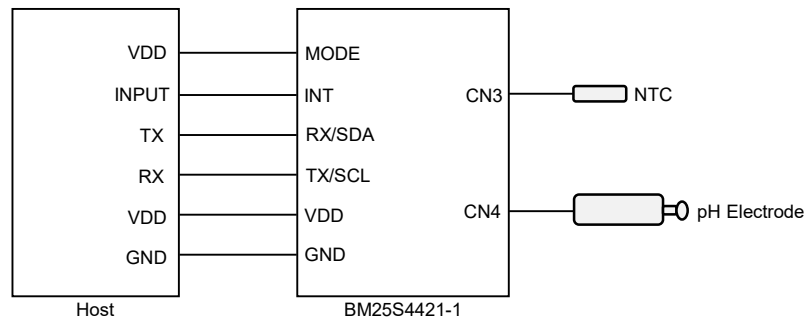

## Dimensions

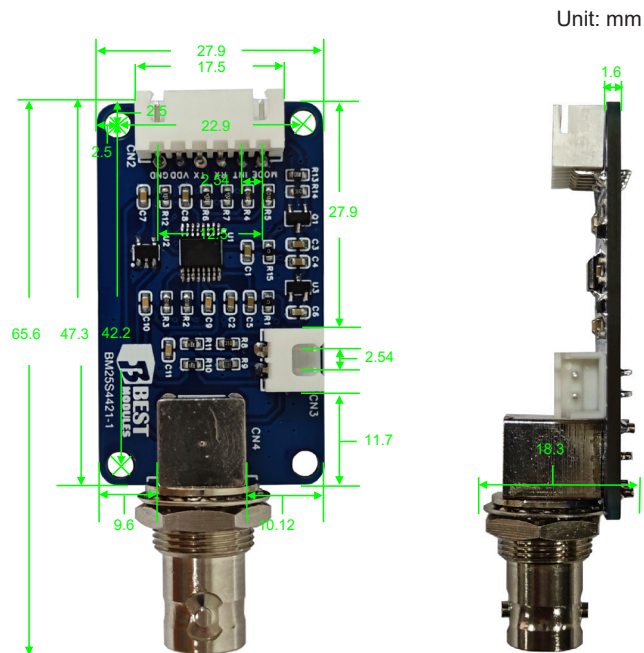

## Reference Information

### Modification History

Data	Author	Issue	Modification Information
2023.06.06	邱安镇	V1.00	First Version
2024.08.27	邱安镇	V1.10	(1) Add the module feature description (2) Modify the General Description (3) Add the Pin Description (4) Add the pH electrode description

### Buy Online

[Best Modules](#)

Copyright© 2024 by BEST MODULES CORP. All Rights Reserved.

The information provided in this document has been produced with reasonable care and attention before publication, however, BEST MODULES does not guarantee that the information is completely accurate. The information contained in this publication is provided for reference only and may be superseded by updates. BEST MODULES disclaims any expressed, implied or statutory warranties, including but not limited to suitability for commercialization, satisfactory quality, specifications, characteristics, functions, fitness for a particular purpose, and non-infringement of any third-party's rights. BEST MODULES disclaims all liability arising from the information and its application. In addition, BEST MODULES does not recommend the use of BEST MODULES' products where there is a risk of personal hazard due to malfunction or other reasons. BEST MODULES hereby declares that it does not authorize the use of these products in life-saving, life-sustaining or safety critical components. Any use of BEST MODULES' products in life-saving/sustaining or safety applications is entirely at the buyer's risk, and the buyer agrees to defend, indemnify and hold BEST MODULES harmless from any damages, claims, suits, or expenses resulting from such use. The information provided in this document, including but not limited to the content, data, examples, materials, graphs, and trademarks, is the intellectual property of BEST MODULES (and its licensors, where applicable) and is protected by copyright law and other intellectual property laws. No license, express or implied, to any intellectual property right, is granted by BEST MODULES herein. BEST MODULES reserves the right to revise the information described in the document at any time without prior notice. For the latest information, please contact us.