

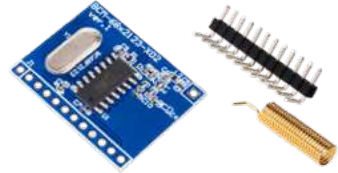

1 Accessory List

- 1.Parallel type RF wireless receiving module - BCM-68F2123-X02 ×1
2. Spring antenna - 433.92MHz Antenna × 1
3. 90° pin header with 12 pins × 1



2 Component Description and Layout

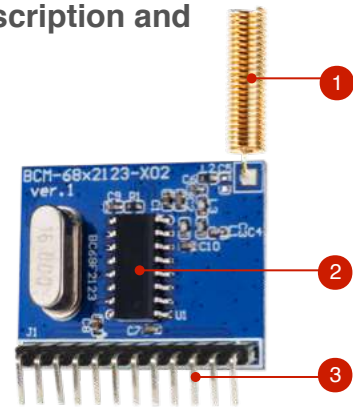

- 1 Spring antenna
- 2 BC68F2123
- 3 Pin header

3 Pin Order



Pin #	Pin Name	Description
1	GND	GND
2	VDD	VDD
3	VDDRF	VDDRF
4	OCSDA	PA0
5	OCDSCK	PA2
6	TX_LED	PB1
7	KEY1	PA1
8	KEY2	PA5
9	KEY3	PA6
10	KEY4	PA7
11	Reserved1	PB0
12	Reserved2	PB5

4 Product Description

This product uses a custom transmitting signal protocol and should therefore be used together with the following module products:

- Evaluation board: BCE-GENTX-X01
- Parallel type 433MHz RF receiving module: BCM-68F2420-C01
- Serial type 433MHz RF receiving module: BCM-2401-C03

The above products need to be purchased separately, refer to the "Appendix 1: Product System Diagram".

5 Functional Description

- 1.The product operating frequency is 433.92MHz.
- 2.As the Master MCU, a BC68F2123, includes the required program, user programming is not necessary.
- 3.Refer to "Appendix 2: HT OOK demo board package format" for detailed information about the RF transmission package content.

6 Solder the antenna and pin header first

Note: The antenna must be placed vertically and kept away from metallic objects.

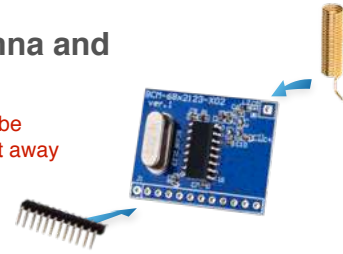

7 Insert the module into the socket on the evaluation board, which needs to be purchased separately.

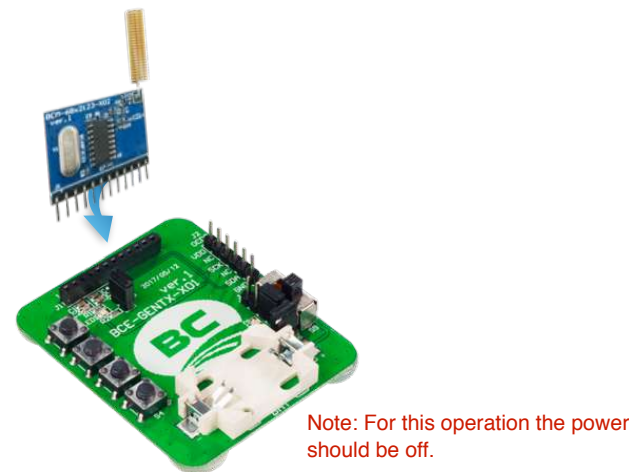

Note: For this operation the power should be off.

8 Insert battery

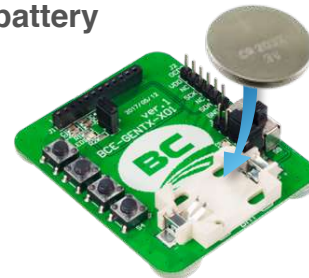

9 Switch on the power

The power indicator LED2 will illuminate.



→ on

10 Signal Transmission and Indication

Pressing any key on the evaluation board will transmit the corresponding RF signal, the signal transmitting indicator LED1 will illuminate. The RF wireless transmitting board will transmit the corresponding data packet more than twice each time the key is pressed. Releasing the key will stop transmission and the LED1 will be off.



Note: The key should be pressed and held for at least 40ms to avoid the system ignoring the key press action.

11 Power Down Mode

The signal transmission will stop and the LED indicator will be off after the key is released, the product will then enter the power down mode automatically.



12 Block Diagram



13 Circuit Schematic

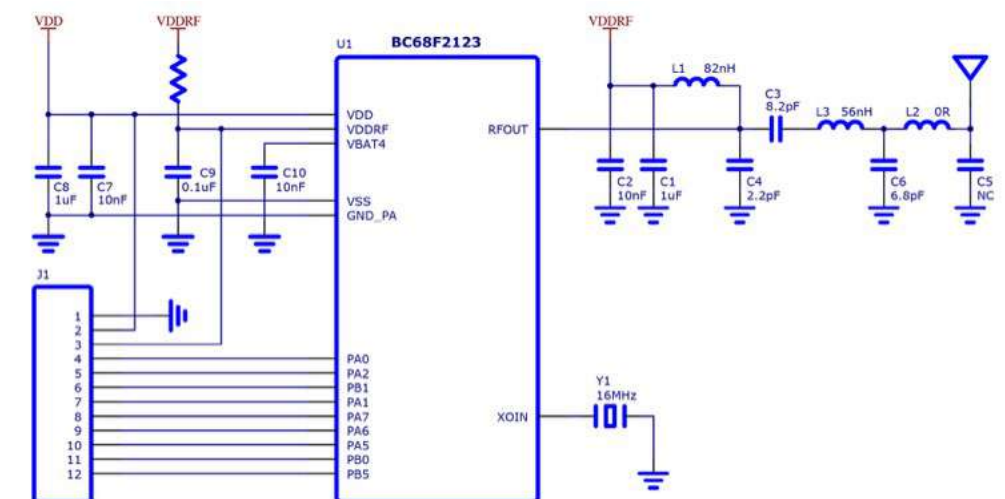



16 Appendix 1: Product System Diagram

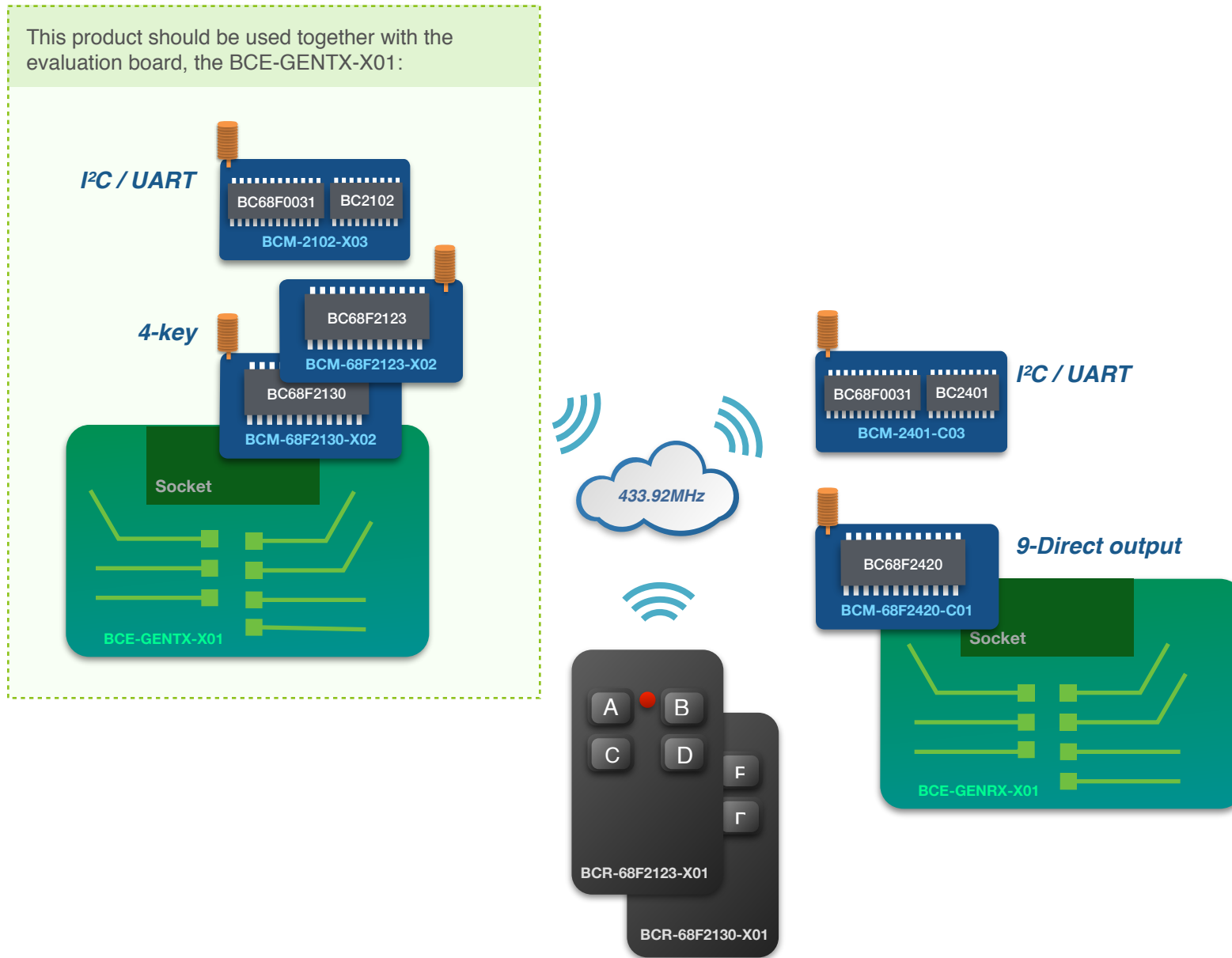

17 Appendix 2: HT OOK demo board package format

The "code word" is a group of code bits used in OOK wireless communication. This document describes the code word format used in HT OOK demo boards. A code word consists of leading code, start code, address, data, CRC and end code. Each fields are composed with several symbols. The symbol rate is set as 5Kbps. Each symbol (λ) in table below is 200us.

A. Leading Code + Start code

Leading code: Repeating 1 λ high and 1 λ low for 8 times. Start code: 4 λ high + 2 λ low



B. Address, data & CRC

Each bit is composed with 4 symbols. The format for bit "0" and "1" are shown below:

Bit "0" → 1 λ high + 3 λ low Bit "1" : 3 λ high + 1 λ low



For TX demo boards / remote controllers, their addresses are pre-programmed in the MCU program ROM. Users do not need to specify the address.

For RX demo boards, they have to be paired with a TX first before being used. The pairing process allows the RX recognize the TX and memorize TX's address in its non-volatile memory.

$$CRC = X^8 + X^5 + X^4 + 1$$

Below shows the data when K1~K4 is pressed down

	D7	D6	D5	D4	D3	D2	D1	D0
K1	0	0	0	0	0	0	0	1
K2	0	0	0	0	0	0	1	0
K3	0	0	0	0	0	1	0	0
K4	0	0	0	0	1	0	0	0

C. End code: 2 λ high + 2 λ low

End code is used to separate the sequent two code words.

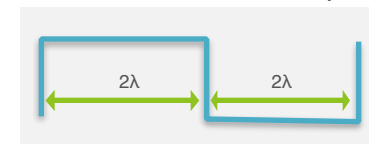

The code word format is like:

	Leading	Start	Address	Data	CRC	END
length	16 λ	6 λ	4 λ /bit*24bit	4 λ /bit*8bit	4 λ /bit x 8bit	4 λ

The total length for a code word is 200us x (16+6+96+32+32+4) = 37.2ms

Hyper link

BC68F0031

BC68F2123

BC68F2130

BC68F2420

BC2401

BC2102