



**MEMS Alcohol Digital Sensor**

**BM22S3421-1**

Revision: V1.00 Date: September 21, 2023

## Table of Contents

<b>Features</b> .....	<b>3</b>
<b>General Description</b> .....	<b>3</b>
<b>Applications</b> .....	<b>3</b>
<b>Selection Table</b> .....	<b>3</b>
<b>Block Diagram</b> .....	<b>4</b>
<b>Pin Assignment</b> .....	<b>4</b>
<b>Pin Description</b> .....	<b>4</b>
<b>Absolute Maximum Ratings</b> .....	<b>5</b>
<b>D.C. Electrical Characteristics</b> .....	<b>5</b>
<b>Functional Description</b> .....	<b>5</b>
Solution Introduction .....	5
Operation Flow.....	5
Gas Sensor Characteristics .....	6
Application Circuits.....	6
<b>Interface Description</b> .....	<b>7</b>
Alarm Status Level Output Interface .....	7
UART Serial Communication Interface .....	7
<b>UART Serial Communication</b> .....	<b>7</b>
UART Transmit and Receive Data Format.....	7
TX Pin Serial Interface Automatic Output Data Format.....	7
UART Data Transmission Format .....	8
UART Communication Instruction Set Summary .....	9
<b>Considerations</b> .....	<b>16</b>
Usage Description.....	16
Situations that Must Be Avoided .....	16
Situations to be Avoided.....	16
<b>Dimensions</b> .....	<b>17</b>

## Features

- Operating voltage: 3.0~5.0V
- Operating current: About 17mA @ 3.3V
- Detection alcohol concentration level: Level 1 ~ Level 4  
(The corresponding concentration is from low to high)
- Detection range: 0~400PPM
- Interfaces: UART (TX/RX)/STATUS
- Communication mode: UART/STATUS
- Communication interface baud rate: 9600bps
- Default alarm threshold: Level 3
- Factory calibration, default warm-up time: 180s



## General Description

The BM22S3421-1 is a MEMS alcohol digital sensor, which includes an integrated MCU as the master device with a serial communication mode, which can offer widespread and convenient use. The sensor has the advantages of small size, convenience of integration into product applications, long service life, easy operation, requiring no external drive circuit, low cost, etc. It is a digital sensor specially designed for alcohol detection applications and suitable for use in air quality monitors, IoT devices, chemical plant monitors, etc.

## Applications

- Air quality monitors
- IoT devices
- Chemical plant monitors

## Selection Table

Part No.	Gas Type	Detection Alcohol Concentration Level	Interface
BM22S3421-1	Alcohol (C <sub>2</sub> H <sub>5</sub> OH)	Level 1 ~ Level 4 (The corresponding concentration is from low to high)	UART (TX/RX)/STATUS

## Block Diagram

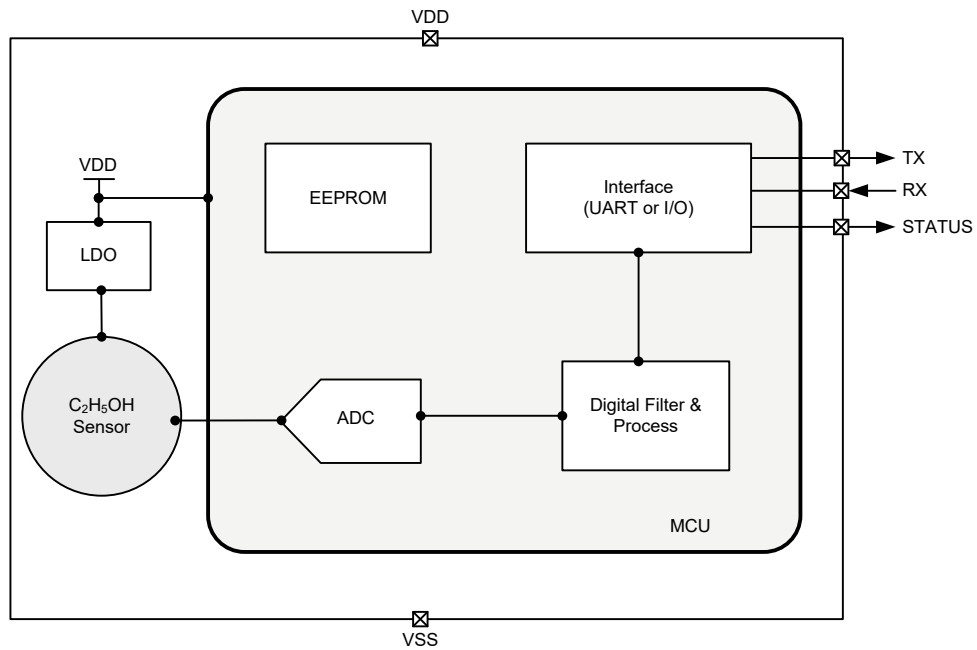

## Pin Assignment

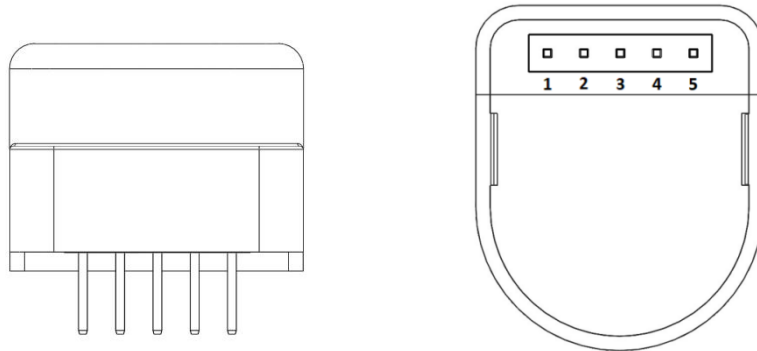

## Pin Description

Pin Number	Pin Name	Type	Description
1	VDD	PWR	Sensor module power input (3~5V)
2	VSS	PWR	Ground
3	RX	ST	UART RX serial data input – baud rate 9600bps
4	TX	CMOS	UART TX serial data output – baud rate 9600bps
5	STATUS	O	Alarm level output – default output low in non-alarm status

Legend: O: Digital output;  
 PWR: Power;

ST: Schmitt Trigger input;  
 CMOS: CMOS output

## Absolute Maximum Ratings

Supply Voltage .....	$V_{SS}-0.1V$ to $V_{SS} + 5.1V$
Input Voltage .....	$V_{SS}-0.1V$ to $V_{DD}+0.1V$
Storage Temperature.....	-40 °C to 85 °C
Operating Temperature.....	-10 °C to 50 °C
Total Power Dissipation .....	100mW

Note: These are stress ratings only. Stresses exceeding the range specified under “Absolute Maximum Ratings” may cause substantial damage to the sensor. Functional operation of the sensor at other conditions beyond those listed in the specification is not implied and prolonged exposure to extreme conditions may affect sensor reliability.

## D.C. Electrical Characteristics

Ta=25°C

Symbol	Parameter	Test Conditions		Min.	Typ.	Max.	Unit
		V <sub>DD</sub>	Conditions				
V <sub>DD</sub>	Operating Voltage	—	—	3.0	3.3	5.0	V
I <sub>DD</sub>	Operating Current	3.3V	—	—	17.0	—	mA

## Functional Description

### Solution Introduction

The BM22S3421-1 MEMS alcohol digital sensor includes an integrated MCU as the master device. As it uses a high accuracy gas sensor, when there is a certain concentration of alcohol gas in the environment where the sensor is located, the sensor will process the gas concentration signal and then transmit the processed data to an external MCU. The sensor module has two output modes. The first is the level output mode. Under normal conditions, the STATUS pin defaults to output low. When the gas concentration is detected to have reached the alarm point, the pin will change to a high level. The second is the serial interface mode, which is subdivided into serial interface automatic output mode and serial interface communication mode. In the serial interface automatic output mode, when the sensor operates normally, it will output the current sensor status every sampling period (about 1s) using the TX pin (baud rate 9600bps). The serial interface communication mode is implemented using the TX/RX pins using the UART communication instructions. In this way, the detailed sensor module status can be read using the TX pin and the sensor parameters such as warm-up time and alarm value can be modified using the RX pin. These two modes have their own special characteristics and can be chosen flexibly according to users’ requirements, the detailed usage of which can be obtained from the relevant interface section.

### Operation Flow

After the system is powered on, the BM22S3421-1 is initialised and warmed-up. The default warm-up time is 180s. After the warming-up is complete, the sensor enters the normal operation mode. In the normal operation mode, the sensor performs device status processing, sensor output sampling, fault detection and alarm detection in turn. Every sensor output sampling period (about 1s) the A/D value of the alcohol gas sensor can be obtained, which will be converted to the alcohol concentration level and automatically output using the serial interface along with the data such as device status and alcohol concentration level. When the UART receives a falling edge on the RX

pin, the sensor is woken up to enter the UART receive interrupt and perform UART instruction transmit and receive processing.

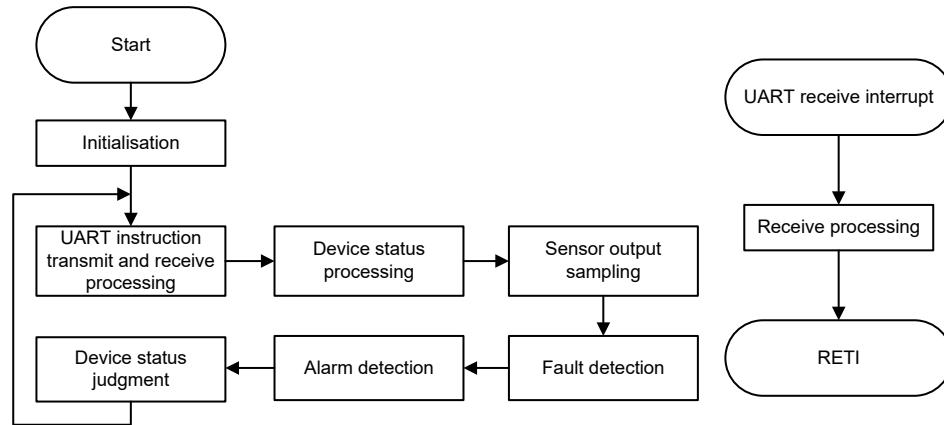

**BM22S3421-1 Operation Flowchart**

### Gas Sensor Characteristics

The MEMS alcohol digital sensor makes microthermal plates on Si-based substrates through the MEMS process. The used gas-sensitive material is a metal oxide semiconductor material which has lower conductivity in clean air. When an alcohol gas exists in the air, the sensor conductivity will increase according to the alcohol gas concentration increment. With this characteristic, a simple circuit is required to convert the conductivity change into output signals corresponding to the gas concentration through an A/D converter and a filter circuit.

### Application Circuits

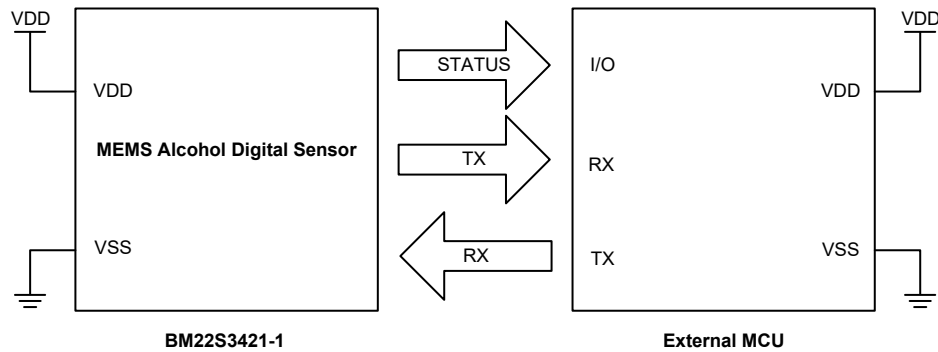

## Interface Description

### Alarm Status Level Output Interface

Under normal conditions, Pin 5, STATUS, defaults to low. When the sensor detects that the alcohol gas concentration in the environment has exceeded the preset alarm value (default alcohol concentration Level 3) and remains there for at least 3s, the sensor will enter the alarm status and the pin will change from low to high. When the alcohol gas concentration drops to the exit alarm concentration value (default alcohol concentration Level 1) and remains there for 3s, the pin will reset back to low.

### UART Serial Communication Interface

**TX pin automatic output data:** Under normal conditions, the TX pin will automatically output the sensor current operating status, real-time alcohol gas concentration A/D value, alcohol concentration level and other data every sampling period (about 1s).

**TX/RX pin serial interface communication:** The external MCU can configure or obtain sensor data using the UART serial communication port TX/RX, such as obtaining or setting the current alarm alcohol concentration level, obtaining or modifying the calibration value and warm-up time, etc.

## UART Serial Communication

The sensor RX pin will be at a high level under normal conditions. The external MCU sends data in the following format (UART transmit and receive data format) using the TX pin. The start bit of the data is low. A falling edge on the RX pin will wake up the MCU for UART communication processing.

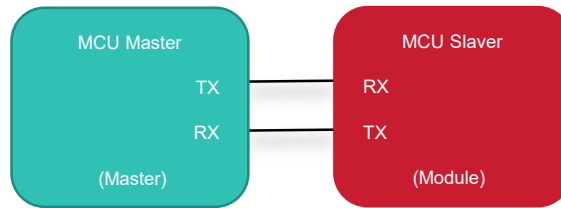

### UART Transmit and Receive Data Format

The UART transmit and receive data format is composed of a start bit, data bits and a stop bit. The sensor uses a baud rate of 9600bps for data transmission. The following diagram shows the waveform for UART data transmission and reception.

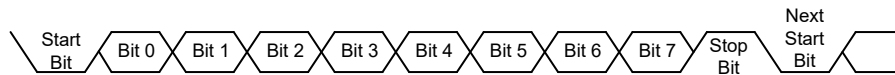

### TX Pin Serial Interface Automatic Output Data Format

When the module operates normally, every sampling period (about 1s) a frame of data will be output at a baud rate of 9600bps. Each data frame contains 14 bytes as shown in the following table. The data content is the same as the U1 instruction returned during UART communication.

Data Number	Data Content	Description	Data Number	Data Content	Description
0	0xAA	Fixed data	7	XX	Alcohol concentration level <sup>(2)</sup>
1	0x0E	Fixed data	8	XX	Alcohol sensor status <sup>(3)</sup>
2	0x42	Fixed data	9	XX	Calibrate timing <sup>(4)</sup>
3	0x01	Fixed data	10	XX	Warm-up timing <sup>(5)</sup>
4	0xAC	Fixed data	11	XX	Software version number high byte <sup>(6)</sup>
5	XX	Alcohol real-time A/D value high byte <sup>(1)</sup>	12	XX	Software version number low byte <sup>(6)</sup>
6	XX	Alcohol real-time A/D value low byte <sup>(1)</sup>	13	XX	Check code <sup>(7)</sup>

Note: 1. Alcohol real-time A/D value: The alcohol gas real-time A/D values is sampled by a 12-bit resolution A/D converter.

- Alcohol concentration grade: The current alcohol concentration level, the valid values are 1~4 (The corresponding concentration is from low to high). It is 0 if the device is warmed up and not calibrated. The sensor accuracy is affected by factors such as reference resistance difference, sensitivity difference, temperature, humidity, interfering gas, aging time and other factors. The sensor input-output has nonlinear, hysteresis and non-repeatable operating characteristics. Therefore, the alcohol concentration level is for reference only.
- Alcohol sensor status
  - bit\_0: If this bit is 1, it indicates that the sensor is calibrating.
  - bit\_1 ~ bit\_4: Reserved.
  - bit\_5: If this bit is 1, it indicates that the sensor calibration is complete.
  - bit\_6: If this bit is 1, it indicates that the sensor in a fault condition.
  - bit\_7: If this bit is 1, it indicates that the sensor in an alarm status.
- Calibration timing: Calibration countdown, unit is s. The default calibration time is 60s. A value of 0 indicates that the calibration is complete.
- Warm-up timing: Power-on warm-up countdown, unit is s. The warm-up time is 180s. A value of 0 indicates that the warm-up operating is complete.
- Software version number: If the software version number high byte is 0x10 and the software version number low byte is 0x02, the software version number is V1.0.2.
- Check code calculation method: Take the lower 8 bits of the sum of the first 13 bytes, complement and increment by one.

Example: If a frame of data received by the master using the serial interface is AA 0E 42 01 AC 02 FF 01 30 00 00 11 00 16.

It indicates that the device is warmed-up and has been calibrated. The current real-time A/D value is 767, the alcohol concentration level is Level 1 and the software version number is V1.1.0.

## UART Data Transmission Format

**Master sent data format:** The data frame sent by the master device consists of 4 bytes (fixed length), which are instruction, address, data and check code respectively. The related instruction definitions are different depending upon the slave device but fall into three categories, general instruction, special query instruction and special modification instruction. The general instructions are supported by all slave devices and mainly used to implement functions such as MCU reset, software version query, production date query, overall device status query and other functions. The special query and modification instructions are customised according to different device types. Each device has its own UART data instruction definitions, the details of which can be found in the relevant protocol.

**Check code:** Take the lower 8 bits of the sum of all data, complement and increment by one, the calculated result will then be known as the check code. For example if the instruction is 0xE0 0x1A 0x15, its check code is 0xF1.

Instruction	Address	Data	Check Code
8-bit	8-bit	8-bit	8-bit

**Slave returned data format:** The data returned from the slave device has variable length and mainly composed of instruction header, data length, device type, protocol version, return instruction, data 0 ~ data N and check code. The instruction header is fixed at 0xAA, the data length is the length from the instruction header to the check code (i.e., the length of all data). The device type is used to indicate what the current slave type is, the protocol version refers to the version of the UART communication protocol used by the current slave and the return instruction corresponds to the instruction sent by the master. Data 0 ~ Data N is the returned data under different instructions, the check code calculation method is the same as the master.

Instruction Header	Data Length	Device Type	Protocol Version	Return Instruction	Data 0	...	Data N	Check Code
8-bit	8-bit	8-bit	8-bit	8-bit	8-bit	...	8-bit	8-bit

### UART Communication Instruction Set Summary

Instruction type: The MEMS alcohol digital sensor BM22S3421-1 UART communication protocol contains three instruction types, general instruction, special query instruction and special modification instruction. There are 20 instructions in total, including 4 general instructions, 10 special query instructions and 6 special modification instructions. For their detailed contents and definitions, refer to the corresponding instruction description sections.

The general instruction number and function are as follows:

Instruction Type	Instruction Number	Instruction	Address	Instruction Function
General Instruction	U00	AF	00	Device reset
	U01	AC	00	Query all current device status and data
	U02	A0	00	Factory reset
	U03	AB	XX	Trigger the user calibration function

The special query instruction number and function are as follows:

Instruction Type	Instruction Number	Instruction	Address	Instruction Function
Special Query Instruction	R00	D0	1E	Query whether the current device serial interface data is automatically output
	R01	D0	1F	Query the current device alarm output level
	R02	D2	4F	Query the device status
	R03	D2	40	Query the alcohol A/D value (high byte)
	R04	D2	41	Query the alcohol A/D value (low byte)
	R05	D2	42	Query the concentration level
	R06	D0	1A	Query the alarm level
	R07	D0	1C	Query the alarm exit level
	R08	D0	1D	Query the warm-up setting time
	R09	D0	00	Query the calibration setting time

The special modification instruction number and function are as follows:

Instruction Type	Instruction Number	Instruction	Address	Instruction Function
Special Modification Instruction	W00	E0	1E	Modify the device serial interface automatic output status
	W01	E0	1F	Modify the device alarm output level
	W02	E0	1A	Modify the alarm level
	W03	E0	1C	Modify the alarm exit level
	W04	E0	1D	Modify the warm-up time
	W05	E0	00	Modify the calibration time

### General Instruction Description (U00~U03)

Instruction U00	Master	Instruction	Address	Data					Check Code
		AF	00	00					51
	Slave	Instruction Header	Data Length	Device Type	Protocol Version	Return Instruction	Return Address	Data	Check Code
	AA	08	42	01	AF	00	00	5C	

**Description:** Reset the device.  
The master sends AF 00 00 51 and the slave returns AA 08 42 01 AF 00 00 5C.

Instruction U01	Master	Instruction	Address	Data				Check Code
		AC	00	00				54
	Slave	Instruction Header	Data Length	Device Type	Protocol Version	Return Instruction	Alcohol Real-time A/D value	Concentration Level
		AA	0E	42	01	AC	XXXX	XX
		Alcohol Status		Calibration Timing	Warm-up Timing	Software Version Number	Check Code	
XX		XX	XX	XXXX	XX			

**Description:** Query all current device status and data.

**Byte 0~4: Fixed data header**

**Byte 5~6: Real-time A/D values**

The alcohol gas real-time A/D values is sampled by a 12-bit resolution A/D converter.

**Byte 7: Alcohol level**

The valid values are 1~4 (The corresponding concentration is from low to high). It is 0 if the device is warmed up and not calibrated.

**Byte 8: Alcohol status**

bit\_0: If this bit is 1, it indicates that the sensor is calibrating.

bit\_1 ~ bit\_4: Reserved.

bit\_5: If this bit is 1, it indicates that the sensor calibration is complete.

bit\_6: If this bit is 1, it indicates that the sensor is in a fault condition.

bit\_7: If this bit is 1, it indicates that the sensor is in an alarm status.

**Byte 9: Calibration timing**

Calibration countdown, unit is s. The default calibration time is 60s. A value of 0 indicates that the calibration is complete.

**Byte 10: Warm-up timing**

Power-on warm-up countdown, unit is s. The warm-up time is 180s. A value of 0 indicates that the warm-up operating is complete.

**Byte 11~12: Software version**

The master sends AC 00 00 54.

Instruction	Master	Instruction	Address	Data					Check Code
		A0	00	00					60
	Slave	Instruction Header	Data Length	Device Type	Protocol Version	Return Instruction	Return Address	Data	Check Code
	AA	08	42	01	A0	00	00	6B	

**Description:** Factory reset. After this instruction is sent, reset all parameter configurations to their factory settings. It is included as follows.  
 Alarm level: 3  
 Alarm exit level: 1  
 Warm-up time: 180s

**Example:** If the master sends A0 00 00 60 and the slave returns AA 08 42 01 A0 00 00 6B.  
 This indicates that a factory reset operation is performed and the factory calibration data is reloaded in the sensor.

Instruction	Master	Instruction	Address	Data					Check Code
		AB	XX	00					XX
	Slave	Instruction Header	Data Length	Device Type	Protocol Version	Return Instruction	Return Address	Data	Check Code
	AA	08	42	01	AB	XX	00	XX	

**Description:** Trigger the user calibration function to determine which calibration mode to use according to the address sent by the master.

**Calibration point 1:** Address 01 indicates that the calibration trigger point 1 (Level 1/2 judgment threshold)  
 The master sends AB 01 00 54 and the slave returns AA 08 42 01 AB 01 00 5F.

**Calibration point 2:** Address 02 indicates that the calibration trigger point 2 (Level 2/3 judgment threshold)  
 The master sends AB 02 00 53 and the slave returns AA 08 42 01 AB 02 00 5E.

**Calibration point 3:** Address 03 indicates that the calibration trigger point 3 (Level 3/4 judgment threshold)  
 The master sends AB 03 00 52 and the slave returns AA 08 42 01 AB 03 00 5D.

**Calibration check:** Address 06 will trigger the calibration check and update the calibration point 1~3 check value.  
 The master sends AB 06 00 4F and the slave returns AA 08 42 01 AB 06 00 5A.

Note: 1. There is no fixed order for calibration points 1~3, it can be calibrated in any order and 1~3 number. After the point calibration is completed, the calibration check instruction needs to be used, the device will enter the calibration completion state.  
 2. The calibration point must be set at calibration point 1 < calibration point 2 < calibration point 3, otherwise the output alcohol concentration level will have unpredictable errors.

**Special Query Instruction Description (R00~R09)**

Instruction	Master	Instruction	Address	Data					Check Code
		D0	1E	00					12
	Slave	Instruction Header	Data Length	Device Type	Protocol Version	Return Instruction	Return Address	Data	Check Code
	AA	08	42	01	D0	1E	XX	XX	

**Description:** Query whether the current device serial interface data output is enabled.  
 If the data is 0x08, this indicates that the serial interface output has been enabled and the serial interface will automatically output data once every detection period. If the data is 0x00, it indicates that serial interface output is not enabled.

**Example:** If the master sends D0 1E 00 12 and the slave returns AA 08 42 01 D0 1E 00 1D.  
 This indicates that the current device serial interface is not enabled and the sensor does not have a serial data output.

Instruction	Master	Instruction	Address	Data					Check Code
		D0	1F	00					11
	Slave	Instruction Header	Data Length	Device Type	Protocol Version	Return Instruction	Return Address	Data	Check Code
	AA	08	42	01	D0	1F	XX	XX	

**Description:** Query the current device alarm output level.  
 If the data is 0x08, the STATUS port outputs high when alarming and low under normal conditions. 00H is the opposite.

**Example:** If the master sends D0 1F 00 11 and the slave returns AA 08 42 01 D0 1F 08 14.  
 This indicates that the STATUS port outputs high when alarming and low under normal conditions.

Instruction	Master	Instruction	Address	Data					Check Code
		D2	4F	00					DF
	Slave	Instruction Header	Data Length	Device Type	Protocol Version	Return Instruction	Return Address	Data	Check Code
	AA	08	42	01	D2	4F	XX	XX	

**Description:** Query the current device status.  
 bit\_0: If this bit is 1, it indicates that the sensor is calibrating.  
 bit\_1 ~ bit\_4: Reserved.  
 bit\_5: If this bit is 1, it indicates that the sensor calibration is complete.  
 bit\_6: If this bit is 1, it indicates that the sensor calibration is in a fault state.  
 bit\_7: If this bit is 1, it indicates that the sensor in an alarm status.

**Example:** If the master sends D2 4F 00 DF and the slave returns AA 08 42 01 D2 4F 32 B8.  
 This indicates that the device is in a normal operating state.

Instruction	Master	Instruction	Address	Data					Check Code
		D2	40	00					EE
	Slave	Instruction Header	Data Length	Device Type	Protocol Version	Return Instruction	Return Address	Data	Check Code
	AA	08	42	01	D2	40	XX	XX	

**Description:** Query the alcohol A/D value (high byte).

**Example:** If the master sends D2 40 00 EE and the slave returns AA 08 42 01 D2 40 05 F4.  
 This indicates that the current alcohol A/D value high byte is 0x05.

Instruction	Master	Instruction	Address	Data					Check Code
		D2	41	00					ED
	Slave	Instruction Header	Data Length	Device Type	Protocol Version	Return Instruction	Return Address	Data	Check Code
	AA	08	42	01	D2	41	XX	XX	

**Description:** Query the alcohol A/D value (low byte).

**Example:** If the master sends D2 41 00 ED and the slave returns AA 08 42 01 D2 41 E5 13.  
 This indicates that the current alcohol A/D low byte is 0xE5, combined with the alcohol A/D value high byte read by R03 instruction, the current alcohol A/D value is 0x05E5 (1509).

Instruction R05	Master	Instruction	Address	Data					Check Code
		D2	42	00					EC
	Slave	Instruction Header	Data Length	Device Type	Protocol Version	Return Instruction	Return Address	Data	Check Code
AA	08	42	01	D2	42	XX	XX		

**Description:** Query the concentration level.  
**Example:** If the master sends D2 42 00 EC and the slave returns AA 08 42 01 D2 42 01 F6.  
This indicates that the current concentration level is Level 1.  
**Note:** The valid values are 1~4, which correspond to Level 1, Level 2, Level 3 and Level 4.

Instruction R06	Master	Instruction	Address	Data					Check Code
		D0	1A	00					16
	Slave	Instruction Header	Data Length	Device Type	Protocol Version	Return Instruction	Return Address	Data	Check Code
AA	08	42	01	D0	1A	XX	XX		

**Description:** Query the alarm level.  
The alarm level defaults to Level 3.  
**Example:** If the master sends D0 1A 00 16 and the slave returns AA 08 42 01 D0 1A 03 1E.  
This indicates that the current alarm Level is 3.  
**Note:** The valid values are 1~4, which correspond to Level 1, Level 2, Level 3 and Level 4.

Instruction R07	Master	Instruction	Address	Data					Check Code
		D0	1C	00					14
	Slave	Instruction Header	Data Length	Device Type	Protocol Version	Return Instruction	Return Address	Data	Check Code
AA	08	42	01	D0	1C	XX	XX		

**Description:** Query the alarm exit level.  
The alarm exit level defaults to Level 1.  
**Example:** If the master sends D0 1C 00 14 and the slave returns AA 08 42 01 D0 1C 01 1E.  
This indicates that the alarm exit level is Level 1.  
**Note:** The valid values are 1~4, which correspond to Level L, level 2, Level 3 and Level 4.

Instruction R08	Master	Instruction	Address	Data					Check Code
		D0	1D	00					13
	Slave	Instruction Header	Data Length	Device Type	Protocol Version	Return Instruction	Return Address	Data	Check Code
AA	08	42	01	D0	1D	XX	XX		

**Description:** Query the warm-up time N×1s, default 180s.  
**Example:** If the master sends D0 1D 00 13 and the slave returns AA 08 42 01 D0 1D B4 6A.  
This indicates that the warm-up time is 0xB4 (180s).

Instruction R09	Master	Instruction	Address	Data					Check Code
		D0	00	00					30
	Slave	Instruction Header	Data Length	Device Type	Protocol Version	Return Instruction	Return Address	Data	Check Code
AA	08	42	01	D0	00	XX	XX		

**Description:** Query the calibration setting time, (N+8)×1s, default 60s.  
**Example:** If the master sends D0 00 00 30 and the slave returns AA 08 42 01 D0 00 34 07.  
This indicates that the calibration setting time is 0x34(52)+8=60s.

**Special Modification Instruction Description (W00~W05)**

Instruction W00	Master	Instruction	Address	Data					Check Code
		E0	1E	XX					XX
	Slave	Instruction Header	Data Length	Device Type	Protocol Version	Return Instruction	Return Address	Data	Check Code
AA		08	42	01	E0	1E	XX	XX	

**Description:** Modify the device serial interface data output enable control.  
 If the data is 0x08, this indicates that the serial interface output has been enabled and the serial interface will automatically output data once every period. If the data is 0x00, the serial interface will not output data.

**Example:** 1. If the master sends E0 1E 00 02 and the slave returns AA 08 42 01 E0 1E 00 0D.  
 This indicates that the current device serial interface is not enabled and the sensor does not have a serial data output.  
 2. If the master sends E0 1E 08 FA and the slave returns AA 08 42 01 E0 1E 08 05.  
 This indicates that the current device serial interface has been enabled and the serial interface will automatically output data once every period.

Instruction W01	Master	Instruction	Address	Data					Check Code
		E0	1F	XX					XX
	Slave	Instruction Header	Data Length	Device Type	Protocol Version	Return Instruction	Return Address	Data	Check Code
AA		08	42	01	E0	1F	XX	XX	

**Description:** Modify the device alarm output level.  
 If the data is 0x08, the STATUS port outputs high when alarming and low under normal conditions. 00H is the opposite.

**Example:** 1. If the master sends E0 1F 08 F9 and the slave returns AA 08 42 01 E0 1F 08 04.  
 This indicates that the STATUS port outputs high when alarming and low under normal conditions.  
 2. If the master sends E0 1F 00 01 and the slave returns AA 08 42 01 E0 1F 00 0C.  
 This indicates that the STATUS port outputs low when alarming and high under normal conditions.

Instruction W02	Master	Instruction	Address	Data					Check Code
		E0	1A	XX					XX
	Slave	Instruction Header	Data Length	Device Type	Protocol Version	Return Instruction	Return Address	Data	Check Code
AA		08	42	01	E0	1A	XX	XX	

**Description:** Modify the alarm level, which will take effect immediately.

**Example:** Modify the alarm level to Level 3.  
 If the master sends E0 1A 03 03 and the slave returns AA 08 42 01 E0 1A 03 0E.  
 This indicates that the alarm level was successfully changed to Level 3.

Note: The valid values are 1~4, which correspond to Level 1, Level 2, Level 3 and Level 4.

Instruction W03	Master	Instruction	Address	Data					Check Code
		E0	1C	XX					XX
	Slave	Instruction Header	Data Length	Device Type	Protocol Version	Return Instruction	Return Address	Data	Check Code
AA	08	42	01	E0	1C	XX	XX		

**Description:** Modify the alarm exit level, which will take effect immediately. The exit alarm value cannot be greater than or equal to the alarm value.  
**Example:** Modify the alarm exit level to Level 1.  
 If the master sends E0 1C 01 03 and the slave returns AA 08 42 01 E0 1C 01 0E.  
 This indicates that the alarm exit level was successfully changed to 1.  
**Note:** The valid values are 1~4, which correspond to Level 1, Level 2, Level 3 and Level 4.

Instruction W04	Master	Instruction	Address	Data					Check Code
		E0	1D	XX					XX
	Slave	Instruction Header	Data Length	Device Type	Protocol Version	Return Instruction	Return Address	Data	Check Code
AA	08	42	01	E0	1D	XX	XX		

**Description:** Modify the warm-up time,  $N \times 1s$ , which will take effect in the next warm-up.  
**Example:** If the master sends E0 1D B4 4F and the slave returns AA 08 42 01 E0 1D B4 5A,  
 This indicates that the warm-up time has been successfully modified to 0xB4 (180s).  
**Note:** The recommended modification range is  $30 \leq x < 255$ .

Instruction W05	Master	Instruction	Address	Data					Check Code
		E0	00	XX					XX
	Slave	Instruction Header	Data Length	Device Type	Protocol Version	Return Instruction	Return Address	Data	Check Code
AA	08	42	01	E0	00	XX	XX		

**Description:** Modify the calibration setting time,  $(N+8) \times 1s$ , which will take effect in the next calibration.  
**Example:** If the master sends E0 00 34 EC and the slave returns AA 08 42 01 E0 00 34 F7.  
 This indicates that the calibration setting time has been successfully modified to  $0x34(52)+8=60s$   
**Note:** The recommended modification range is  $30 \leq x < 240$ .

- Note: 1. In this document, all slave devices refer to the MEMS alcohol digital sensor, unless otherwise specified.
- The last byte of the 4-byte instruction sent by the master is the check code. Ensure the check code is correct otherwise the slave will consider the received data is incorrect and ignore it. Refer to the UART data format description section for the check code calculation method.
  - If any illegal instruction other than those aforementioned is used, the slave will return the original data sent by the master.
  - Data transmission and reception is in hexadecimal format unless otherwise specified.
  - When the sensor is in the warming-up or calibrating status, do not execute other instructions otherwise the sensor operating status will not be guaranteed.

## Considerations

### Usage Description

When storing the sensor for longer periods, a certain period of warm-up time is required after power on to achieve internal chemical equilibrium before use. If the sensor is stored for a long time after power off, the longer the aging time. If the alcohol module is powered off and stored for more than six months, it needs to be powered on and aged for more than three days before use. Care should be paid to heat dissipation during aging.

### Situations that Must Be Avoided

1. Exposure to volatile silicon compound gases

The sensor should avoid exposure to silicon adhesives, hair gels, silicone rubber, putty or other volatile silicon compounds. If the sensor surface absorbs volatile silicon compounds, the sensor sensitive material will be covered in silicon dioxide formed by the decomposition of silicon compounds. This will inhibit the sensor sensitivity and cannot be reversed.

2. Highly corrosive environment

If the sensor is exposed to high concentrations of corrosive gases (such as H<sub>2</sub>S, SO<sub>x</sub>, Cl<sub>2</sub>, HCl, etc.), it will not only cause corrosion or damage to heating materials and sensor leads but also cause irreversible deterioration of the sensitive material performance.

3. Pollution of alkali, alkali metal salts and halogens

If the sensor is contaminated with alkali metals, especially brine sprays or exposed to halogens such as Freon, it will also cause performance deterioration.

4. Contact with water

Being splashed or immersed in water can cause the sensor sensitivity to decrease.

5. Freezing

If water freezes on the sensor sensitive material surface, the sensitive layer will break and it will lose its sensitivity.

6. Apply power

Voltage overload may cause heating power to exceed 120mW, which can cause irreversible damage to the sensor. At the same time, the static electricity generated can also damage the sensor, so anti-static measures should be taken when contacting the sensor.

### Situations to be Avoided

1. Water Condensation

Indoor conditions, slight water condensation will influence the sensor's performance to a small extent. However, if water condenses on the sensor surface and is kept there for a certain period of time, the sensor's sensitivity will be decreased.

2. High gas concentrations

No matter whether the sensor is powered on or not, prolonged placement in high gas concentration situations will affect the sensor characteristics. If the sensor is sprayed directly with lighter gas, it will cause serious damage to the sensor.

3. Prolonged exposure to extreme environments

No matter whether the sensor is powered on or not, prolonged exposure to extreme environments, such as high humidity, high temperature or high pollution, will seriously affect the sensor performance.

4. Vibrations

Frequent and excessive vibrations, which may occur in transit or when using tools or ultrasonic welders on assembly line, may cause the internal sensor leads to resonate and break.

5. Impact

If the sensor is subjected to a strong impact or drop, its leads can break.

**Dimensions**

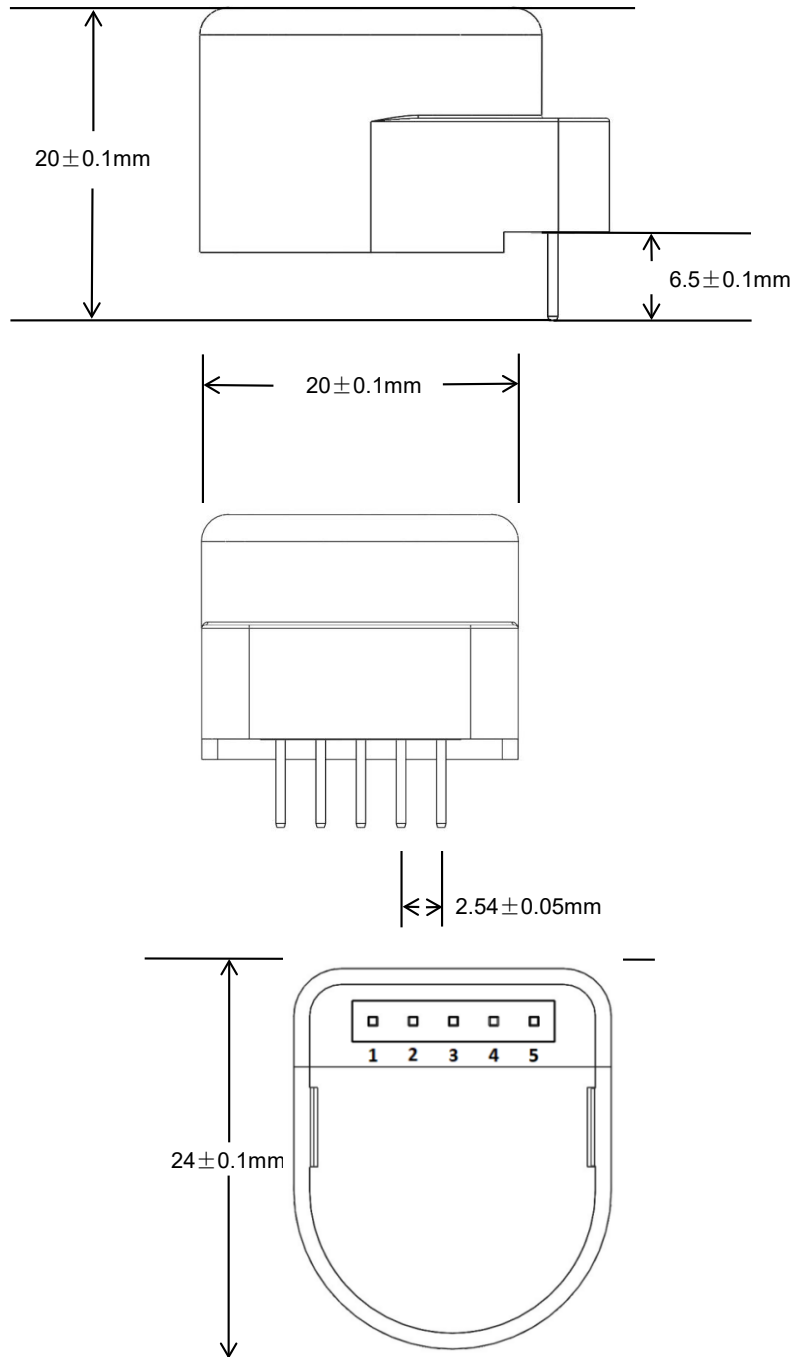

Copyright© 2023 by ANCHIP Electronic Technology Co. All Rights Reserved.

The information provided in this document has been produced with reasonable care and attention before publication, however, ANCHIP does not guarantee that the information is completely accurate. The information contained in this publication is provided for reference only and may be superseded by updates. ANCHIP disclaims any expressed, implied or statutory warranties, including but not limited to suitability for commercialization, satisfactory quality, specifications, characteristics, functions, fitness for a particular purpose, and non-infringement of any third-party's rights. ANCHIP disclaims all liability arising from the information and its application. In addition, ANCHIP does not recommend the use of ANCHIP's products where there is a risk of personal hazard due to malfunction or other reasons. ANCHIP hereby declares that it does not authorize the use of these products in life-saving, life-sustaining or safety critical components. Any use of ANCHIP's products in life-saving/sustaining or safety applications is entirely at the buyer's risk, and the buyer agrees to defend, indemnify and hold ANCHIP harmless from any damages, claims, suits, or expenses resulting from such use. The information provided in this document, including but not limited to the content, data, examples, materials, graphs, and trademarks, is the intellectual property of ANCHIP (and its licensors, where applicable) and is protected by copyright law and other intellectual property laws. No license, express or implied, to any intellectual property right, is granted by ANCHIP herein. ANCHIP reserves the right to revise the information described in the document at any time without prior notice. For the latest information, please contact us.