



---

**1D IR Gesture Control Digital Module**

**BM32S3021-1**

Revision: V1.00 Date: June 28, 2022

[www.holtek.com](http://www.holtek.com)

## Table of Contents

<b>Features</b> .....	<b>3</b>
<b>General Description</b> .....	<b>3</b>
<b>Applications</b> .....	<b>3</b>
<b>Selection Table</b> .....	<b>3</b>
<b>Pin Assignment</b> .....	<b>3</b>
<b>Pin Description</b> .....	<b>4</b>
<b>Schematic Diagram</b> .....	<b>4</b>
<b>Block Diagram</b> .....	<b>5</b>
<b>Absolute Maximum Ratings</b> .....	<b>5</b>
<b>D.C. Electrical Characteristics</b> .....	<b>5</b>
<b>A.C. Electrical Characteristics</b> .....	<b>6</b>
UART Interface.....	6
<b>Function Description</b> .....	<b>7</b>
System Description .....	7
<b>Application Circuits</b> .....	<b>8</b>
<b>Interface</b> .....	<b>8</b>
UART Interface.....	8
<b>Dimensions</b> .....	<b>11</b>

## Features

- 1D gesture recognition: Left/Right swipe, proximity sensing
- Operating voltage: 3.3V/5.0V
- Current consumption
  - ◆ Operating current: 3mA @ 3.3V
- Operating range
  - ◆ Z-axis distance: 5cm~25cm
  - ◆ X-axis distance: -7.5cm~+7.5cm
- Communication interface: UART

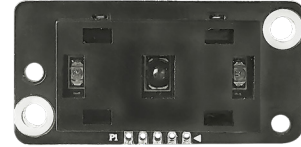

## General Description

The BM32S3021-1 is a 1D infrared gesture sensing module, which is designed for gesture detection applications. When hands enter the detection range, the reflected energy of the infrared will change. Gesture is determined by detecting changes in reflection between two infrared emitters. This module supports detection at a distance from 5cm to 25cm.

The module provides UART interface. When used together with a dedicated development platform, the required module characteristics can be rapidly adjusted. This modular design has an advantage of implement fast and convenient product development, which can be used to reduce product development period.

## Applications

- Lighting control
- Sound products
- Game controllers
- Automatic doors

## Selection Table

Part Number	Distance (25°C/Indoor)	Interface
BM32S3021-1	5cm~25cm	UART (9600bps)

## Pin Assignment

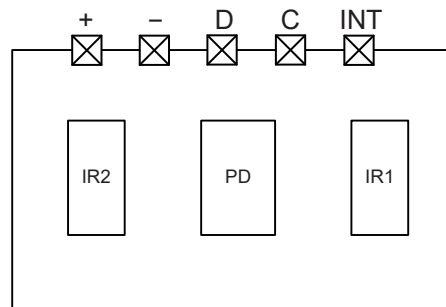

**Pin Description**

Pin Symbol	Type	Function	Description
INT	DO	Trigger	Gesture detection trigger pin
C	DI	RX	UART (9600bps) receiving pin
D	DO	TX	UART (9600bps) transmitting pin
-	PWR	GND	Connect to ground
+	PWR	VDD	Positive power supply ( $V_{DD} < 5.5V$ )

**Schematic Diagram**

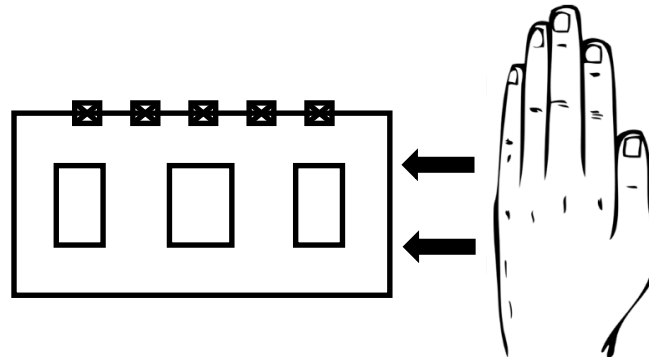

**Left Swipe**

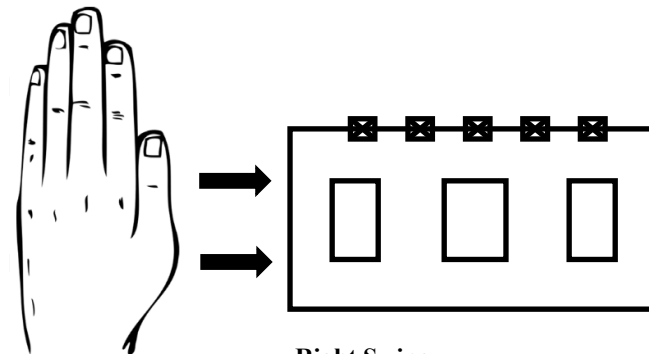

**Right Swipe**

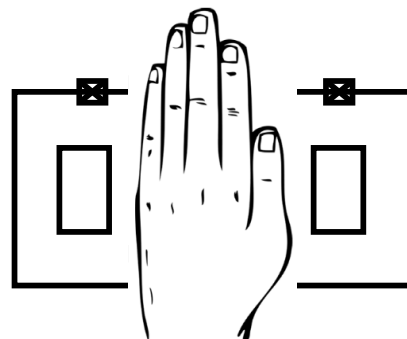

**Approaching**

## Block Diagram

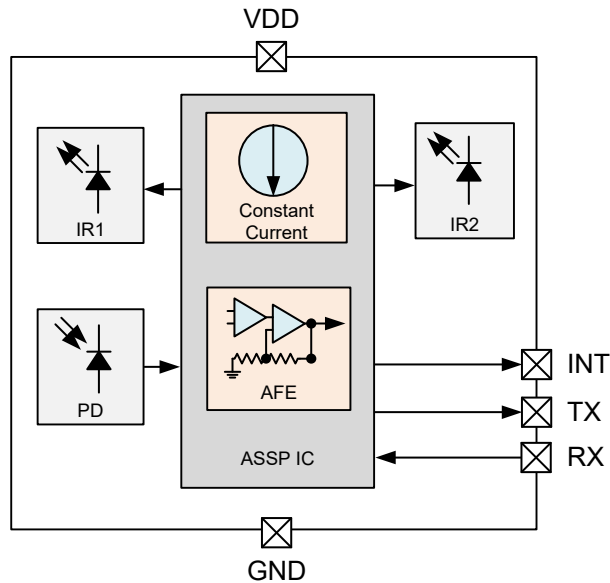

## Absolute Maximum Ratings

Supply Voltage .....	$V_{SS}-0.3V$ to $V_{SS}+5.5V$
Input Voltage .....	$V_{SS}-0.3V$ to $V_{DD}+0.5V$
Storage Temperature.....	$-40^{\circ}C$ to $85^{\circ}C$
Total Power Dissipation .....	500mW

Note: These are stress ratings only. Stresses exceeding the range specified under “Absolute Maximum Ratings” may cause substantial damage to the device. Functional operation of this device at other conditions beyond those listed in the specification is not implied and prolonged exposure to extreme conditions may affect device reliability.

## D.C. Electrical Characteristics

Symbol	Parameter	Test Conditions		Min.	Typ.	Max.	Unit
		$V_{DD}$	Conditions				
$V_{DD}$	Operating Voltage	—	—	3.0	—	5.5	V
$I_{DD}$	Operating Current (No Object Detected)	3.3V	—	—	3.00	4.00	mA
		5V		—	3.75	4.50	

## A.C. Electrical Characteristics

### UART Interface

Ta=25°C

Symbol	Parameter	Test Conditions		Min.	Typ.	Max.	Unit
		V <sub>DD</sub>	Conditions				
BDR	UART Baud Rate	—	—	—	9600	—	bps
t <sub>IDLE</sub>	Interval of each UART Data Transmission	—	—	10	—	—	ms

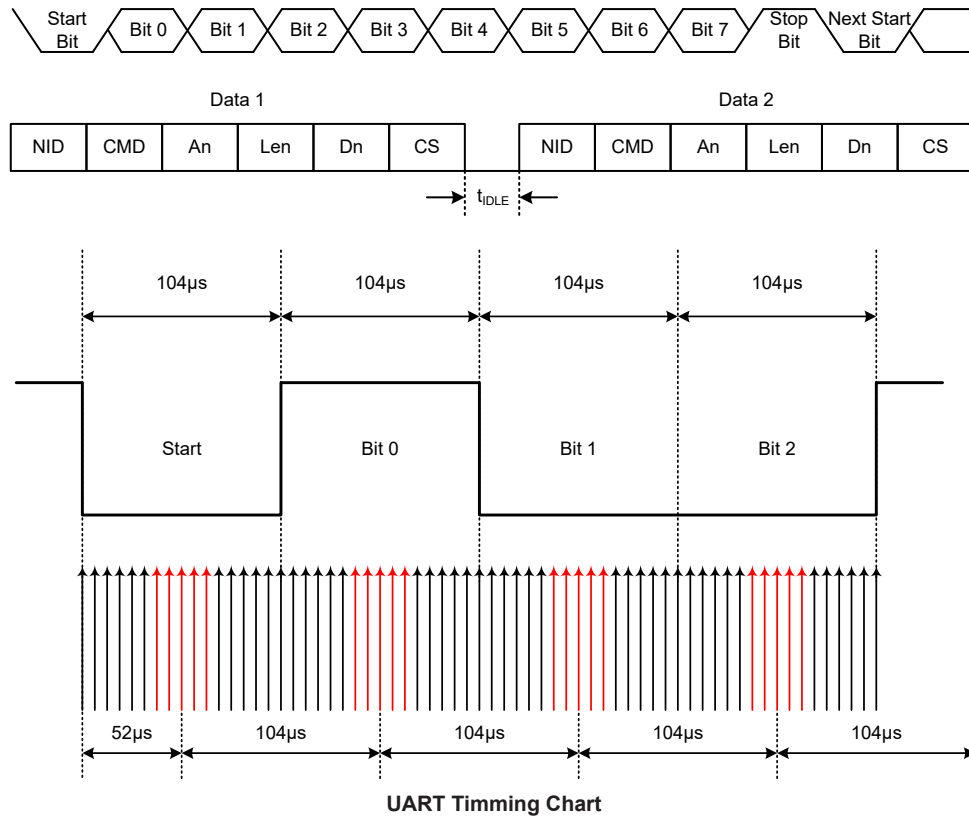

## Function Description

### System Description

This module can achieve stable gesture recognition action, help users quickly implement gesture function on products and reduce the product development period.

### Operating Principle

The BM32S3021-1 executes initialization after system power on, then it starts detection cycle by cycle. When there is a gesture change, the INT pin level will output low active. The device can get the gesture direction and proximity status through the UART interface.

### Reading Gesture Method

The host device can read the value from the BM32S3021-1 via the corresponding UART command. Continuous reading is allowed.

When the module transmits the data back to the host device, or the INT pin output occurs time-out, the module will automatically clear the gesture status. Note that this module will not automatically clear the proximity status.

Communication Method	Minimum Continuous Reading Interval Time	Unit
UART	10	ms

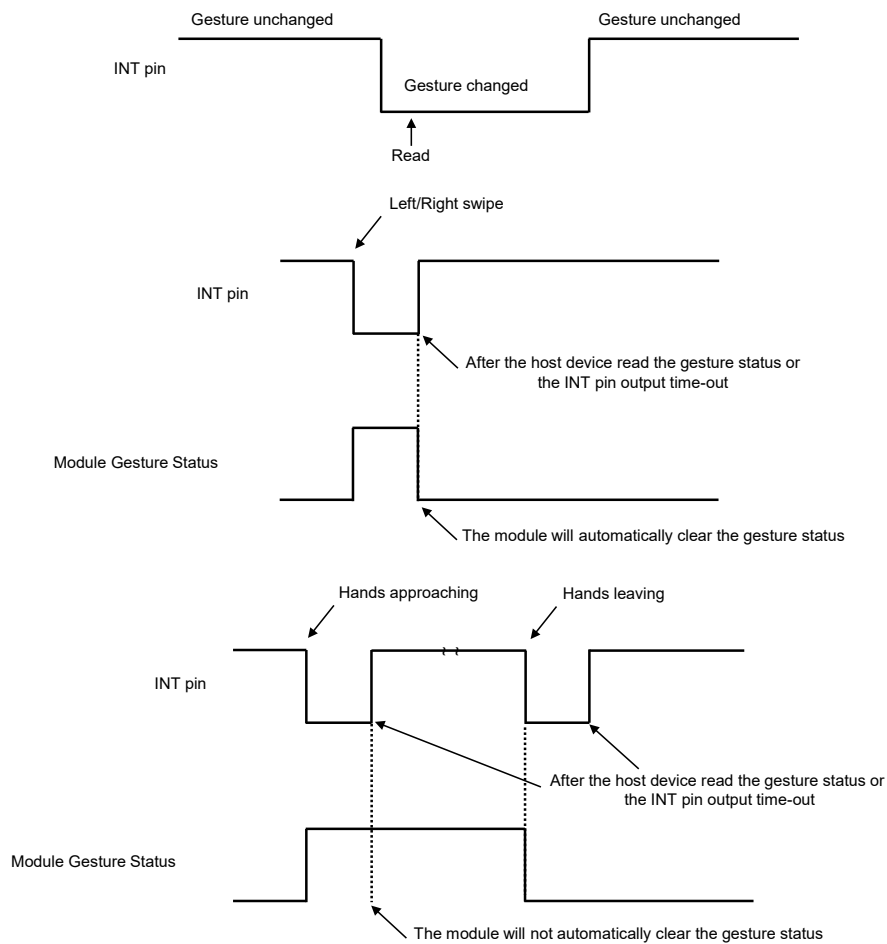

**Gesture Timing Chart**

## Application Circuits

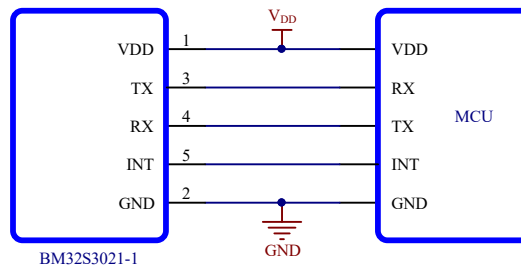

## Interface

The BM32S3021-1 supports the UART communication method. In the UART mode, the host device can read the measurement result and device information from the BM32S3021-1. More details about the communication are described in the following UART section.

### UART Interface

The UART protocol is as follows:

1. Preamble ID(PID): 0x55
2. Command (CMD):
  - 0x80: read parameters from module.
  - 0xC0: write parameters to module.
3. Register address: An
4. Data length: Len
5. Data: Dn
6. CheckSum (CS): CS=PID+CMD+An+LEN+Dn; (take the lower 8 bits of the checksum)

PID	Command	Register Address	Data length	Data	CheckSum
0x55	CMD	An	Len	Dn	CS
1	2	3	4	5	6

### Special Commands

No.	PID	CMD	CS	Content
1	0x55	0x10	0x65	Module Reset. Module Response: 0x55, Ack, CS.
2	0x55	0x19	0x6E	Module Enters Distance Learning Mode. Place the object to be detected at the desired distance. After the instruction is executed, the module INT pin level is pulled low, when the distance learning is completed, the INT pin level will be set high. Module Response: 0x55, Ack, CS.

**Read Commands**

No.	PID	CMD	An	Len	CS	Content
1	0x55	0x80	0x00	0x01	0xD6	Version Information Low Byte. Dn: Version low byte. Module Response: 0x55, 0xC0, 0x00, 0x01, Dn, CS.
2	0x55	0x80	0x01	0x01	0xD7	Version Information High Byte. Dn: Version high byte. Module Response: 0x55, 0xC0, 0x01, 0x01, Dn, CS.
3	0x55	0x80	0x02	0x01	0xD8	Gesture Sensing Status. Dn: Bit 3: Calibration status 0: General mode 1: Calibration is in progress Bit 2: Left swipe status 0: Left swipe has finished 1: Left swipe has setup Bit 1: Right swipe status 0: Right swipe has finished 1: Right swipe has setup Bit 0: Proximity Sensing Status 0: No object approaching 1: There is an object approaching Module status: 0x55, 0xC0, 0x02, 0x01, Dn, CS.
4	0x55	0x80	0x03	0x01	0xD9	The left/right swipe times. Dn: Cumulative times. (-127~128) -n = left swipe times, n = right swipe times Module Response: 0x55, 0xC0, 0x03, 0x01, Dn, CS.
5	0x55	0x80	0x04	0x01	0xDA	IR1 Reference Value. Dn: IR1 reference value. Module Response: 0x55, 0xC0, 0x04, 0x01, Dn, CS.
6	0x55	0x80	0x05	0x01	0xDB	IR2 Reference Value. Dn: IR2 reference value. Module Response: 0x55, 0xC0, 0x05, 0x01, Dn, CS.
7	0x55	0x80	0x06	0x01	0xDC	Gesture Trigger Debounce Times (Noise Filter). Dn: 0~255 (default 7). Module Response: 0x55, 0xC0, 0x06, 0x01, Dn, CS.
8	0x55	0x80	0x07	0x01	0xDD	Gesture Trigger Threshold Value. Dn: 10~200. Module Response: 0x55, 0xC0, 0x07, 0x01, Dn, CS.
9	0x55	0x80	0x08	0x01	0xDE	The IRQ trigger time when the gesture has setup. Dn: 0~255 (default 50). IRQ trigger time is calculated as below: Dn×4ms, (default 50×4ms=200ms) Module Response: 0x55, 0xC0, 0x08, 0x01, Dn, CS.
10	0x55	0x80	0x09	0x01	0xDF	Cumulative continuous swipe time. Dn: 0~127 (default 30). IRQ trigger time is calculated as below: Dn×64ms, (default 30×64ms=1.92s) Module Response: 0x55, 0xC0, 0x09, 0x01, Dn, CS.
11	0x55	0x80	0x0A	0x01	0xE0	The fastest gesture detected time. Dn: 0~200 (default 0). IRQ trigger time is calculated as below: 20+Dn×4ms, (default 20+0×4ms=20ms) Module Response: 0x55, 0xC0, 0x0A, 0x01, Dn, CS.
12	0x55	0x80	0x0B	0x01	0xE1	The slowest gesture detected time. Dn: 0~200 (default 80). IRQ trigger time is calculated as below: Dn×64ms, (default 80×16ms=1.28s) Module Response: 0x55, 0xC0, 0x0B, 0x01, Dn, CS.

**Continuous Read Commands**

No.	PID	CMD	An	Len	CS	Content
1	0x55	0x80	0x02	0x04	0xDB	Reading the gesture sensing status, left/right swipe times, IR1 reference value and IR2 reference value at once. D1: Gesture sensing status. D2: Left/right swipe times. D3: IR1 reference value. D4: IR2 reference value. Module Response: 0x55, 0xC0, 0x02, 0x04, D1~D4, CS.

**Write Commands**

No.	PID	CMD	An	Len	Dn	CS	Content
1	0x55	0xC0	0x06	0x01	Dn	CS	Gesture Trigger Debounce Times (Noise Filter). Dn: 0~255 (default 7). Module Response: 0x55, Ack, CS.
2	0x55	0xC0	0x07	0x01	Dn	CS	Gesture Trigger Threshold Value. Dn: 10~200. Module Response: 0x55, Ack, CS.
3	0x55	0xC0	0x08	0x01	Dn	CS	The IRQ trigger time when the gesture has setup. Dn: 0~255 (default 50). IRQ trigger time is calculated as below: Dn×4ms, (default 50×4ms=200ms) Module Response: 0x55, Ack, CS.
4	0x55	0xC0	0x09	0x01	Dn	CS	Cumulative continuous swiping time. Dn: 0~255 (default 30). IRQ trigger time is calculated as below: Dn×64ms, (default 30×64ms=1.92s) Module Response: 0x55, Ack, CS.
5	0x55	0xC0	0x0A	0x01	Dn	CS	The fastest gesture detected time. Dn: 0~200 (default 0). IRQ trigger time is calculated as below: 20+Dn×4ms, (default 20+0×4ms=20ms) Module Response: 0x55, Ack, CS.
6	0x55	0xC0	0x0B	0x01	Dn	CS	The slowest gesture detected time. Dn: 0~200 (default 80). IRQ trigger time is calculated as below: Dn×64ms, (default 80×16ms=1.28s) Module Response: 0x55, Ack, CS.

**Module Responses**

No.	PID	Ack	CS	Content
1	0x55	0x7F	D4	Completed
2	0x55	0x7E	D3	Failed

**Dimensions**

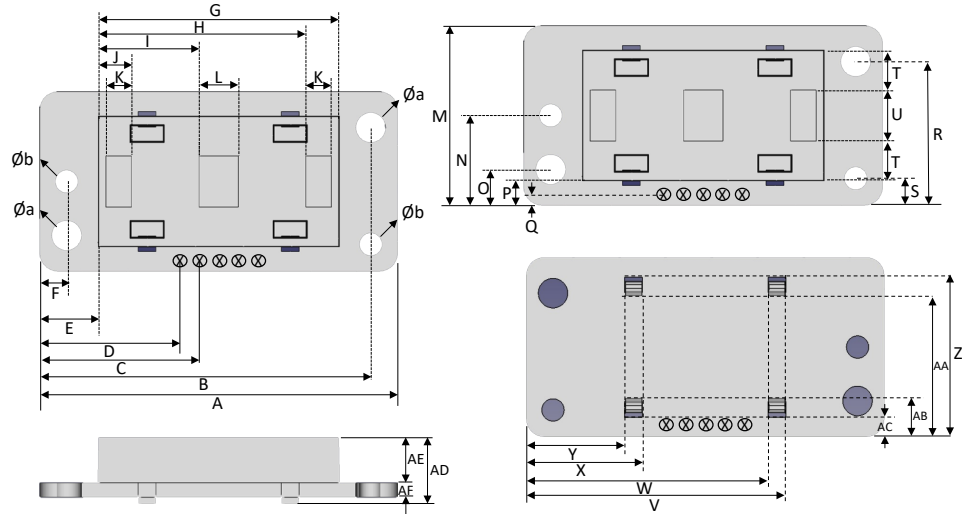

No.	Unit	
	mm	inch
Øa	3.3	0.13
Øb	2.5	0.098
A	40	1.575
B	37	1.457
C	18	0.709
D	16	0.63
E	6.5	0.256
F	3	0.118
G	27	1.063
H	23.35	0.919
I	11.3	0.445
J	3.65	0.144
K	2.85	0.112
L	4.4	0.173
M	20	0.787
N	10	0.394
O	4	0.157
P	2.8	0.11
Q	1.3	0.051
R	16	0.63
S	3	0.118
T	4.4	0.173
U	5.6	0.22
V	29	1.142
W	27	1.063
X	13	0.512
Y	11	0.433
Z	17.8	0.701
AA	15.8	0.622

No.	Unit	
	mm	inch
AB	4.2	0.165
AC	2.2	0.087
AD	7.6	0.299
AE	5	0.197
AF	1.6	0.063

Copyright© 2022 by HOLTEK SEMICONDUCTOR INC.

The information provided in this document has been produced with reasonable care and attention before publication, however, Holtek does not guarantee that the information is completely accurate and that the applications provided in this document are for reference only. Holtek does not guarantee that these explanations are appropriate, nor does it recommend the use of Holtek's products where there is a risk of personal hazard due to malfunction or other reasons. Holtek hereby declares that it does not authorise the use of these products in life-saving, life-sustaining or critical equipment. Holtek accepts no liability for any damages encountered by customers or third parties due to information errors or omissions contained in this document or damages encountered by the use of the product or the datasheet. Holtek reserves the right to revise the products or specifications described in the document without prior notice. For the latest information, please contact us.