



0.96" OLED Display Module

BMD31M090 User Guide

Revision: V1.00 Date: April 17, 2023

www.bestmodulescorp.com

Contents

Introduction	3
Features	3
Block Diagram	4
Pin Description	4
Technical Specification	4
Recommended Operating Conditions	4
Timing Specification	5
Hardware Overview	5
Power Supply	6
Communication Interface	6
Jumper	6
Application Circuits	7
Dimensions	7

Introduction

The BMD31M090 is a 0.96" OLED display module from Best Modules, which is developed by using an OLED driver the IC, SSD1306. The OLED display technology has the characteristic of self-illumination to display content on the screen. The screen resolution is 128×64, with white-on-black. The module has large angle of visibility and low power consumption. The module can use the BMCOM interface, which can display string, drawing, marking, picture scrolling and other functions through the I²C communication mode. The module is suitable for various display products.

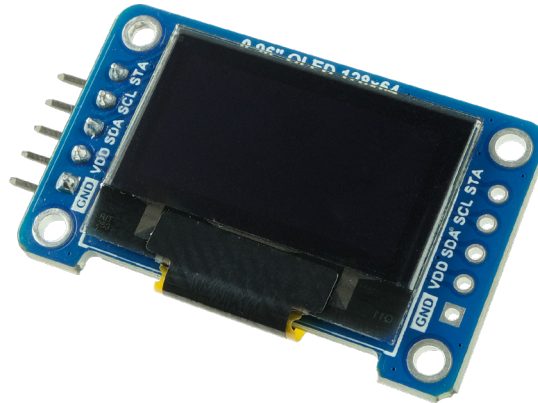

Features

- Operating voltage: 3.3V~5.5V
- Working current: 30mA @ 5V
- Standby current: <10μA @ 5V
- Driver IC: SSD1306
- Characteristics of module:
 - ◆ Resolution: 128×64
 - ◆ Black-on-white or white-on-black
 - ◆ Large angle of visibility
 - ◆ Low power consumption
- Communication interface:
 - ◆ BMCOM×1 (STA, SCL, SDA, VDD, GND)
 - ◆ Communication mode: I²C (Address: Default 0x3C)
- Provides Arduino Library support
- Module size: 37.34mm×23.30mm×7.78mm

Block Diagram

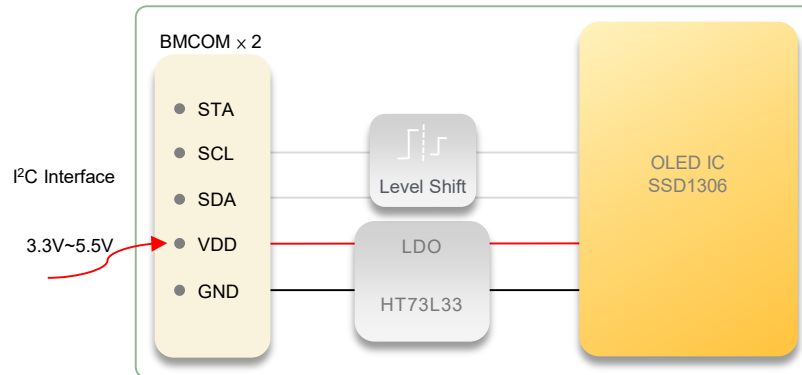

Pin Description

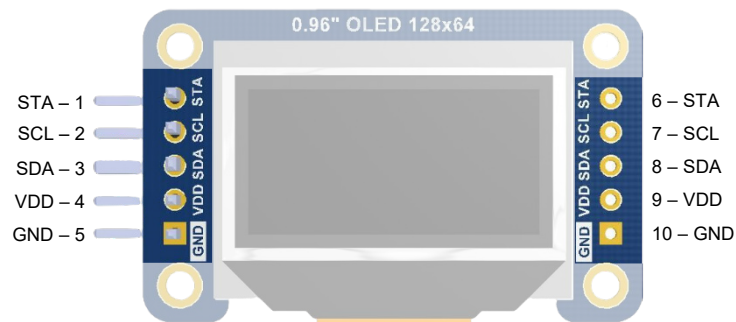

Pin	Function	Description
1&6	STA	STA pins on both sides of the module are internally connected Note: Not used in this module
2&7	SCL	I ² C clock line
3&8	SDA	I ² C data line
4&9	VDD	Positive power supply
5&10	GND	Negative power supply, ground

Technical Specification

Recommended Operating Conditions

T_a=25°C

Symbol	Parameter	Condition	Min.	Typ.	Max.	Unit
V _{DD}	Operating Voltage	—	3.3	—	5	V
I _{DD}	Working Current	V _{DD} =5V Full light display	—	30	—	mA
I _{STB}	Standby Current	V _{DD} =5V	—	10	—	μA

Timing Specification

Ta=25°C

Symbol	Parameter	Condition	Min.	Typ.	Max.	Unit
t _{DEL-RSP}	Response Delay Time	V _{DD} =5V	—	5	—	ms
t _{INR}	Interval Time	V _{DD} =5V	10	—	—	ms

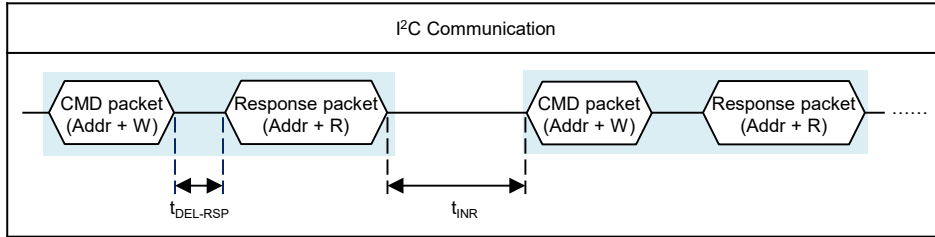

Hardware Overview

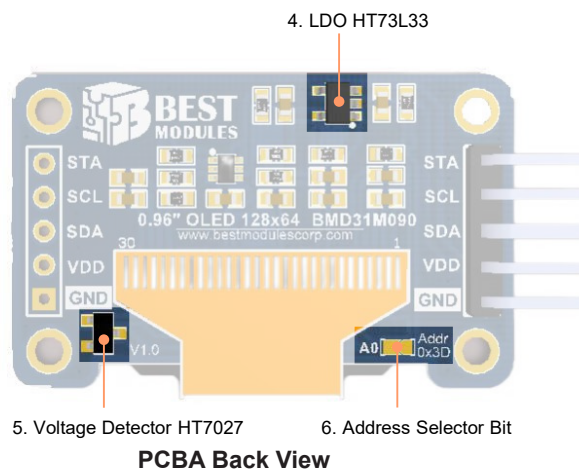
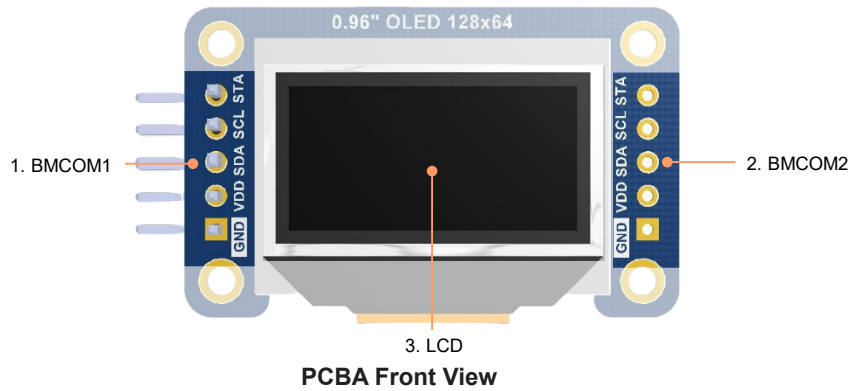

Power Supply

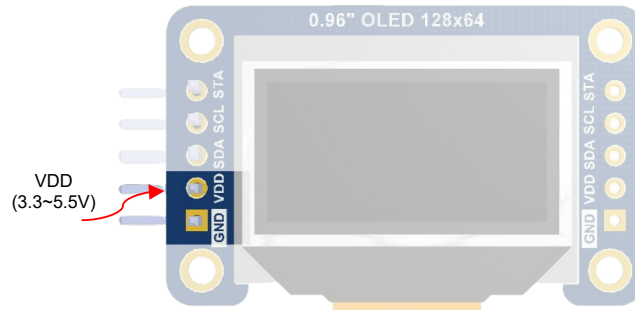

- BCOM Pin: Enter 3.3V to 5.5V through VDD

Communication Interface

- Communication mode: I²C
 - I²C Address: Default 0x3C
- I²C Address Format:

MSB							LSB
A6	A5	A4	A3	A2	A1	A0	R/W
0	1	1	1	1	0	0	

Slave address (0x3C)

Note: R/W=1: Read direction
=0: Write direction

- I²C Communication rate: $\leq 400\text{kHz}$
- Communication logic reference voltage: 2.5V~5.5V
- The SCL/SDA pin of module with 10k Ω pull-up resistor
- Communication protocol:
 - ◆ Refer to the SSD1306 datasheet

Jumper

- I²C Address selection:

A0-0x3D	I ² C Address
Open circuit	0x3C (Factory default)
Short circuit	0x3D

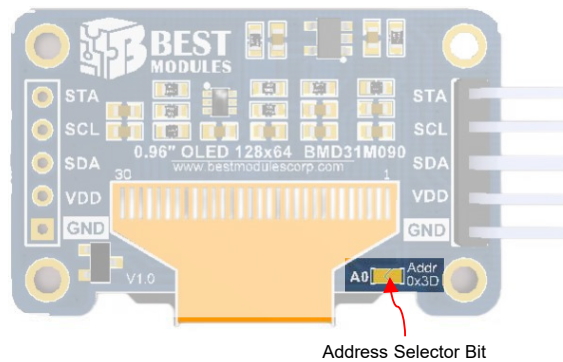

Application Circuits

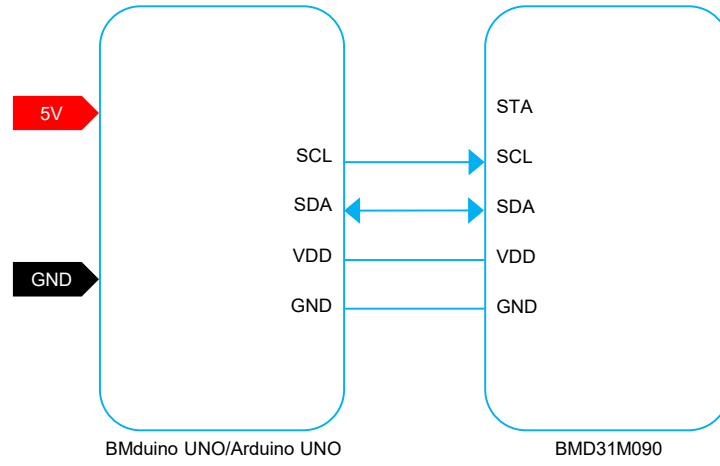

Connection Diagram

Dimensions

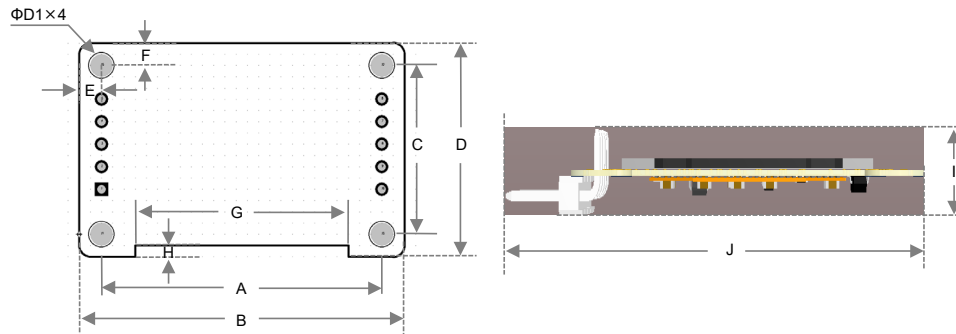

Dimension Information

No.	Unit	mm	inch
A		32.04	1.261
B		37.34	1.470
C		18.00	0.709
D		23.30	0.917
E		2.63	0.104
F		2.69	0.106
G		24.92	0.981
H		1.90	0.075
I		7.78	0.306
J		41.34	1.628
ΦD1		2.2	0.087

Dimension List

Copyright© 2023 by BEST MODULES CORP. All Rights Reserved.

The information provided in this document has been produced with reasonable care and attention before publication, however, BEST MODULES does not guarantee that the information is completely accurate. The information contained in this publication is provided for reference only and may be superseded by updates. BEST MODULES disclaims any expressed, implied or statutory warranties, including but not limited to suitability for commercialization, satisfactory quality, specifications, characteristics, functions, fitness for a particular purpose, and non-infringement of any third-party's rights. BEST MODULES disclaims all liability arising from the information and its application. In addition, BEST MODULES does not recommend the use of BEST MODULES' products where there is a risk of personal hazard due to malfunction or other reasons. BEST MODULES hereby declares that it does not authorize the use of these products in life-saving, life-sustaining or safety critical components. Any use of BEST MODULES' products in life-saving/sustaining or safety applications is entirely at the buyer's risk, and the buyer agrees to defend, indemnify and hold BEST MODULES harmless from any damages, claims, suits, or expenses resulting from such use. The information provided in this document, including but not limited to the content, data, examples, materials, graphs, and trademarks, is the intellectual property of BEST MODULES (and its licensors, where applicable) and is protected by copyright law and other intellectual property laws. No license, express or implied, to any intellectual property right, is granted by BEST MODULES herein. BEST MODULES reserves the right to revise the information described in the document at any time without prior notice. For the latest information, please contact us.