

BC2161 Parameter Setting Tool

D/N: AN0526EN

Overview

The BCE-EFUSEK8-001 is a specially designed quick-start development board by Bestcomm for the BC2161 wireless transmitting module.

Functional Description

The development board can select user desired RF parameters using the PC's software, download the selected RF parameters to the development board, store them in EEPROM and then write to the BC2161 registers. Its operating mode is an I²C emulated KEY mode. This method can avoid the problem whereby users are unable to change parameters repeatedly after the BC2161 EFUSE is programmed when the BC2161 is in the KEY Mode.

Operating Principle

The following diagram shows the system architecture of the development board. The development board communicates with external devices through the USB/UART interface and communicates with the BC2161 module through GPIOs (I²C) and Keys. Users just need to configure the parameters and press the keys to send signals, without being concerned whether the programmed EFUSE can be reused.

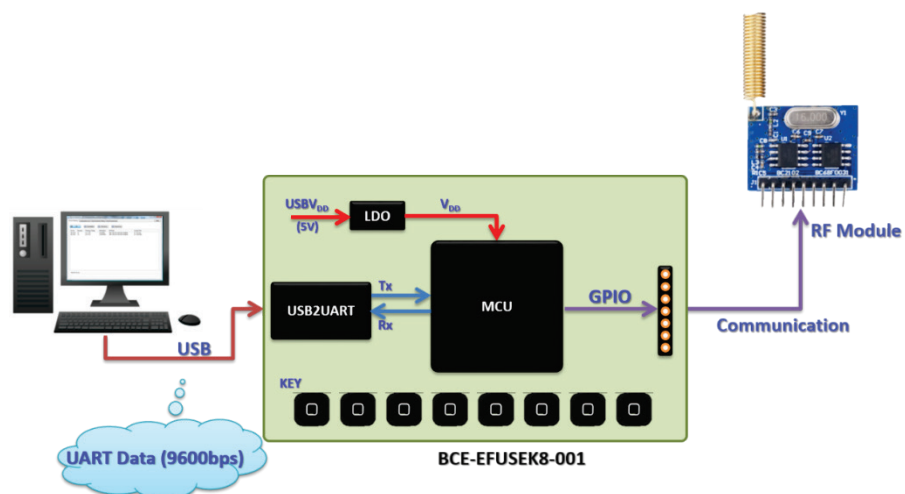

Hardware Description

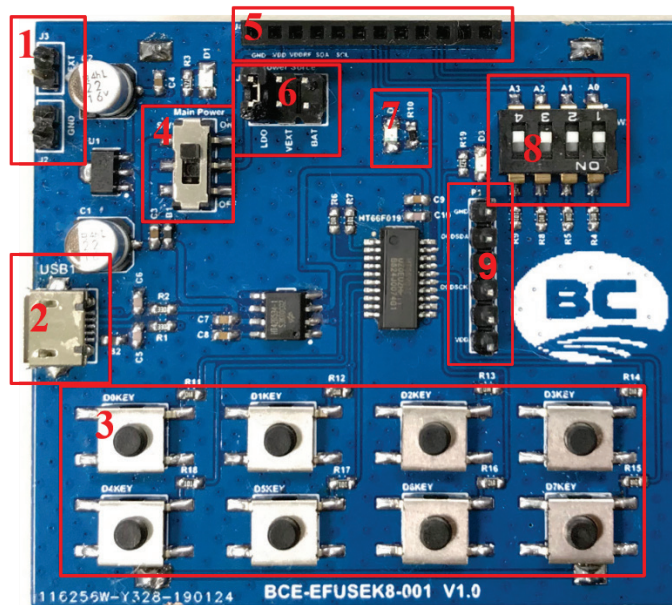

1. External power input port: Users can directly provide power supply for the whole system through this pin. If external power is required, the VEXT pin should be selected as the power source.
2. USB interface: A PC port can send commands and data to the system through this connector. This interface can also provide a 3.3V power supply for the system. If external power is required, the LDO pin should be selected as the power source.
3. 8 keys: Users can select the data to be transmitted using these keys. The high and low bit order of the data must be matched with the LSB/MSB setting, which allows multiple keys.
4. Main power switch: This is the power supply switch for the system.
5. BC2161 module interface: Connect a BC2161 module to this pin to operate.
6. Power source selection: The BCE-EFUSEK8-001 development board has three power sources. These are external power (connected to the external power input port), USB (connected to the USB interface) and batteries (two AA batteries can be installed in the back of the development board).
7. Transmission indicator: After the BC2161 module transmits data successfully, this indicator will turn on and then immediately turn off. This allows the BC2161 module transmission status to be easily detected.
8. BC2161 address selection: The BC2161 can use 4 keys to select the address mode (only available for the 16-pin package). After users select this mode, the transmitted address can be set using the DIP switches.
9. OCDS interface: This interface can be connected to e-Link for emulation or to e-WriterPro for program programming.

Program Programming

1. Save the solution attachment to PC.
2. Connect the corresponding e-WriterPro interface to the OCDS interface on the development board.

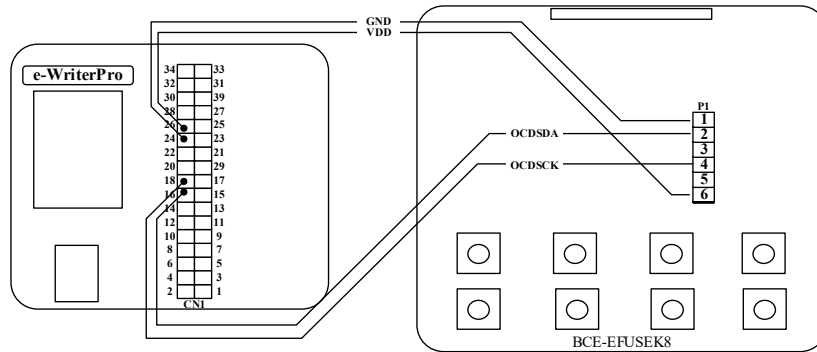

3. Click on the HOPE3000.

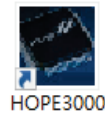

4. Select “File” in the menu bar and then click “Open and Download”.

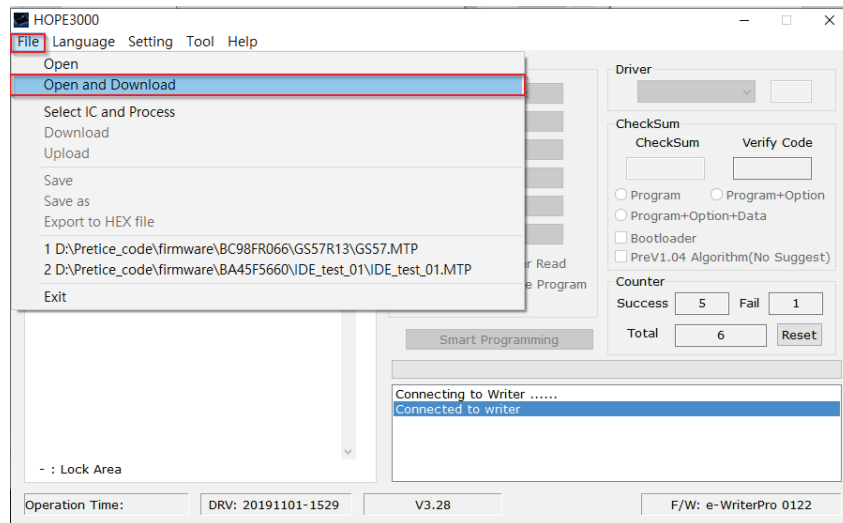

5. Open the “EFUSEK8-BC2161.MTP” file.

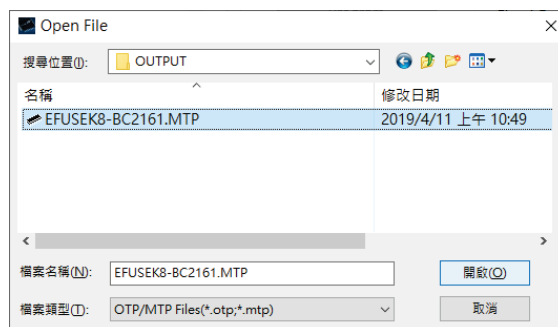

- Select "ICP(e-CON12C) 3V" as the IC package.

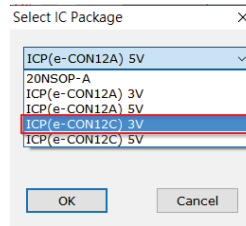

- The programming can be implemented by clicking the buttons "Blank Check", "Program", "Verify" and "Lock" as shown in the red box below.

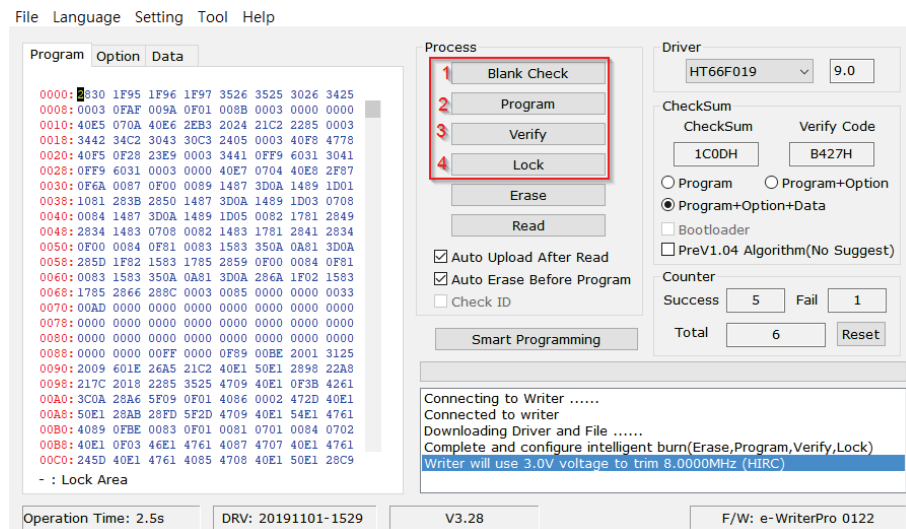

- When a "Complete and ok" message appears, it indicates that the program has been programmed successfully. Then the next step can be executed.

Operation Description

- Insert the BC2161 module into the development board, power on and connect to the USB interface.

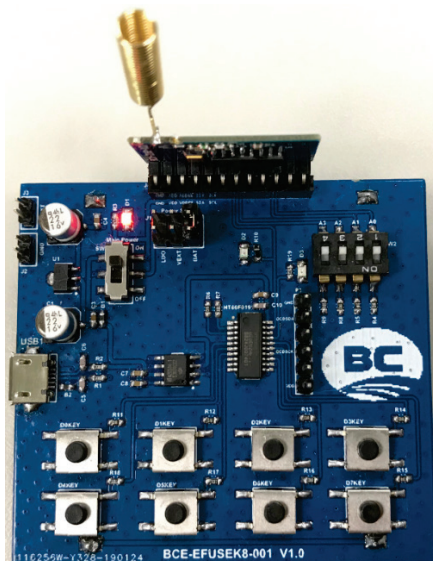

2. Implement the “RF chip parameter setting tool” program. Note: The emulation function is not supported until version 1.61.

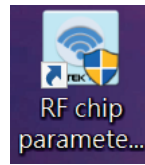

3. In the “Device Selection” TAB, double-click on “BC2161”.

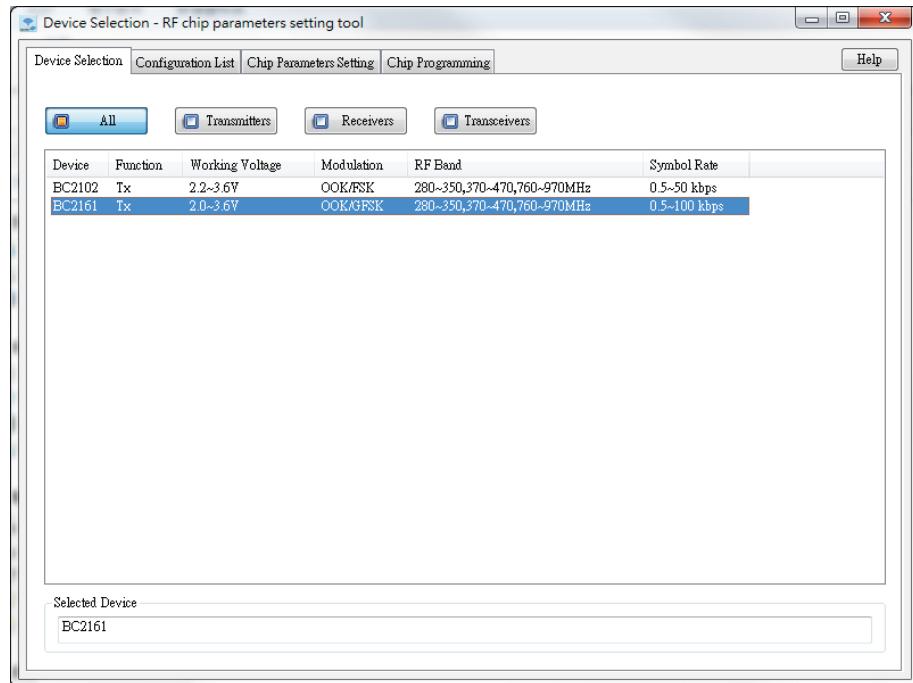

4. In the “Configuration List” TAB, select new file or old files.

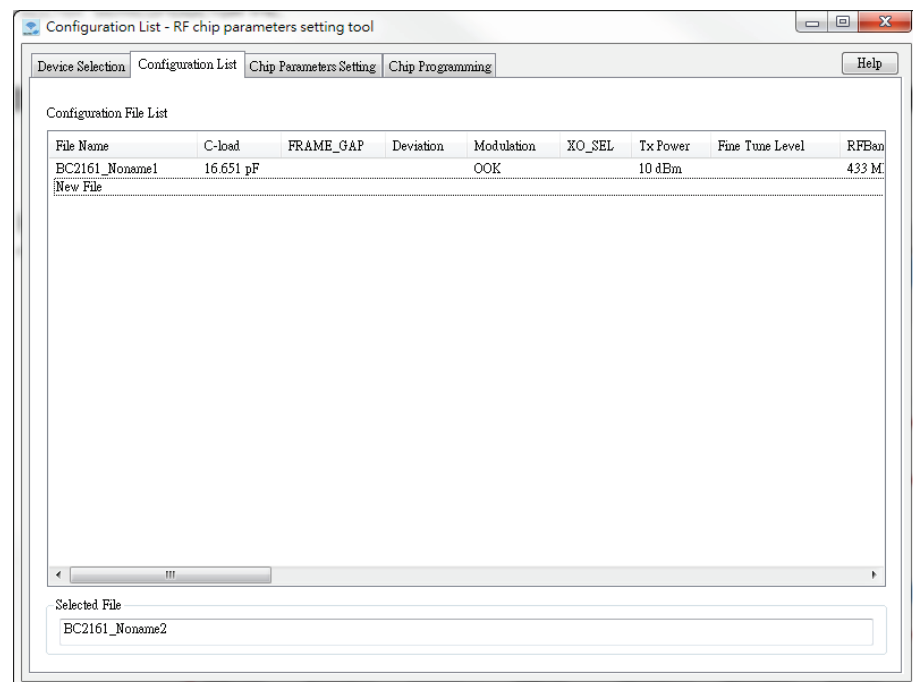

5. In the “Chip Parameters Setting” TAB, select the required parameters.

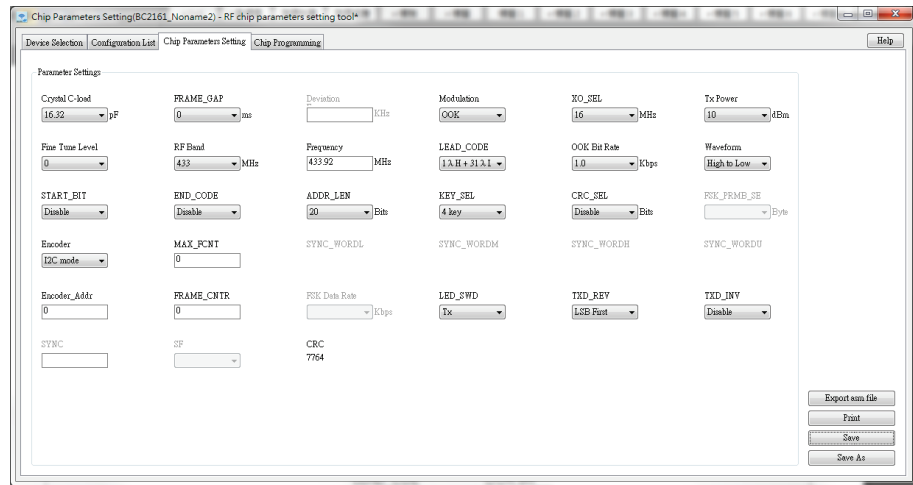

Note that the development board uses the BC2161 module I²C mode to emulate the KEY mode through the application program and also uses an LED_SWID return signal to indicate a successful transmission. This means that the current Encoder and LED_SWID parameters in the platform are restricted, these parameters will be forced to the “I²C Mode” and “Tx” after being adjusted into the platform program by the software. Therefore, this platform is designed to provide easy adjustment of the RF parameters. If these two parameters are required be used, the user must program them into the BC2161 module.

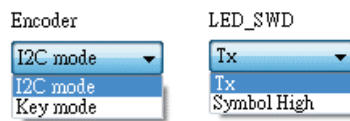

If users want to use the hardware address function, as the transmission function for both address and data is not supported in the I²C mode, the KEY mode should be selected by programming the corresponding BC2161 FUSE according to proper parameter settings.

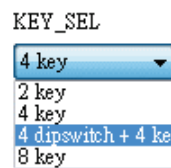

6. In the “Chip Programming” TAB, implement the following steps.

Step 1. Click on “Emulated”.

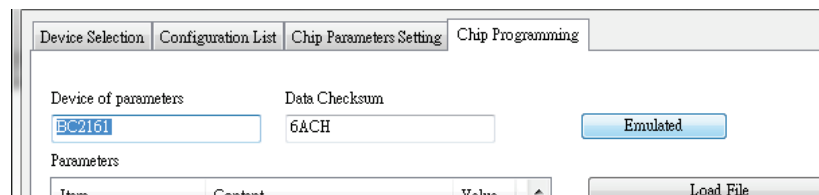

Step 2. Select the COM number corresponding to the USB.

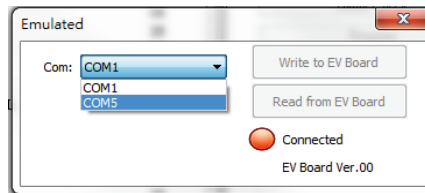

Step 3. Click on “Write to EV Board” to download the current setting values to the development board to provide the BC2161 module parameters. Click on “Read from EV Board” to read the current BC2161 module parameters to the PC and display them.

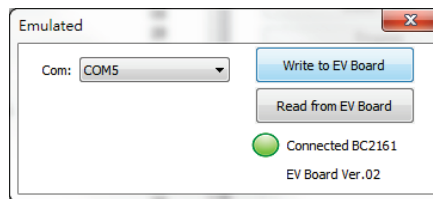

7. When a “Write to EV Board Success” message appears to indicate that a data download has completed, the keys can be directly pressed to make the BC2161 module development board send data.

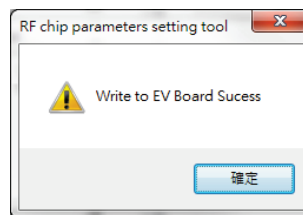

When a “Read from EV Board Success” message appears to indicate that a data upload has completed, the current BC2161 module parameters can be checked in the parameter list on the left of the current page.

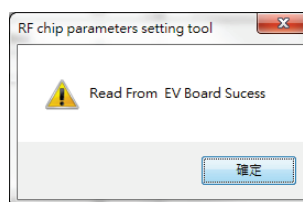

Conclusion

Using the “BCE-EFUSEK8” together with the “RF chip parameter setting tool”, users can easily implement the RF encoder chip BC2161 configurations.

References

Reference document: BC2161 Datasheet.

For more information, refer to the Holtek official website: <https://www.holtek.com>.

Version and Modify Information

Version Information

Date	Author	Issue and Revision
2020.06.05	何信智	V1.10
2019.03.29	Popo Wu (吴柏颖)	V1.00

Modify Information

V1.10: A new “Program Programming” section and a programming program attachment have been added.

Disclaimer

All information, trademarks, logos, graphics, videos, audio clips, links and other items appearing on this website ('Information') are for reference only and is subject to change at any time without prior notice and at the discretion of Holtek Semiconductor Inc. and its related companies (hereinafter 'Holtek', 'the company', 'us', 'we' or 'our'). Whilst Holtek endeavors to ensure the accuracy of the Information on this website, no express or implied warranty is given by Holtek to the accuracy of the Information. Holtek will bear no responsibility for any incorrectness or leakage.

Holtek will not be liable for any damages (including but not limited to computer virus, system problems or data loss) whatsoever arising in using or in connection with the use of this website by any party. There may be links in this area, which allow you to visit the websites of other companies. These websites are not controlled by Holtek. Holtek will bear no responsibility and no guarantee to whatsoever Information displayed at such sites. Hyperlinks to other websites are at your own risk.

Limitation of Liability

In any case, the Company has no need to take responsibility for any loss or damage caused when anyone visits the website directly or indirectly and uses the contents, information or service on the website.

Governing Law

This disclaimer is subjected to the laws of the Republic of China and under the jurisdiction of the Court of the Republic of China.

Update of Disclaimer

Holtek reserves the right to update the Disclaimer at any time with or without prior notice, all changes are effective immediately upon posting to the website.