



24-Bit ADC Module

BMH23M001 User Guide

Revision: V1.00 Date: April 19, 2023

www.bestmodulescorp.com

Contents

Introduction	3
Features	3
Block Diagram	4
Pin Description	5
Technical Specification	6
Recommended Operating Conditions	6
Timing Specification	6
Hardware Overview	7
Power Supply	7
Analog Signal Input Interface Selection	8
Communication Interface	8
Jumper	9
Application Circuits	9
Dimensions	10

Introduction

The Best Modules BMH23M001 is a 24-bit ADC module, which is developed by using 24-bit ADC IC, the BH45B1225. The module principle is based on ADC analog-to-digital conversion. The module has two ADC input interfaces, which can be used with sensors based on Wheatstone bridge principle. The on-board LDO has the characteristics of low output noise, which makes the ADC measurement accuracy more accurate and stable. The module can be used together with a Level Shift circuit, the module supports wide voltage of 3.3V~5.5V. The module can use I²C communication mode through BMCOM interface to read AD value and other functions. The module is suitable for use in smart products such as smart cups and coffee machines.

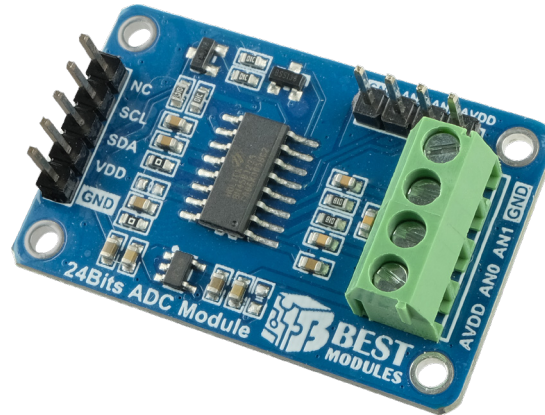

Features

- Operating voltage: 3.3~5.5V
- Operating current: 1mA @ 5V
- Standby current: <1.5 μ A @ 5V (No load)
- 24-bit ADC IC: BH45B1225
- 24-bit resolution A/D converter, the average Effective Number of Bits (ENOB) is up to 21.9 bits
- Analog signal input interfaces:
 - ◆ Wheatstone bridge sensor interface \times 1 – AVDD, AN0, AN1, GND
 - ◆ Analog signal input interface \times 1 – AVDD, AN2, AN3, GND
- Communication interface:
 - ◆ BMCOM \times 1 – NC, SCL, SDA, VDD, GND
 - ◆ Communication mode: I²C (address: default 0x68)
- Provides Arduino Library support
- Module size: 39.0mm \times 24.6mm \times 12.2mm

Block Diagram

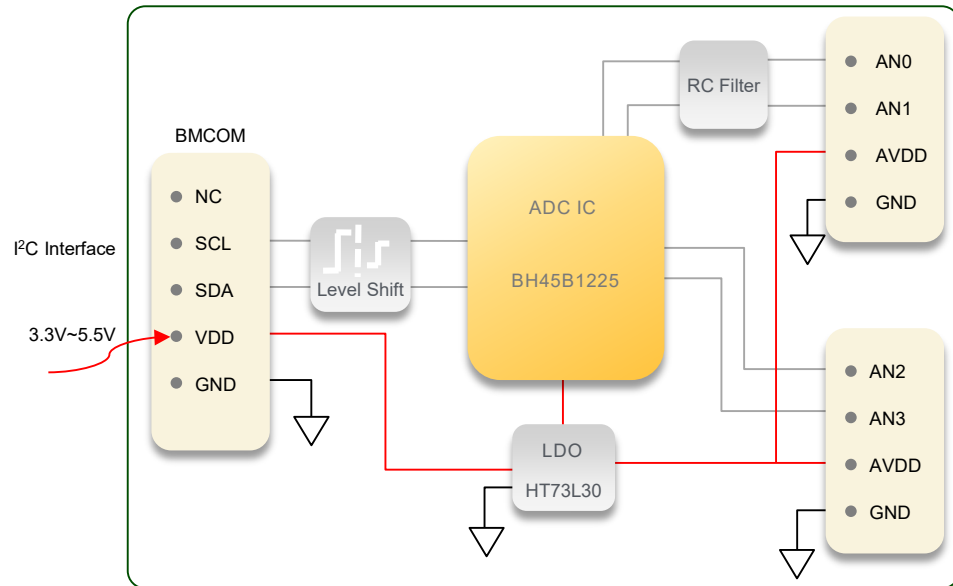

Pin Description

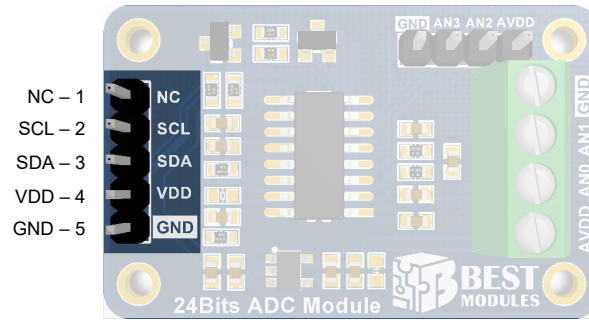

BMCOM Pin:

Pin	Function	Description
1	NC	Not connection
2	SCL	I ² C clock line
3	SDA	I ² C data line
4	VDD	Positive power supply
5	GND	Negative power supply, ground

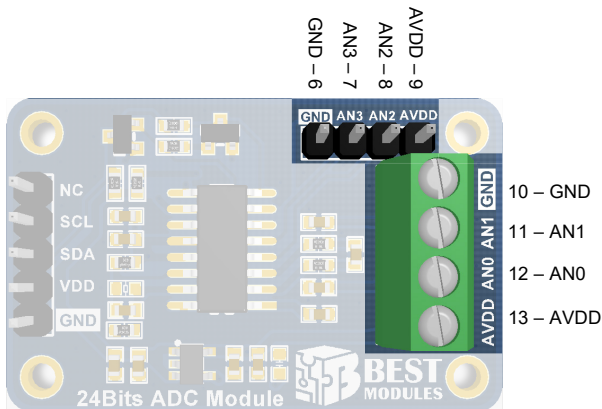

Analog Signal Input Interfaces:

Pin	Function	Operating Mode	Description
6	GND	Common signal input	Analog negative power supply, ground
7	AN3		A/D converter input channel 3
8	AN2		A/D converter input channel 2
9	AVDD		Analog positive power supply
10	GND	Wheatstone bridge input	Analog negative power supply, ground
11	AN1		A/D converter input channel 1
12	AN0		A/D converter input channel 0
13	AVDD		Analog positive power supply

Technical Specification

Recommended Operating Conditions

Ta=25°C

Symbol	Parameter	Condition	Min.	Typ.	Max.	Unit
V _{DD}	Module Operating Voltage	—	3.3	—	5.5	V
I _{DD}	Module Operating Current	V _{DD} =5.0V	—	1	—	mA
I _{STB}	Standby Current	V _{DD} =5.0V	—	—	1.5	µA
ENOB	Effective Number of Bits	V _{REF} =2.5V, Gain=32, Data rate=10Hz	—	20.7	—	Bit
		V _{REF} =2.5V, Gain=64, Data rate=10Hz	—	20.1	—	
		V _{REF} =2.5V, Gain=128, Data rate=10Hz	—	19.4	—	

Timing Specification

Ta=25°C

Symbol	Parameter	Condition	Min.	Typ.	Max.	Unit
t _{DEL-RSP}	Response Delay Time	V _{DD} =5.0V	1	—	—	ms
t _{INR}	Interval Time	V _{DD} =5.0V	1	—	—	ms

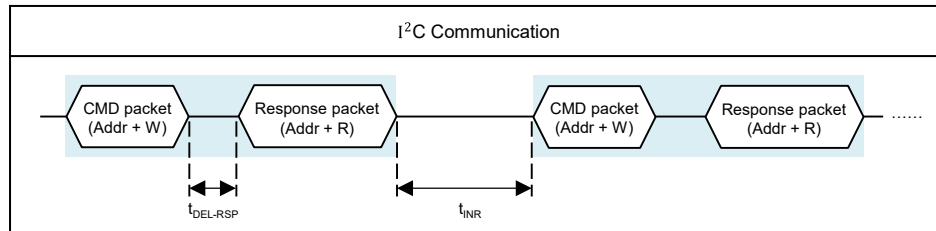

Hardware Overview

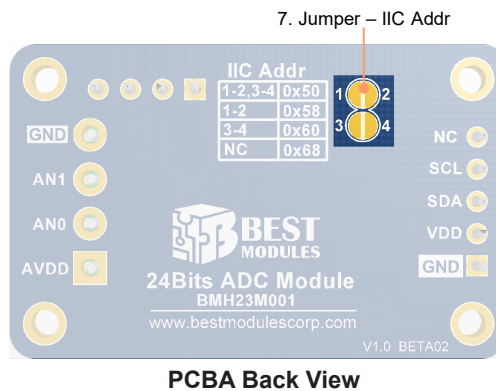
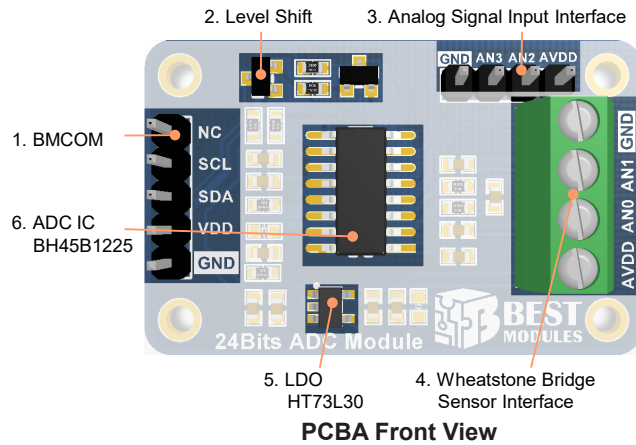

Power Supply

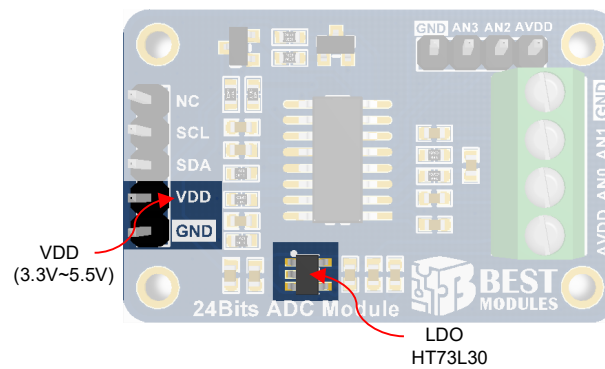

- BCOM Pin: Enter 3.3V~5.5V through VDD
- The module on-board LDO, the HT73L30, has the characteristics of low output noise, which makes the ADC measurement accuracy more accurate and stable.

Analog Signal Input Interface Selection

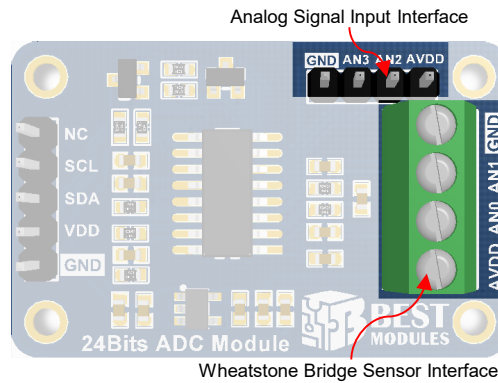

- Wheatstone bridge sensor interface: The corresponding channels are AN0 and AN1. Together with the load RC filter circuit, it has strong anti-interference ability and good low-frequency performance. The port is connected with a terminal connector. It is suitable for sensors based on Wheatstone bridge principle.
- Analog signal input interface: The corresponding channels are AN2 and AN3. The port is connected with a pin connector.

Communication Interface

- Communication mode: I²C
- I²C address selection: Default 0x68

I²C address format:

MSB							LSB
A6	A5	A4	A3	A2	A1	A0	R/W
1	1	0	1	0	0	0	

Slave address (0x68)

Note: R/W=1: Read
=0: Write

- I²C communication rate: ≤400kHz
- Communication logic reference voltage: 3.3V~5.5V
- The SCL/SDA pin of Module with 2.2kΩ pull-up resistor
- Communication protocol:
 - ◆ Refer to the BH45B1225 datasheet

Jumper

- I²C address selection:

I ² C Addr Jumper		I ² C Address
1-2	3-4	
Short circuit	Short circuit	0x50
Short circuit	Open circuit	0x58
Open circuit	Short circuit	0x60
Open circuit	Open circuit	0x68 (Factory default)

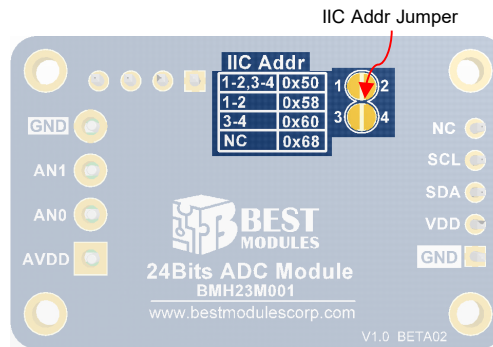

Application Circuits

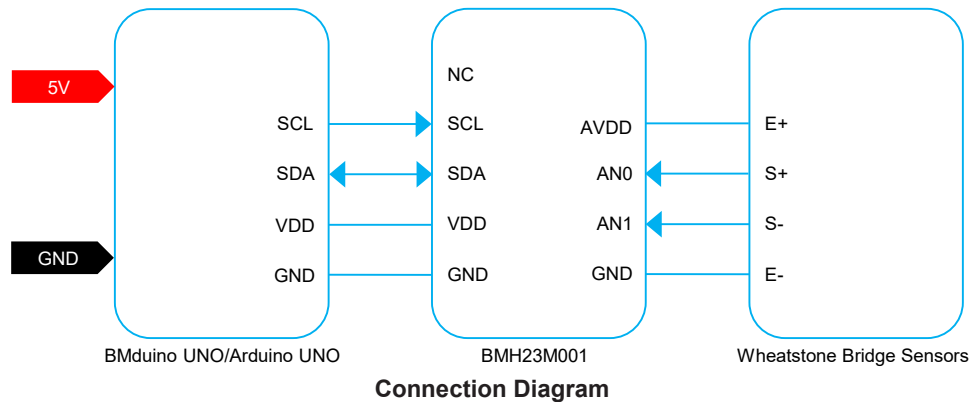

Dimensions

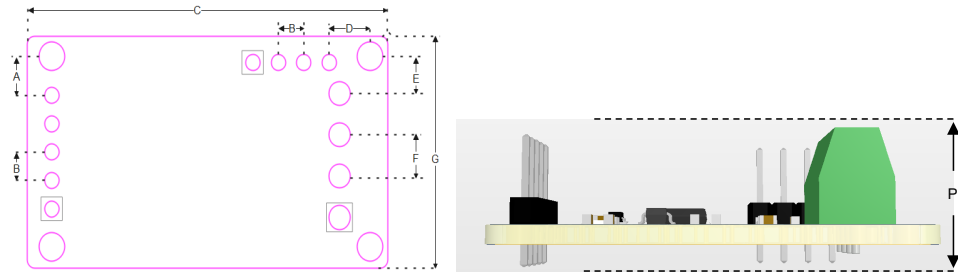

Dimension Information

Symbol \ Unit	mm	inch
A	4.57	0.18
B	2.54	0.1
C	39.0	1.54
D	4.22	0.17
E	4.40	0.17
F	3.50	0.14
G	24.6	0.97
P	12.2	0.48

Dimension List

Copyright© 2023 by BEST MODULES CORP. All Rights Reserved.

The information provided in this document has been produced with reasonable care and attention before publication, however, BEST MODULES does not guarantee that the information is completely accurate. The information contained in this publication is provided for reference only and may be superseded by updates. BEST MODULES disclaims any expressed, implied or statutory warranties, including but not limited to suitability for commercialization, satisfactory quality, specifications, characteristics, functions, fitness for a particular purpose, and non-infringement of any third-party's rights. BEST MODULES disclaims all liability arising from the information and its application. In addition, BEST MODULES does not recommend the use of BEST MODULES' products where there is a risk of personal hazard due to malfunction or other reasons. BEST MODULES hereby declares that it does not authorize the use of these products in life-saving, life-sustaining or safety critical components. Any use of BEST MODULES' products in life-saving/sustaining or safety applications is entirely at the buyer's risk, and the buyer agrees to defend, indemnify and hold BEST MODULES harmless from any damages, claims, suits, or expenses resulting from such use. The information provided in this document, including but not limited to the content, data, examples, materials, graphs, and trademarks, is the intellectual property of BEST MODULES (and its licensors, where applicable) and is protected by copyright law and other intellectual property laws. No license, express or implied, to any intellectual property right, is granted by BEST MODULES herein. BEST MODULES reserves the right to revise the information described in the document at any time without prior notice. For the latest information, please contact us.