



Microporous Atomiser Module

BM52D5021-1

Revision: V1.00 Date: September 27, 2023

www.bestmodulescorp.com

Table of Contents

Features	3
General Description	3
Applications	3
Selection Table	3
Block Diagram	3
Pin Assignment	4
Pin Description	4
Technical Specifications	4
Absolute Maximum Ratings	4
Recommended Operating Conditions	4
D.C. Electrical Characteristics.....	5
A.C. Electrical Characteristics.....	5
Functional Description	6
Functional Processes.....	6
Summary Table of Features	7
Power-on Reset	7
Interface	7
UART Interface.....	7
Application Circuits	8
Stand-alone Mode.....	8
UART Mode.....	8
Dimensions	9

Features

- Atomisation rate: 130ml/h – measured under the condition of good coordination with structures
- Power supply modes: Type-C interface / 2P socket 2.54mm
- Operating voltage: 5.0V±0.5V
- Operating current: 400mA±75mA
- Atomisation rated power: 2.0W
- Three-level adjustable power: 50% rated power, 75% rated power, 100% rated power
- Communication mode: UART communication – communication logic reference voltage: 3.3V/5V, baud rate: 9600

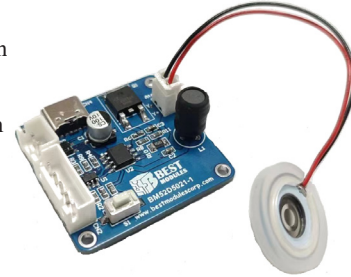

General Description

The BM52D5021-1 is a dedicated module for microporous atomisation plate, which is easy to operate and can be controlled using the UART serial interface. It provides three-level atomisation power adjustment as well as one-key for atomisation on/off, atomisation timing and other functions. The module provides a 4-pin bidirectional UART interface with a level shift function, which can be used for MCU communication in different voltages. It can be used with BMduino development boards, external host devices and other tools. These features make the module suitable for use in applications such as medical atomisers and beauty hydration devices.

Applications

- Beauty hydration devices
- Medical atomisers

Selection Table

Part No.	Output Frequency	Rated Power	Interface
BM52D5021-1	108kHz	2.0W	UART
BM52D5121-1	1.7MHz, 2.4MHz	5W~10W	UART

* Products are available from [Best Modules](https://www.bestmodules.com)

Block Diagram

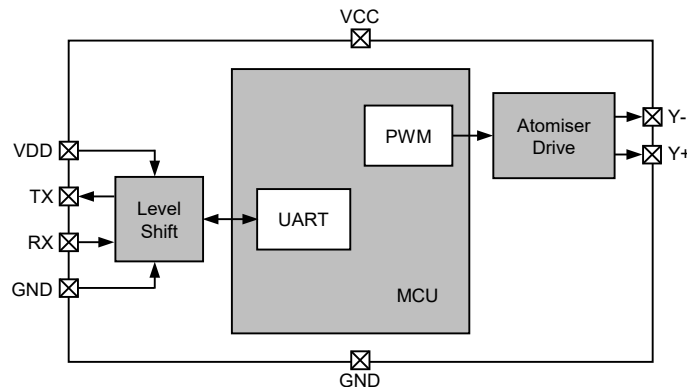

Functional Description

The module can output a 108kHz PWM square wave to drive the microporous atomisation plate. The atomisation function can be turned on by pressing a single key. The atomisation power and atomisation time can be controlled using the UART serial interface. These features assist users to develop their products quickly.

Functional Processes

After the system is powered on, the module is initialised. If no communication signal is received, the module will enter the stand-alone mode and start scanning the key. Pressing the key can turn on or off the atomisation function. If a communication signal is received, it will enter the communication mode to set the atomisation power, atomisation time and other functions.

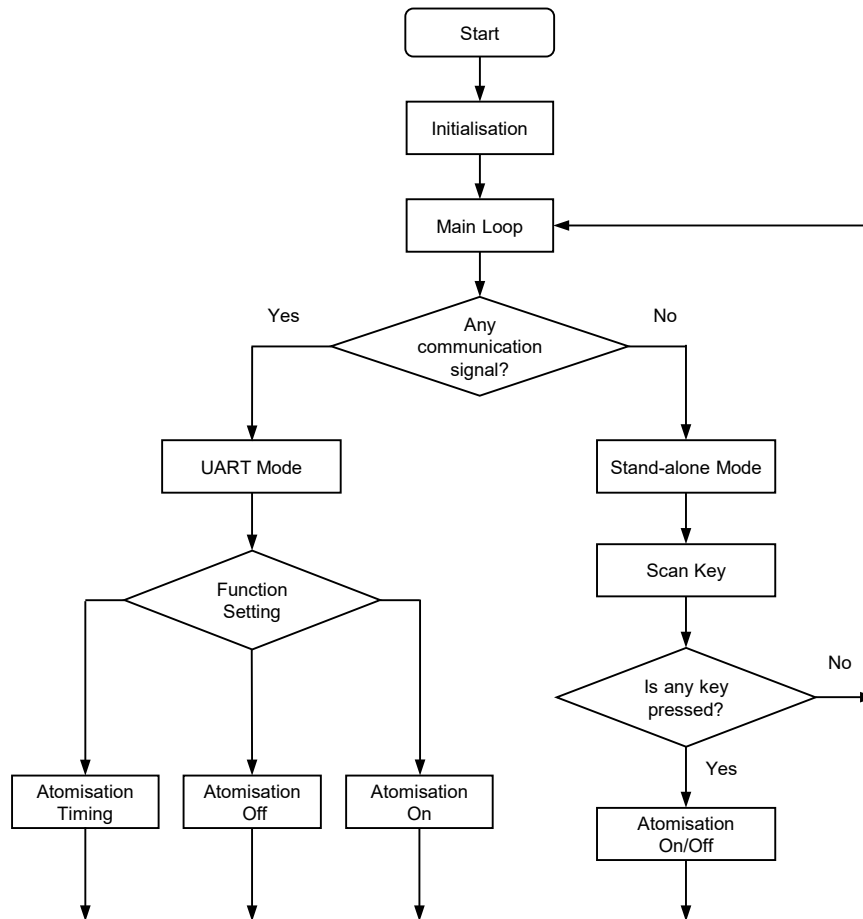

BM52D5021-1 Function Flowchart

Summary Table of Features

Function Support	Description
One-key for atomisation function on	Press the key to turn on or off the atomisation function according to the current operating state
Three-level power adjustment function	Adjust the output with different duty values. Level 1 power corresponds to 50% duty, Level 2 power corresponds to 75% duty and Level 3 power corresponds to 100% duty
Atomisation timing function	Control the atomisation duration time in minute. When the time is 0, it will retain on for up to 4.25 hours
Over current protection function	When the operating current is greater than 500mA, turn off atomisation

Power-on Reset

This reset occurs after power is first applied to the microcontroller. As well as ensuring that the Program Memory begins execution from the first memory address, a power-on reset also ensures that certain other registers are preset to known conditions. All the I/O port and port control registers will power up in a high condition ensuring that all pins will be first set to inputs.

Interface

The module supports the UART communication mode. In this mode, the host device can send commands to the module for its mode function control. For more details regarding the communication mode, refer to the UART section.

In the UART mode, the module atomisation time, atomisation on and off functions can be set.

UART Interface

UART Protocol

- UART communication baud rate: 9600
- Data bit: 8 bits, stop bit: 1 bit, parity bit: no
- Communication frame format:
 - ♦ Host sending

Frame Head (Head)	Module Type (MOD)	Data Length (LEN)	Command (CMD)	Data (D1, D2)	Checksum
1-byte	2-byte	1-byte	1-byte	2-byte	1-byte

- ♦ Module return

Frame Head (Head)	Module Type (MOD)	Data Length (LEN)	Command (CMD)	Data (D1, D2)	Checksum
1-byte	2-byte	1-byte	1-byte	2-byte	1-byte

Description:

The frame header is fixed as 0x55. The module type is fixed as (0x31, 0x01). The LEN value is the length of command code + data (Dn). The checksum starts from the frame header and takes the lowest 8 bits of the sum of all data. The module return value is consistent with the data sent by the host.

The UART protocol is as follows:

1. Byte 0: 0x55 – Fixed value
2. Byte 1: 0x31 – Module type
3. Byte 2: 0x01 – Module type

4. Byte 3: 0x03 – Number of data bytes
5. Byte 4: CMD – Command data, valid values: 0x00, 0x01, 0x02
6. Byte 5: TIME – Atomisation operating time, range: 0x00~0xff
7. Byte 6: PWR – Atomisation power level, range: 0x01~0x03
8. Byte 7: CS – Checksum, its value is the sum of Byte 0~6

No.	CMD	Function	Sent Data	Example (Hexadecimal)
1	0x02	Enable atomisation mode	Byte 5: 0x00 Byte 6: 0x00	Enable atomisation mode: 55 31 01 03 02 00 00 8C
2	0x01	Turn on atomisation function	Byte 5: TIME Byte 6: PWR When the atomisation mode is enabled, TIME is set as the atomisation duration time (range: 0x00~0xff, 0 indicates maintain atomising), and PWR is set as atomisation power/duty (range: 0x01 to 0x03. Other values have the same effect as the value 0x03, which indicates the maximum power/duty)	Turn on atomisation function: 55 31 01 03 01 01 03 8F This instruction indicates to turn on the atomisation function at Level 3 for 1 minute
3	0x00	Turn off atomisation function	Byte 5: Data Byte 6: Data (range: 0x00~0xff)	Turn off atomisation: 55 31 01 03 00 00 00 8A This instruction indicates to turn off the atomisation function

Note: Data can be any value ranging from 0 to 0xff. As long as the received instruction is verified correctly, the received instruction will be sent to the host as a feedback signal.

Application Circuits

Stand-alone Mode

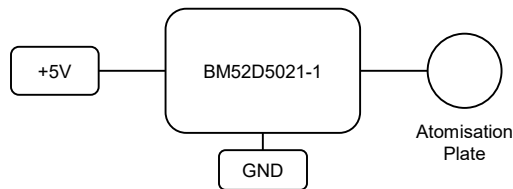

UART Mode

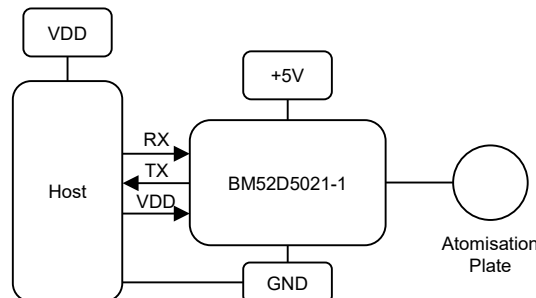

Dimensions

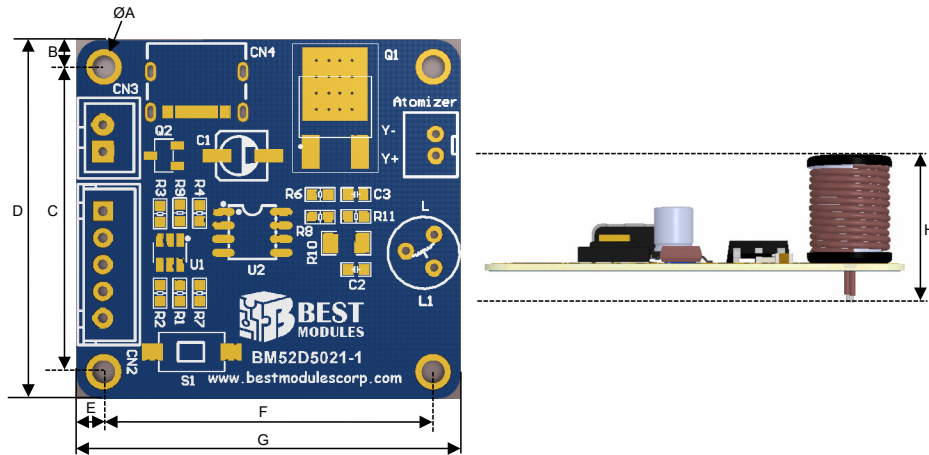

Symbol	Unit	
	mm	inch
ØA	2.20	0.0866
B	2.50	0.0984
C	28.5	1.1220
D	33.5	1.3189
E	2.50	0.0984
F	30.8	1.2126
G	35.8	1.4094
H	15.50	0.6102

Copyright© 2023 by BEST MODULES CORP. All Rights Reserved.

The information provided in this document has been produced with reasonable care and attention before publication, however, BEST MODULES does not guarantee that the information is completely accurate. The information contained in this publication is provided for reference only and may be superseded by updates. BEST MODULES disclaims any expressed, implied or statutory warranties, including but not limited to suitability for commercialization, satisfactory quality, specifications, characteristics, functions, fitness for a particular purpose, and non-infringement of any third-party's rights. BEST MODULES disclaims all liability arising from the information and its application. In addition, BEST MODULES does not recommend the use of BEST MODULES' products where there is a risk of personal hazard due to malfunction or other reasons. BEST MODULES hereby declares that it does not authorise the use of these products in life-saving, life-sustaining or safety critical components. Any use of BEST MODULES' products in life-saving/sustaining or safety applications is entirely at the buyer's risk, and the buyer agrees to defend, indemnify and hold BEST MODULES harmless from any damages, claims, suits, or expenses resulting from such use. The information provided in this document, including but not limited to the content, data, examples, materials, graphs, and trademarks, is the intellectual property of BEST MODULES (and its licensors, where applicable) and is protected by copyright law and other intellectual property laws. No license, express or implied, to any intellectual property right, is granted by BEST MODULES herein. BEST MODULES reserves the right to revise the information described in the document at any time without prior notice. For the latest information, please contact us.